

XP70

Plural-Component Sprayer

3A0420K

EN

Complete mechanical fixed ratio plural-component sprayer used for proportioning, mixing, and spraying two component quick setting materials. For professional use only.



Important Safety Instructions

Read all warnings and instructions in this manual. Save these instructions.

See page 11 for maximum working pressure and model information.

Patents Pending

XP70 Sprayer shown with hoppers and optional solvent flush pump and heaters.

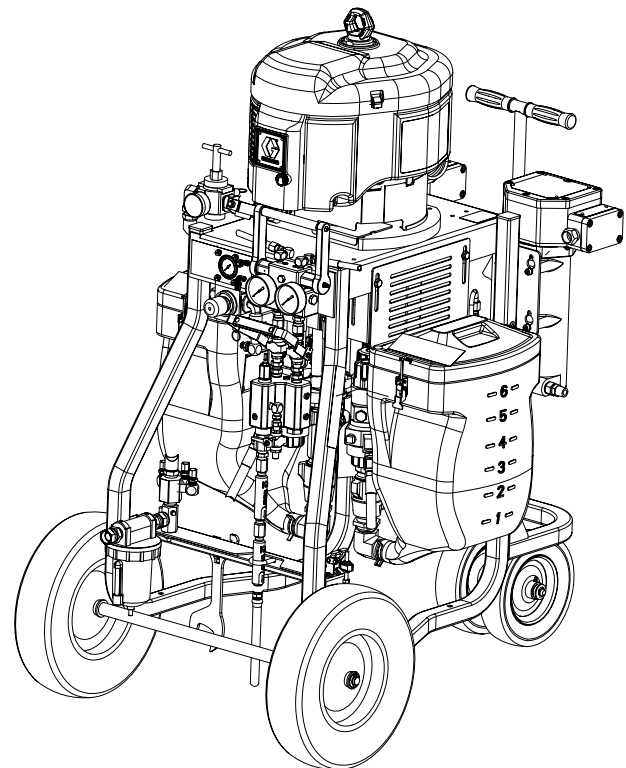

r_571100_3A0420A_1a-2



Contents

Related Manuals	3	Flush Mixed Material	26
Warnings	4	Flush Mix Manifold, Hose, and Spray Gun	26
Important Two-Component Material Information .	7	Empty and Flush Entire System	
Isocyanate Conditions	7	(new sprayer or end of job)	27
Material Self-ignition	7	Shutdown	28
Keep Components A and B Separate	7	Park	28
Moisture Sensitivity of Isocyanates	7	System Verification	29
Foam Resins with 245 fa Blowing Agents	7	Maintenance	30
Changing Materials	8	Filters	30
A and B Component Designations	8	Seals	30
Overview	9	Cleaning Procedure	30
Usage	9	Recommended Spare Parts	30
Over Pressure Protection	9	Change the Mix Ratio	30
Initial System Setup	10	Troubleshooting	31
Models	11	Pump Troubleshooting	32
Cart-Mounted XP70 Sprayers	11	Repair	33
Bare Proportioning Pump Packages	11	Pump Assembly	33
Component Identification	12	Air Controls	34
Fluid Control Assembly	13	Mix Manifold Assembly	36
Main Air Controls	13	Fluid Circulation Manifold	36
45:1 Solvent Flush Pump Kit 262393 (optional)	14	Hoppers	38
Air Line	15	Solvent Pump	38
Fluid Line Accessories	15	Optional Fluid Heaters	39
Flush Before Using Equipment	15	Parts	40
Setup	16	Cart-Mounted XP70 Sprayer	40
Location	16	Bare Proportioning Pump Package	44
Grounding	16	Air Controls, 258983	46
Wire Sprayers with Explosion-Proof Heaters . .	17	Fluid Manifold, 258990	47
Air Motor Position	18	Recommended Spare Parts	48
Connect Air Supply	19	Pump Performance Charts	49
Connect Static Mixers, Gun, and Hoses	19	Calculate Fluid Outlet Pressure	49
Connect Fluid Hose Bundles (Remote Only) . .	19	Calculate Pump Air Flow/Consumption	49
Pressure Relief Procedure	20	Accessories and Kits	52
Prime Empty Sprayer	21	Acceptable For Use in Explosive Atmospheres .	52
Prime A and B Fluids	21	Not Approved For Explosive Atmospheres	52
Prime Solvent Flush Pump	22	Technical Data	53
Recirculate or Re-Prime After a Pump Runs Dry	23	Dimensions	54
Spray	24	Bare Proportioner Mounting Hole Dimensions .	55
B Side Mix Manifold Restriction	25	Graco Standard Warranty	56

Related Manuals





Manuals are available at www.graco.com

Component Manuals in English:

Manual	Description
311762	Xtreme® Displacement Pumps Instructions-Parts
311238	NXT® Air Motor Instructions-Parts
3A0590	Mix Manifold Instructions-Parts
312747	20 Gallon Double Wall Hopper Kit Instructions-Parts
309524	Viscon® HP Heater Instructions-Parts
312145	XTR™ 5 and XTR™ 7 Spray Guns Instructions-Parts
312769	Feed Pump and Agitator Kits Instructions-Parts
312794	Merkur® Pump Assembly Instructions-Parts
310863	Feed and Solvent Flush Kits
406860	7-Gallon Hopper Installation Kit Instructions-Parts
406739	Desiccant Kit Instructions-Parts
309852	Polyurethane Circulation and Return Tube Kits, Instructions-Parts
406861	Viscon HP Heater Adapter Kit, Instruc- tions-Parts
3A0421	Ratio Check Kit, Instructions-Parts
309525	Heated Hose Kit, Instructions-Parts
309964	Gun Splitter Valve with Independent Flush, Instructions-Parts
339361	High Pressure Hose and Accessories Brochure
311486	DataTrak™ Conversion Kit, Instruc- tions-Parts

Warnings

The following warnings are for the setup, use, grounding, maintenance, and repair of this equipment. The exclamation point symbol alerts you to a general warning and the hazard symbols refer to procedure-specific risks. When these symbols appear in the body of this manual, refer back to these Warnings. Product-specific hazard symbols and warnings not covered in this section may appear throughout the body of this manual where applicable.

 WARNING	
	<p>FIRE AND EXPLOSION HAZARD</p> <p>Flammable fumes, such as solvent and paint fumes, in work area can ignite or explode. To help prevent fire and explosion:</p> <ul style="list-style-type: none"> • Use equipment only in well ventilated area. • Eliminate all ignition sources; such as pilot lights, cigarettes, portable electric lamps, and plastic drop cloths (potential static arc). • Keep work area free of debris, including solvent, rags and gasoline. • Do not plug or unplug power cords, or turn power or light switches on or off when flammable fumes are present. • Ground all equipment in the work area. See Grounding instructions. • Use only grounded hoses. • Hold gun firmly to side of grounded pail when triggering into pail. • If there is static sparking or you feel a shock, stop operation immediately. Do not use equipment until you identify and correct the problem. • Keep a working fire extinguisher in the work area.
	<p>SPECIAL CONDITIONS FOR SAFE USE</p> <ul style="list-style-type: none"> • To prevent the risk of electrostatic sparking, the equipment's non-metallic parts must be cleaned with only a damp cloth. • Refer to the Viscon HP Heater manual for special conditions for safe use.
	<p>ELECTRIC SHOCK HAZARD</p> <p>This equipment must be grounded. Improper grounding, setup, or usage of the system can cause electric shock.</p> <ul style="list-style-type: none"> • Turn off and disconnect power at main switch before disconnecting any cables and before servicing equipment. • Connect only to grounded power source. • All electrical wiring must be done by a qualified electrician and comply with all local codes and regulations.

WARNING



SKIN INJECTION HAZARD

High-pressure fluid from gun, hose leaks, or ruptured components will pierce skin. This may look like just a cut, but it is a serious injury that can result in amputation. **Get immediate surgical treatment.**

- Do not spray without tip guard and trigger guard installed.
- Engage trigger lock when not spraying.
- Do not point gun at anyone or at any part of the body.
- Do not put your hand over the spray tip.
- Do not stop or deflect leaks with your hand, body, glove, or rag.
- Follow the **Pressure Relief Procedure** when you stop spraying and before cleaning, checking, or servicing equipment.
- Tighten all fluid connections before operating the equipment.
- Check hoses and couplings daily. Replace worn or damaged parts immediately.



EQUIPMENT MISUSE HAZARD

Misuse can cause death or serious injury.

- Do not operate the unit when fatigued or under the influence of drugs or alcohol.
- Do not exceed the maximum working pressure or temperature rating of the lowest rated system component. See **Technical Data** in all equipment manuals.
- Use fluids and solvents that are compatible with equipment wetted parts. See **Technical Data** in all equipment manuals. Read fluid and solvent manufacturer's warnings. For complete information about your material, request MSDS from distributor or retailer.
- Do not leave the work area while equipment is energized or under pressure. Turn off all equipment and follow the **Pressure Relief Procedure** when equipment is not in use.
- Check equipment daily. Repair or replace worn or damaged parts immediately with genuine manufacturer's replacement parts only.
- Do not alter or modify equipment.
- Use equipment only for its intended purpose. Call your distributor for information.
- Route hoses and cables away from traffic areas, sharp edges, moving parts, and hot surfaces.
- Do not kink or over bend hoses or use hoses to pull equipment.
- Keep children and animals away from work area.
- Comply with all applicable safety regulations.



MOVING PARTS HAZARD

Moving parts can pinch, cut or amputate fingers and other body parts.

- Keep clear of moving parts.
- Do not operate equipment with protective guards or covers removed.
- Pressurized equipment can start without warning. Before checking, moving, or servicing equipment, follow the **Pressure Relief Procedure** and disconnect all power sources.

WARNING



TOXIC FLUID OR FUMES HAZARD

Toxic fluids or fumes can cause serious injury or death if splashed in the eyes or on skin, inhaled, or swallowed.

- Read MSDSs to know the specific hazards of the fluids you are using.
- Store hazardous fluid in approved containers, and dispose of it according to applicable guidelines.
- Always wear chemically impermeable gloves when spraying, dispensing, or cleaning equipment.



PERSONAL PROTECTIVE EQUIPMENT

You must wear appropriate protective equipment when operating, servicing, or when in the operating area of the equipment to help protect you from serious injury, including eye injury, hearing loss, inhalation of toxic fumes, and burns. This equipment includes but is not limited to:

- Protective eyewear, and hearing protection.
- Respirators, protective clothing, and gloves as recommended by the fluid and solvent manufacturer.







BURN HAZARD

Equipment surfaces and fluid that's heated can become very hot during operation. To avoid severe burns:



- Do not touch hot fluid or equipment.

Important Two-Component Material Information



Isocyanate Conditions

						
<p>Spraying or dispensing materials containing isocyanates creates potentially harmful mists, vapors, and atomized particulates.</p> <p>Read material manufacturer's warnings and material MSDS to know specific hazards and precautions related to isocyanates.</p> <p>Prevent inhalation of isocyanate mists, vapors, and atomized particulates by providing sufficient ventilation in the work area. If sufficient ventilation is not available, a supplied-air respirator is required for everyone in the work area.</p> <p>To prevent contact with isocyanates, appropriate personal protective equipment, including chemically impermeable gloves, boots, aprons, and goggles, is also required for everyone in the work area.</p>						

Material Self-ignition

						
<p>Some materials may become self-igniting if applied too thick. Read material manufacturer's warnings and material MSDS.</p>						

Keep Components A and B Separate

						
<p>Cross-contamination can result in cured material in fluid lines which could cause serious injury or damage equipment. To prevent cross-contamination of the equipment's wetted parts, never interchange component A (isocyanate) and component B (resin) parts.</p>						

Moisture Sensitivity of Isocyanates

Isocyanates (ISO) are catalysts used in two component foam and polyurea coatings. ISO will react with moisture (such as humidity) to form small, hard, abrasive crystals, which become suspended in the fluid. Eventually a film will form on the surface and the ISO will begin to gel, increasing in viscosity. If used, this partially cured ISO will reduce performance and the life of all wetted parts.

NOTE: The amount of film formation and rate of crystallization varies depending on the blend of ISO, the humidity, and the temperature.

To prevent exposing ISO to moisture:

- Always use a sealed container with a desiccant dryer in the vent, or a nitrogen atmosphere. **Never** store ISO in an open container.
- Keep the ISO pump wetcup or reservoir (if installed) filled with Graco Throat Seal Liquid (TSL™), Part 206995. The lubricant creates a barrier between the ISO and the atmosphere.
- Use moisture-proof hoses specifically designed for ISO.
- Never use reclaimed solvents, which may contain moisture. Always keep solvent containers closed when not in use.
- Never use solvent on one side if it has been contaminated from the other side.
- Always lubricate threaded parts with TSL or grease when reassembling.

Foam Resins with 245 fa Blowing Agents

Some foam blowing agents will froth at temperatures above 90°F (33°C) when not under pressure, especially if agitated. To reduce frothing, minimize preheating in a circulation system.

Changing Materials

- Changing material types used in your sprayer requires special attention to avoid equipment damage and downtime.
- Always clean the fluid inlet strainers after flushing.
- When changing between epoxies and urethanes or polyureas, disassemble and clean all fluid components and changes hose sets.
- Check with your material manufacturer for chemical compatibility.
- Most materials use ISO on the A side, but some use ISO on the B side.
- Epoxies often have amines on the B (hardener) side. Polyureas often have amines on the B (resin) side.

A and B Component Designations

Material suppliers and markets refer to plural component materials differently. The table below summarizes the different designations for the components used in various machines.

Market	Equipment	Designations	Machine Left Side	Machine Right Side
Foam and Polyurea, and Urethane Pour	All Reactors, HFR™, and VRM™	Letter	A	B
		Color	Red	Blue
		Component Names	ISO, Hardener, Catalyst	Polyol, Resin, Base
		Major or Minor Component (when not 1:1 mix)	Low Volume Side	High Volume Side
Epoxy and Urethane Protective Coatings	Hydra-Cat®, Xtreme-Mix™, XM™, and XP70	Letter	A	B
		Color	Blue	Green
		Component Names	Resin, Base	Hardener, Catalyst
		Major or Minor Component (when not 1:1 mix)	High Volume Side	Low Volume Side
Epoxy, Silicone, Urethanes, and other materials	PR70™ and PR	Letter	A	B
		Color	Red	Blue
		Component Names	Polyol, Resin, Base	ISO, Hardener, Catalyst
		Major or Minor Component (when not 1:1 mix)	High Volume Side	Low Volume Side

Overview

Usage

The XP70 plural-component sprayer is a mechanical fixed ratio sprayer that can mix and spray most two-component epoxy and urethane protective coatings. When using quick-setting material (less than 10 minute pot life) a remote mix manifold must be used.

The two pumps are carbide seat severe duty positive displacement pumps that displace fluid on both strokes simultaneously on ratio to one another.



XP70 sprayers are not approved for use in hazardous locations unless the base model, all accessories, all kits, and all wiring meet local, state, and national codes. See **Important Two-Component Material Information**, page 7, to determine the appropriate location for your particular sprayer model.

Over Pressure Protection



Mechanically linked pumps can create excessive fluid pressure if the full motor force is applied to only one of the fluid pumps.

- Maximum air pressure set point blow off valves are provided to limit maximum fluid pressure. Do not remove these valves.
- Automatic pressure relief valves are used to dump excess pressure back to the supply. Never plug these return hoses.
- Common handles link the fluid control valves. Never install individual shut off valves on the “A” and “B” lines.
- On models other than 1:1 mix ratio, a rupture disc is provided on the small side fluid pump as a back-up to the over pressure relief valve. If the rupture disc ever opens, do not operate the machine until the over pressure valve and the rupture disc have been replaced.

Initial System Setup



Complete the following steps in the order they are listed, as they apply to your specific system, for initial system setup.

1. Check the shipment for accuracy. Ensure you have received everything you ordered. See **Component Identification**, page 12.
2. Check for loose fittings and fasteners.
3. Install optional solvent flush pump kit 262393, if ordered. See manual 310863 for instructions.
4. Mount and connect optional heaters, if ordered. See the heater adapter kit manual 406861 for instructions and the heater manual 309524.
5. Install desiccant kits, if using polyurethane isocyanates in hoppers. See manual 406739 for instructions.
6. Install circulation and return tube kits if you are feeding material from drums. See manual 309852 if you are feeding urethane material.

NOTE: Supply return lines must be used.

7. Connect the feed pumps, fluid strainers, and air hoses as necessary. If your sprayer does not use hoppers, then see manual 312769.
8. Connect the air supply line. See **Connect Air Supply**, page 19.
9. Connect the fluid hose assembly, including the static mixers, whip hose and gun. See **Pressure Relief Procedure**, page 20.
10. Flush test oil from system as needed. See **Empty and Flush Entire System (new sprayer or end of job)**, page 27.

Models

						
XP70 sprayers are approved for use in hazardous locations only if the base model, all accessories, all kits, and all wiring meet local, state, and national codes.						

Cart-Mounted XP70 Sprayers

All XP70 sprayers include static mixers, 3/8 x 25 ft hose, clean up mixer, 1/4 x 10 ft (x m) whip hose, and XTR 7 spray gun with a 519 tip. See **Accessories and Kits** on page 52 for a list of all optional accessories.

Sprayer	Volume Mix Ratio	Pump Package	7 Gallon Hoppers	Maximum Fluid Working Pressure psi (MPa, bar)	Maximum Air Working Pressure psi (MPa, bar)	Fluid/Air Pressure Ratio
571101	1:1	571100		7250 (50, 500)	95 (0.6, 6.5)	76:1
571102	1:1	571100	✓	7250 (50, 500)	95 (0.6, 6.5)	
571151	1.5:1	571150		7250 (50, 500)	80 (0.5, 5.5)	91:1
571152	1.5:1	571150	✓	7250 (50, 500)	80 (0.5, 5.5)	
571201	2:1	571200		7250 (50, 500)	95 (0.6, 6.5)	76:1
571202	2:1	571200	✓	7250 (50, 500)	95 (0.6, 6.5)	
571251	2.5:1	571250		6500 (45, 448)	100 (0.7, 7)	65:1
571252	2.5:1	571250	✓	6500 (45, 448)	100 (0.7, 7)	
571301	3:1	571300		6800 (47, 469)	100 (0.7, 7)	68:1
571302	3:1	571300	✓	6800 (47, 469)	100 (0.7, 7)	
571401	4:1	571400		7250 (50, 500)	100 (0.7, 7)	73:1
571402	4:1	571400	✓	7250 (50, 500)	100 (0.7, 7)	

Bare Proportioning Pump Packages

All pump packages use a NXT Air Motor N65DN0.

Pump Package	A Side Pump	B Side Pump	Volume Mix Ratio	Combined Fluid Output cc/cycle	NXT6500 Fluid/Air Ratio:1	Fluid Flow at 40 cpm gpm (lpm)	Maximum Fluid Working Pressure psi (MPa, bar)	Maximum Air Working Pressure psi (MPa, bar)
571100	L085C0	L085C0	1:1	173	76	1.8 (6.8)	7250 (50, 500)	95 (0.6, 6.5)
571150	L085C0	L058C0	1.5:1	144	91	1.5 (5.6)	7250 (50, 500)	80 (0.5, 5.5)
571200	L115C0	L058C0	2:1	174	76	1.8 (6.8)	7250 (50, 500)	95 (0.6, 6.5)
571250	L14AC0	L058C0	2.5:1	203	65	2.1 (7.9)	6500 (45, 448)	100 (0.7, 7)
571300	L14AC0	L048C0	3:1	193	68	2.0 (7.5)	6500 (45, 448)	100 (0.7, 7)
571400	L14AC0	L036C0	4:1	181	73	1.9 (7.1)	7250 (50, 500)	100 (0.7, 7)

The pump size is marked on the pump cylinders.

Component Identification

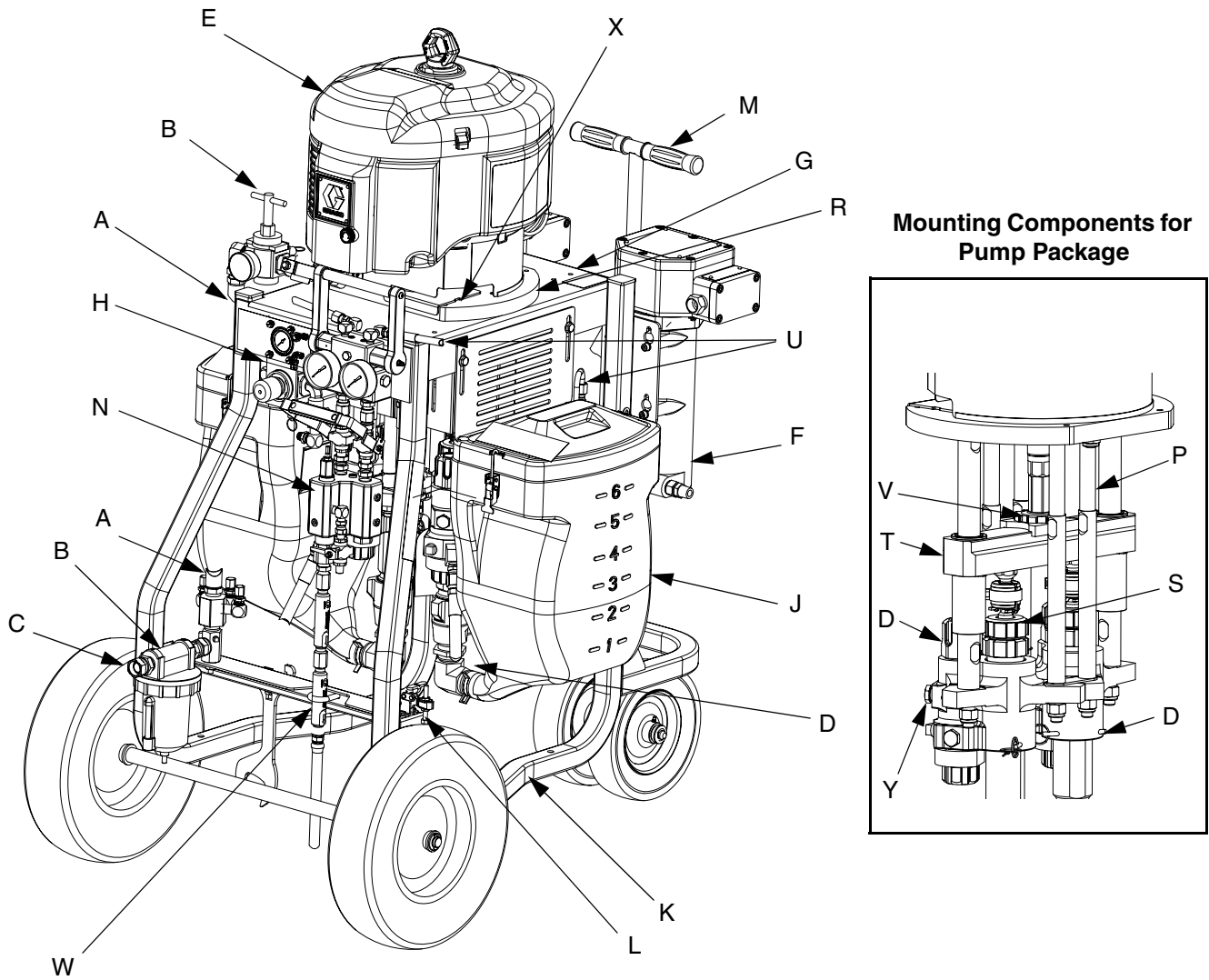

r_571101_3a0420a_1a-2

FIG. 1: XP70 Sprayer with optional accessories

Key:

- | | |
|---|--|
| A Air Motor Supply Hose | N Fluid Control Assembly; <i>see page 13</i> |
| B Main Air Controls; <i>see page 13</i> | P Tie Rods |
| C Air Inlet - 3/4 Npsm(F) | R Motor Adapter Plate |
| D High Pressure Fluid Pump | S Adjustable Packing Nuts with Wet Cups |
| E Air Motor | T Yoke With Rod Bearings |
| F Fluid Heater (optional) | U Recirculation Lines |
| G Solvent Flush Pump (optional); <i>see page 14</i> | V Yoke Position Nut |
| H Solvent Flush Pump Air Controls; <i>see page 14</i> | W Static Mixer Tubes with Replacement Plastic Elements |
| J 7 Gallon Hoppers (optional) | X Motor Position Indicator |
| K Cart | Y Over Pressure Rupture Disc;
only 38cc, 48cc, and 58cc pumps |
| L Brake | |
| M Handle (lift to release) | |

Fluid Control Assembly

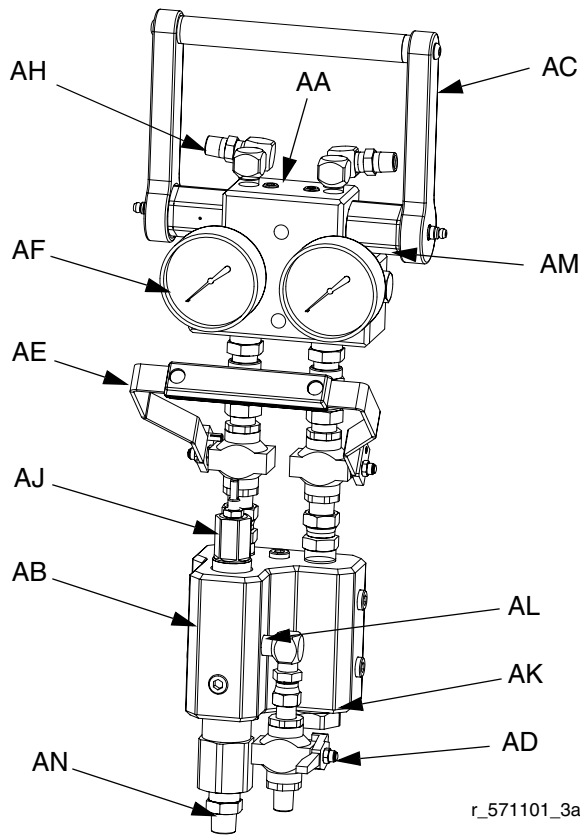

Key:

- AA Fluid Manifold
- AB Mix Manifold
- AC Circulation Handle
- AD Solvent Flush Valve
- AE Dual Shutoff Handle
- AF Fluid Pressure Gauges
- AG Fluid Supply Inlet (Behind Fluid Manifold)
- AH Fluid Circulation Fittings
- AJ B Component Adjustable Fluid Restrictor
- AK A and B Mix Manifold Check Valves
- AL Solvent Inlet Check Valve
- AM Automatic Over-Pressure Relief Valves; with grease fittings
- AN A and B Combined Outlet; 3/8 npt(m)

r_571101_3a0420a_3a-2

FIG. 2

Main Air Controls

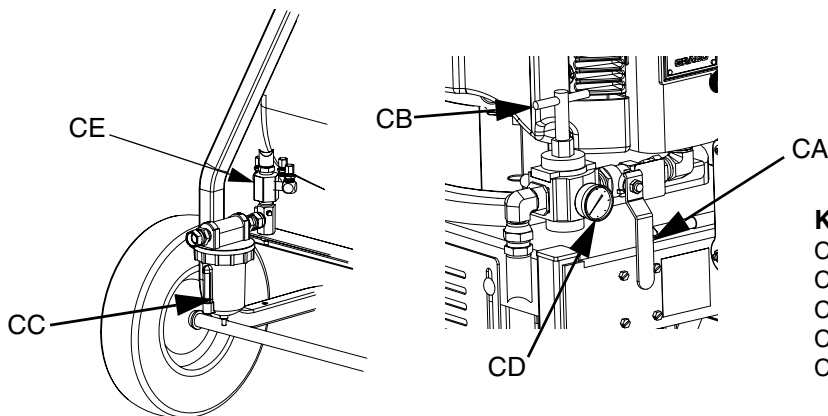

Key:

- CA Main Air Motor Shutoff Valve (Relieving)
- CB Main Motor Pressure Regulator
- CC Air Filter with Auto Drain
- CD Main Pump Air Regulator Gauge
- CE Filtered Air Distribution Manifold

FIG. 3

45:1 Solvent Flush Pump Kit 262393 (optional)

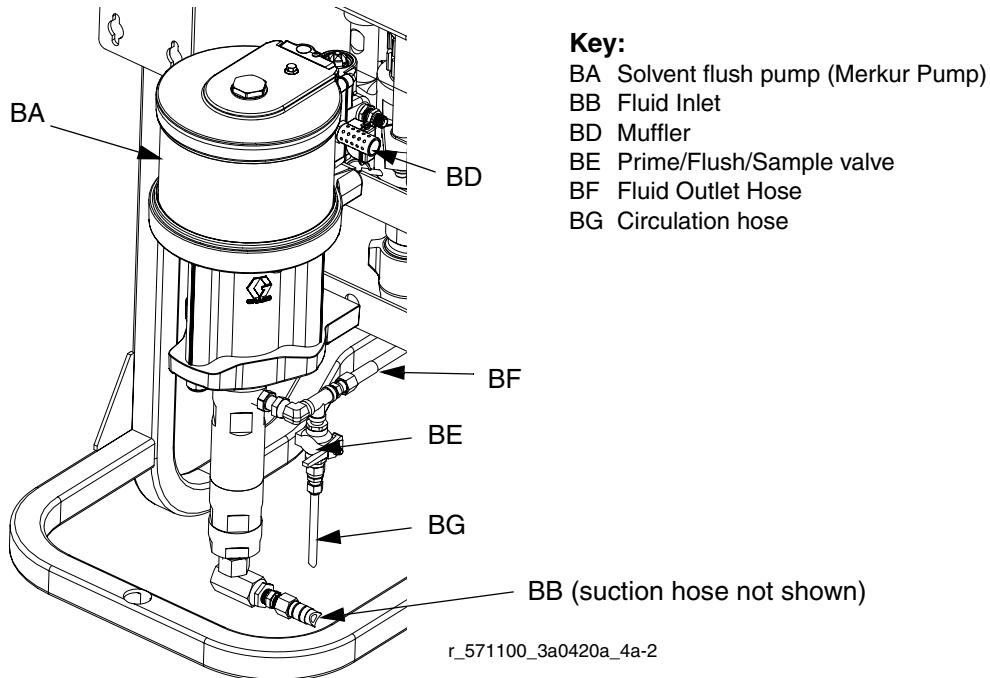

FIG. 4: Solvent Flush Pump Kit

Air Controls

Included with optional solvent flush pump kit 262393.

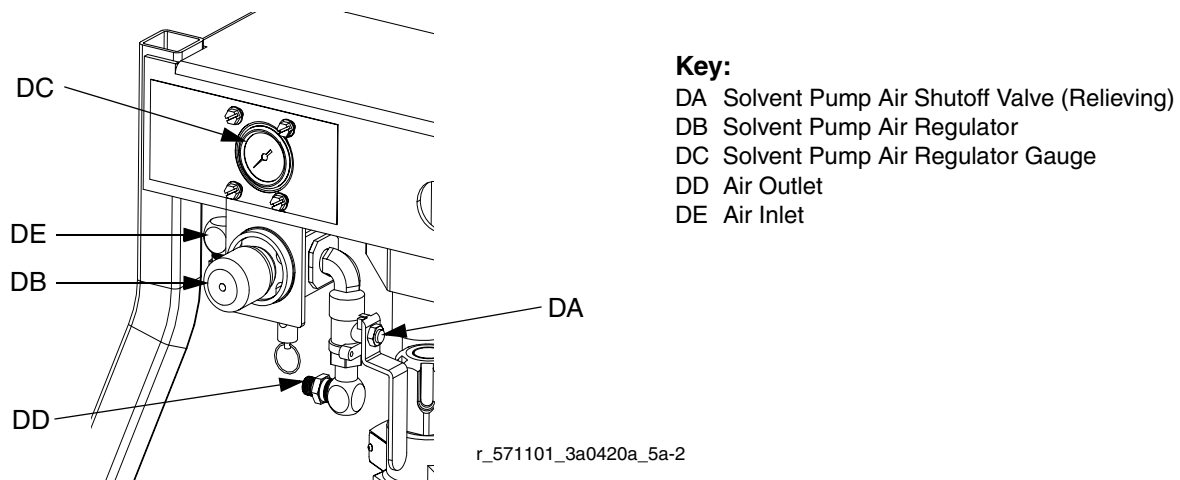
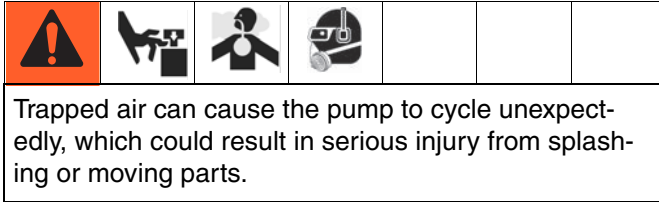

FIG. 5: Solvent Flush Pump Kit Air Controls

Air Line

Bleed-type master air valve (CA): required in your system to relieve air trapped between it and the air motor when the valve is closed.



- Be sure the valve is easily accessible from the pump and located downstream from the air regulator.
- **Pump air regulator (CB):** to control pump speed and outlet pressure.
- **Air line filter (C):** 40 micron filter that removes harmful dirt and moisture from compressed air supply. Accumulated water is automatically drained from the filter.

Fluid Line Accessories

- **Fluid Manifold (AA):** mounts fluid gauges and over pressure relief valves. Controls circulation and pump priming.
- **Mix Manifold (AB):** brings A and B fluid together. Provides control and check valves for A, B, and flush fluids.
- **Circulation Handle (AC):** open to relieve fluid pressure, prime pumps, and circulate material in hoppers. Close to spray mixed material.
- **Dual Shutoff Handle (AE):** Controls A and B on/off flow into mix manifold. Press down to provide A and B fluid to the mix manifold and into the static mixer for spraying. Press up to turn off A and B before flushing the mixed material.
- **Solvent Flush Valve (AD):** to flush solvent through mix manifold, hose, and spray gun.
- **Static mixer/gun hose kit:** to mix the two fluids and deliver mix to the spray gun. Includes static mixer and hoses to the spray gun.

Optional Accessories



- **Optional Fluid Heaters (N):** to heat the resin and hardener before mixing. Improves the chemical reaction and lowers viscosity to improve the spray pattern.
- **Optional Solvent Flush Kit (G):** to flush the mix manifold. Includes a solvent pump, mounting hardware, and solvent supply hose.

Flush Before Using Equipment

The equipment was tested with lightweight oil, which is left in the fluid passages to protect parts. To avoid contaminating your fluid with oil, flush the equipment with a compatible solvent before using the equipment. See **Empty and Flush Entire System (new sprayer or end of job)**, page 27.



Setup

Location

						
<p>XP70 sprayers are approved for use in hazardous locations only if the base model, all accessories, all kits, and all wiring meet local, state, and national codes.</p>						

1. Locate the proportioner on a level surface.
2. Position the proportioner for convenient operator access and maintenance, safe routing of air and fluid lines, and easy connection of components and accessories.
3. For permanent mounting, remove wheels and mount the frame to the floor. See **Dimensions**, page 54.
4. Ensure that the cart brake (L) is in the locked position.

Grounding

						
<p>The equipment must be grounded. Grounding reduces the risk of static and electric shock by providing an escape wire for the electrical current due to static build up.</p>						

Pump: use ground wire and clamp (supplied). Loosen grounding lug locknut (W) and washer (X). Insert ground wire end (Y) into lug (Z) slot and tighten locknut securely. Connect ground clamp to a true earth ground.

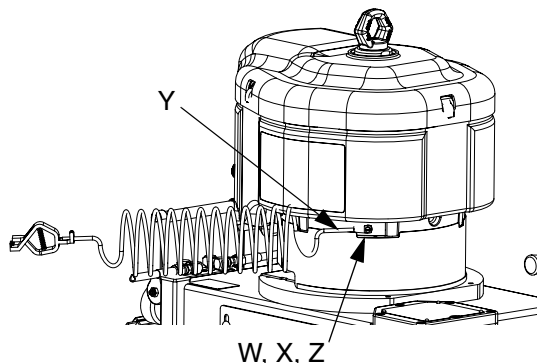

Solvent Pump: use ground wire and clamp (supplied with solvent pump). Follow instructions in pump manual.

Air and fluid hoses: use only static dissipation type hoses. with a maximum of 500 ft. (150 m) combined hose length to ensure grounding continuity. Check electrical resistance of hoses. If total resistance to ground exceeds 29 megohms, replace hose immediately.

Air compressor: follow manufacturer's recommendations.

Spray gun: ground through connection to a properly grounded fluid hose and pump.

Fluid supply container: follow local code.



Object being sprayed: follow local code.

Solvent pails used when flushing: follow local code. Use only conductive metal pails, placed on a grounded surface. Do not place the pail on a nonconductive surface, such as paper or cardboard, which interrupts grounding continuity.

To maintain grounding continuity when flushing or relieving pressure: hold metal part of the spray gun firmly to the side of a grounded metal pail, then trigger the gun.

Wire Sprayers with Explosion-Proof Heaters

(Hazardous location sprayers only)

						
<p>If your sprayer is rated for hazardous areas, and you have explosion-proof heaters, you must have a qualified electrician connect heater wiring. Ensure wiring and installation comply with local electrical codes for hazardous areas.</p>						

Improperly installed or connected equipment will create a hazardous condition and cause fire, explosion, or electric shock. Follow local regulations.

When explosion-proof heaters are used, ensure the wiring, wiring connections, switches, and electrical distribution panel all meet flame-proof (explosion-proof) requirements.

Refer to the Viscon HP heater manual for electrical connection instructions and guidelines in hazardous locations.

Air Motor Position

The air motor position must be set for the mix ratio of the machine, which is defined by which two pumps are mounted.

1. Verify that the correct pumps are mounted for your mix ratio by volume. See chart in **Bare Proportioning Pump Packages** on page 11.
2. Verify that the motor position is adjusted correctly for that mix ratio.

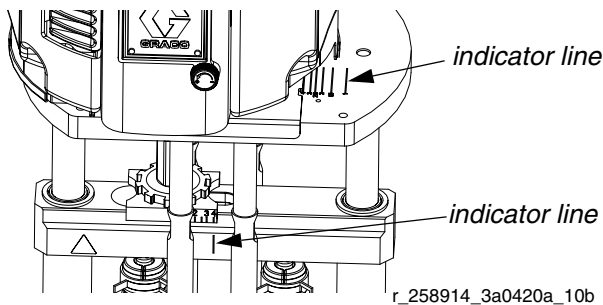
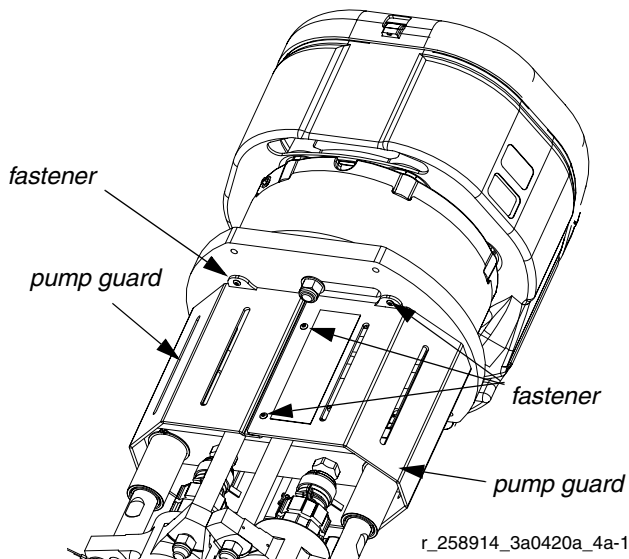

FIG. 6: Ratio indicators

Position Air Motor

There are specific positions for each fixed ratio setting. To adjust the position of the air motor:

1. Loosen the eight fasteners and remove the two pump guards.



2. Place wrench on adapter rod (104).
3. Use tool (70) to loosen the serrated yoke nut (V) above the yoke (T).

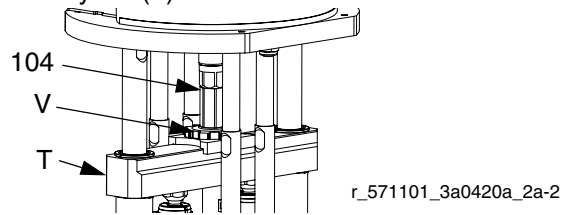

4. Loosen the three nuts (P2) below the motor tie rods.

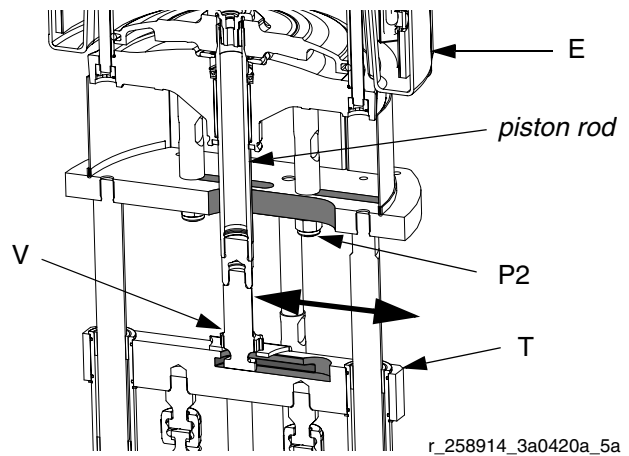

5. Grab the piston rod and slide the position of the motor (E) until the indicator lines are aligned with your ratio. See FIG. 6.

NOTICE

Do not hit tie rods (P) with a steel hammer. Damage to the air motor base may result.

6. Tighten the three nuts (P2) and yoke nut (V). Use tool (70) to tighten the yoke nut.
7. Install the pump guards.

Connect Air Supply

1. Connect the air supply hose to the 3/4 npt(f) air filter inlet (C).

NOTE: Use a 3/4 in. (19.1 mm) ID minimum air hose. Air consumption is 75 cfm per gallon per minute spraying. Do not use pin fitting type quick disconnects.

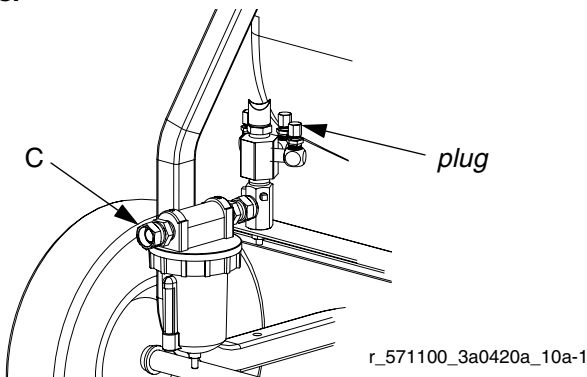

2. Remove plugs as necessary for solvent pump and feed supply pump air hoses. See pump manuals for setup instructions.

Connect Static Mixers, Gun, and Hoses

NOTICE

To prevent creating a flare on the mixer tube, do not use an union swivel end on the mix tube inlet.

1. Connect the outlet of the two primary static mixer tubes, with mixer elements (W), to the fluid mix hose (25), cleanup mixer (27, 28), whip hose (30), and spray gun (31). See FIG. 7.
2. Add mixed material hose as necessary between the mix hose (25) and cleanup mixer (27,28).

Connect Fluid Hose Bundles (Remote Only)

Connect additional fluid hoses to the fluid manifold (AA) when the mix manifold (AB) is remote. Hoses must be properly sized and balanced for your mix ratio. See mix manifold manual for details.

1. Connect the resin and hardener hoses to the resin and hardener outlets on the proportioner fluid manifold and resin and hardener inlets on the mix manifold.

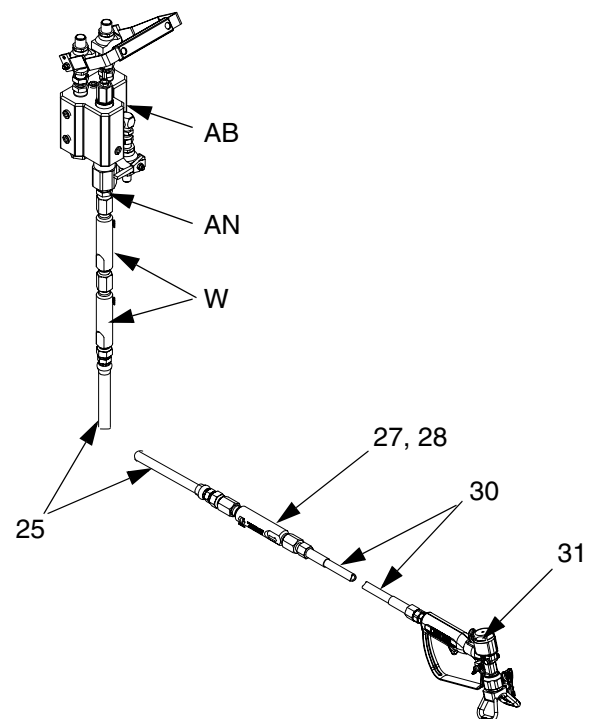





FIG. 7

Pressure Relief Procedure

						
<p>Follow Flush Mixed Material, page 26 when you stop spraying or dispensing; and before cleaning, checking, servicing, or transporting equipment.</p>						

Relieve A and B Fluid Pressure

1. Engage the trigger lock.



TI1949a

2. Close the main air shutoff valve (CA).

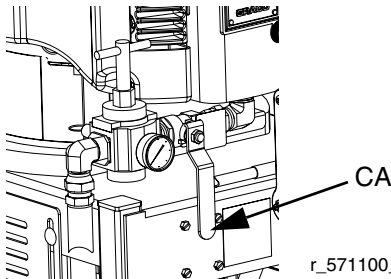

r_571100_3A0420A_11a-1

3. Shut off heaters, if used.
4. Shut off feed pumps, if used.
5. Remove the spray tip and clean.
6. Disengage the trigger lock.

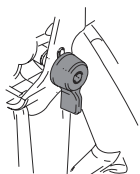

TI1950a

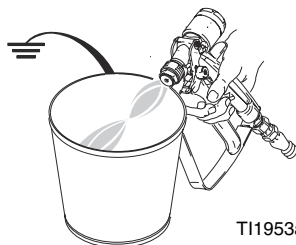

TI1953a

7. Hold a metal part of the gun firmly to a grounded metal pail. Trigger the gun to relieve pressure.

8. Engage the trigger lock.
9. Close the dual shutoff handle (AE) and open the circulation handle (AC).

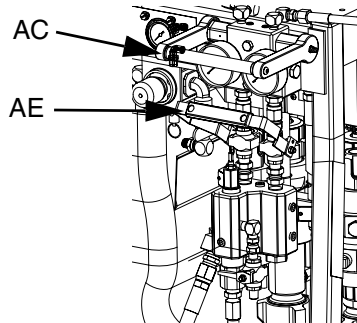

r_571101_3A0420A_9a-2

10. Always flush the mix hose after relieving A and B fluid pressure through the mix manifold. See **Flush Mixed Material**, page 26.
11. Shutoff the solvent supply pump and repeat steps 6-8 to relieve solvent pressure.

If the mixed material has already been flushed, but pressure remains on the A and B pumps, pressure can be relieved back to the hoppers (J).

- a. Close the main air shutoff valve (CA).
- b. Open the circulation handle (AC).

NOTE: For longer valve life in abrasive fluids, it is advisable to relieve high pressure out through the gun when possible.

12. If you suspect the spray tip or hose is clogged or that pressure has not been fully relieved after following the steps above, very slowly loosen tip guard retaining nut or hose end coupling to relieve pressure gradually, then loosen completely. Clear hose or tip obstruction.
13. If static mixer, whip hose, and gun cannot be flushed because of mixed and cured material, very slowly loosen static mixer tube from mix manifold outlet to relieve pressure gradually, then loosen completely. Replace or clean clogged components.

Prime Empty Sprayer

Prime A and B Fluids

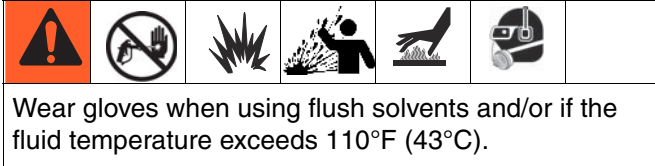

NOTE: The equipment is tested with mineral oil at the factory. If necessary, flush out the oil with a compatible solvent before spraying. See **Empty and Flush Entire System (new sprayer or end of job)**, page 27.

Do not install the gun spray tip yet. To avoid splashing, use the lowest pressure possible to prime.

1. Condition the materials prior to adding to the hoppers (J). Ensure that the resin materials are thoroughly mixed, homogenous, and pourable prior to adding to the hopper. Stir the hardeners back into suspension prior to adding material to hopper.
2. Fill the A and B reservoirs with proper materials. Fill the A side (blue) with major volume of material; fill the B side (green) with minor volume of material (unless 1:1 mix ratio).

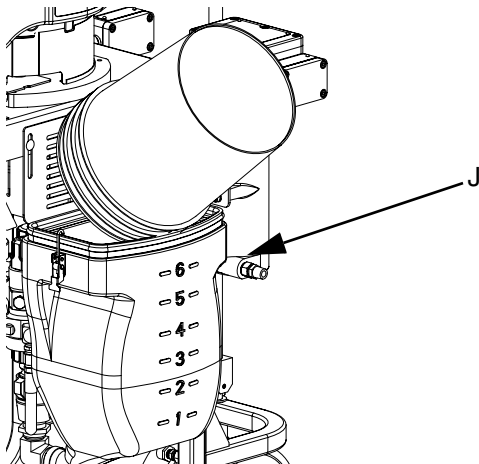

3. Move the recirculation lines (U) to empty containers.

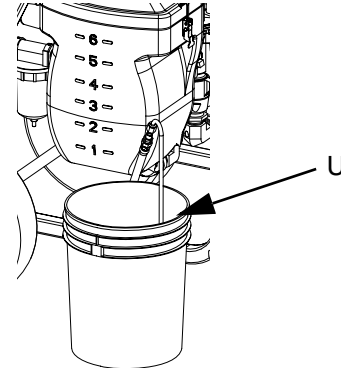

4. Close the dual shutoff handle (AE) and open the circulation handle (AC).

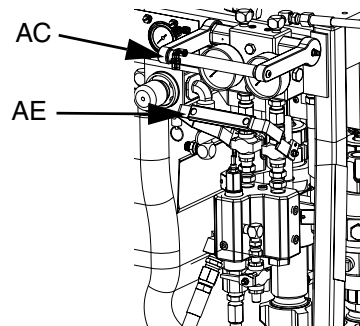

r_571101_3A0420A_9a-2

5. Open the main air shutoff valve (CA).

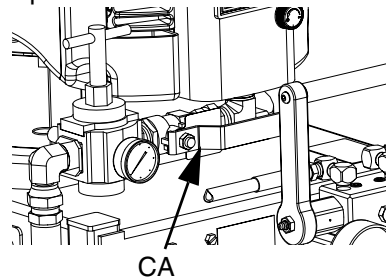

6. Slowly open the air regulator (CB).
7. Dispense fluid in to the containers until clean fluid comes out of the A and B recirculation lines.
8. Decrease air pressure. Close the main air shutoff valve (CA).
9. Move the recirculation lines (U) back to the correct hopper (J).
10. If using heaters, heat fluid throughout system before spraying. See **Recirculate or Re-Prime After a Pump Runs Dry**, page 23.

Prime Solvent Flush Pump

Follow instructions if the optional solvent flush pump kit is used.



1. Connect the flush pail ground wire to a metal pail of solvent.
2. Place the siphon tube and the solvent circulation hose (BG) in the pail of solvent.

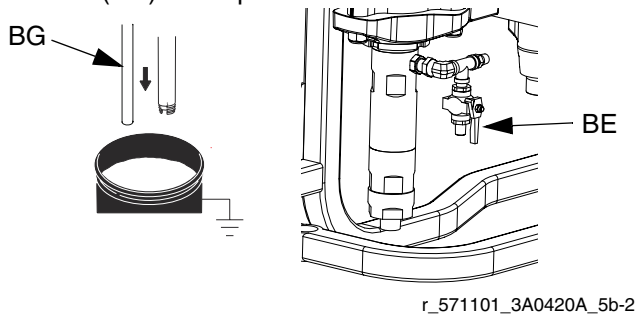

3. Open the solvent prime valve (BE) on the solvent pump (BA) outlet.
4. Open the solvent pump air valve (DA). Slowly turn the solvent pump air regulator (DB) clockwise to prime the solvent pump and back to the pail. Close the solvent pump fluid valve (BE) and air valve (DA).

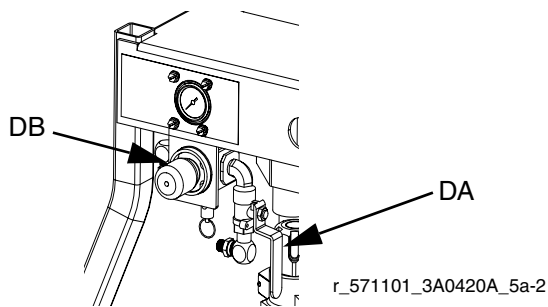

5. Open the solvent flush valve (AD) on the mix manifold.

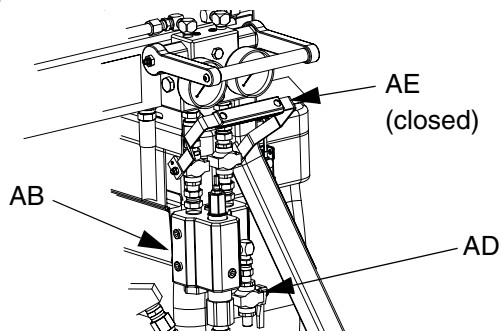

6. Ensure the trigger lock is engaged. Remove the spray tip.

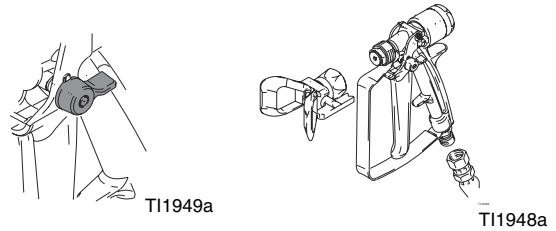

7. Disengage the trigger lock and trigger the gun into a grounded pail. Use a pail lid with a hole to dispense through. Seal around the hole and gun with a rag to prevent splash back. Be careful to keep fingers away from the front of the gun.

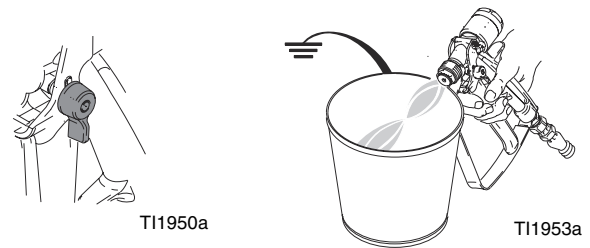

8. Open the solvent pump air valve (DA). Slowly turn the solvent pump air regulator (DB) clockwise to prime the solvent pump and push air out of the mix hose and gun. Trigger the gun until all air is purged.
9. Close the solvent pump air valve (DA) and trigger the gun to relieve pressure. Engage the trigger lock.

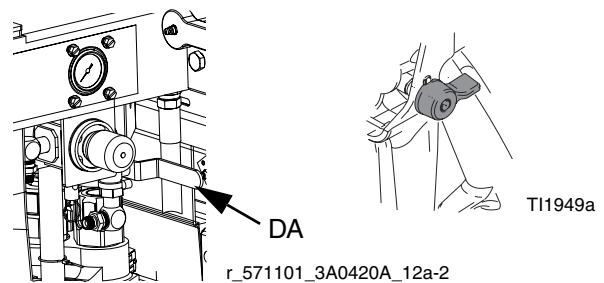

10. Close the solvent flush valve (AD).

NOTE: Solvent pump air and pressure may be left on while spraying. Never spray mixed material without the solvent pump and hose primed with solvent.

Recirculate or Re-Prime After a Pump Runs Dry

Without Heat

If using a system that does not require heat, recirculation is still required prior to spraying. Recirculation ensures that any settled fillers are mixed in, the pump lines are fully primed, and the pump check valves are operating smoothly.

Recirculation also allows you to re-prime one side that has run dry.

1. Follow **Prime Empty Sprayer**, page 21.
2. Close the dual shutoff handle (AE).

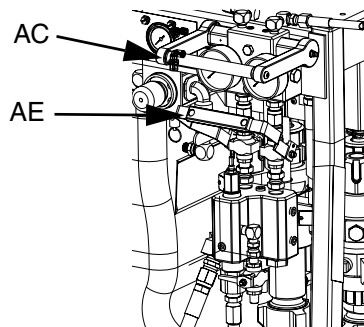

r_571101_3A0420A_9a-2

3. Ensure the recirculation hoses (U) are in the correct hoppers (J).

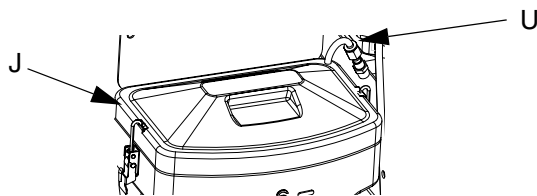

4. Open the circulation valve handle (AC).
5. Turn down the air pressure regulator (CB) and then open the main air shutoff valve (CA). Use the air pressure regulator to slowly increase the air pressure to the pumps until they start running slowly.

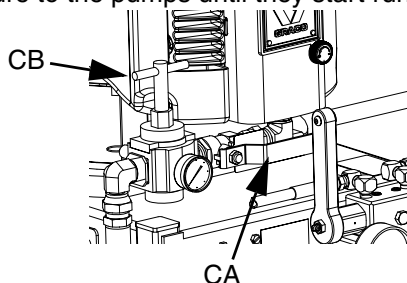

6. If the pumps are running too quickly, adjust the main air regulator (CB) to regulate the cycle rate.
7. Run the pumps for a few minutes or until the material has reached the desired temperature. See **Heat Fluid**.
8. Close the main air shutoff valve (CA).

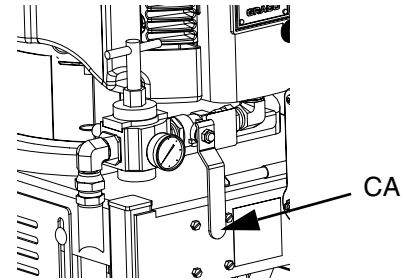

r_571100_3A0420A_11a-1

9. See **Spray**, page 24.

With Heat

Use the recirculation mode when heating the material is required. Note the temperature at the top of the heater (outgoing or back to the hopper). When the thermometer reaches operating temperature, the material is ready to spray.

Heat Fluid







To heat fluid evenly throughout the system:

1. Circulate the fluid at approximately 1/2 gpm (10-20 cycles/min.) to raise the temperature of the hoppers to 80-90° F (27-32° C).
2. Decrease the circulation rate to approximately 0.25 gpm (5 cycles/min.) to increase the heater outlet temperature to match the spray temperature.

NOTE: Circulating the fluid too quickly without decreasing the circulation rate will increase only the hopper temperature. Similarly, circulating fluid too slowly will increase only the heater outlet temperature.

NOTE: Agitate, recirculate, and heat the material only as necessary to avoid mixing air into the fluid.

Spray

						
Wear gloves when using flush solvents and/or if fluid temperature exceeds 110°F (43°C).						

NOTE: After the first day of spraying follow Pressure Relief Procedure, page 20, and tighten the throat packing nuts on both pumps.

1. If heaters are used, turn them on. To adjust the heater temperature, refer to the Viscon HP manual for instructions, and the **Heat Fluid** section, page 23. Circulate as necessary.
2. Close the circulation handle (AC) and the solvent flush valve (AD). Open the dual shutoff handle (AE).

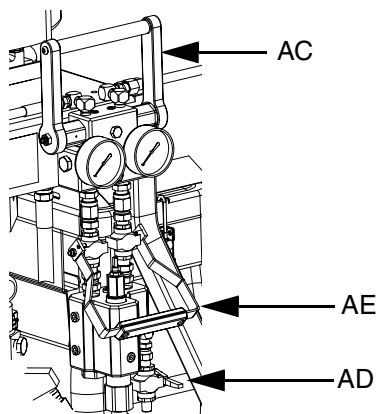

3. Adjust the main air regulator (CB) to 30 psi (0.21 MPa, 2.1 bar).
4. Remove tip. Disengage the trigger lock and trigger the gun into a grounded metal pail. Use a metal pail lid with a hole to dispense through to avoid splashing. Dispense flush solvent out of the mix hose until a well mixed coating flows from the gun.

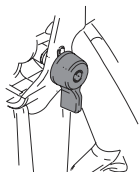

TI1950a



TI1953a

5. Engage the trigger lock. Install the tip on the gun.

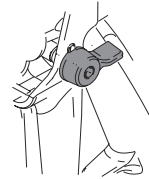

TI1949a

6. Adjust the main pump air regulator (CB) to the necessary spraying pressure and apply a coating to a test panel.

NOTE: Run system verification tests everyday. See page 29.

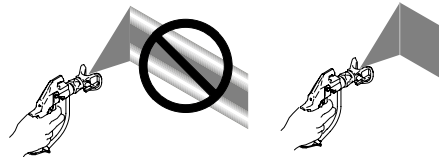

7. Excess pressure increases overspray and pump wear.
8. Check and record gauge readings frequently during operation. A change in gauge readings indicates a change in system performance.

NOTE:

- **A pressure drop occurs during pump stroke changeover. It should be quick and synchronous.**
 - **Flush the mix manifold as necessary during the day's operation.**
9. Follow **Flush Mixed Material**, page 26 when you are finished spraying or before potlife expires.

NOTE: Mixed material potlife or working time decreases with increased temperature. Pot life in the hose is much shorter than the dry time of the coating.

B Side Mix Manifold Restriction

If the mix manifold (AB) is mounted on the machine, you do not need to adjust the restrictor (AJ). Leave open two turns minimum.

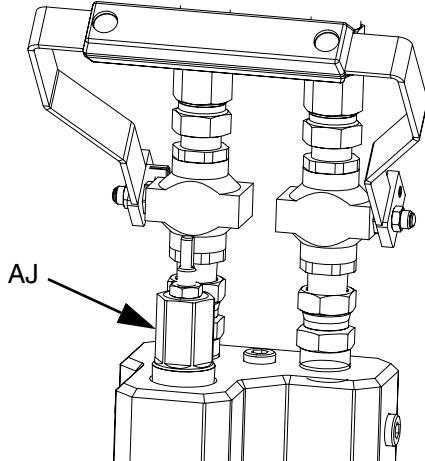

The B side restrictor (AJ) in the mix manifold is only used when the mix manifold is positioned remote from the machine with a short mix hose to the spray gun, or it has been adjusted as part of the ratio check procedure.

The B side restrictor (AJ) controls “lead/lag” ratio errors of the A and B flow into the static mixer tubes. These errors occur momentarily when the gun opens. The error is caused by differences in viscosity, volume, and hose expansion.

Adjust the restrictor stem (AJ) clockwise while spraying until you see a slight rise in the B side pressure gauge. The point where the pressure starts to rise is a good adjustment setting.

NOTE: Unless you are dispensing directly out of the mix manifold and mixer, this is an approximate adjustment.

See the mix manifold manual for more information.

Flush Mixed Material



Flush the mix manifold when any of the following situations occur.

- breaks in spraying
- overnight shutdown
- end of potlife

To flush the entire system, see **Empty and Flush Entire System (new sprayer or end of job)**, page 27.

Flush Mix Manifold, Hose, and Spray Gun

If your system doesn't include a solvent flush pump, see step 2 of **Empty and Flush Entire System (new sprayer or end of job)**, page 27.

Turn off heaters. Allow heater and heated hoses to cool.

Use Optional Solvent Pump

1. Close the main air shutoff valve (CA) to turn off the system. Engage trigger lock. Remove the spray tip and soak in solvent.

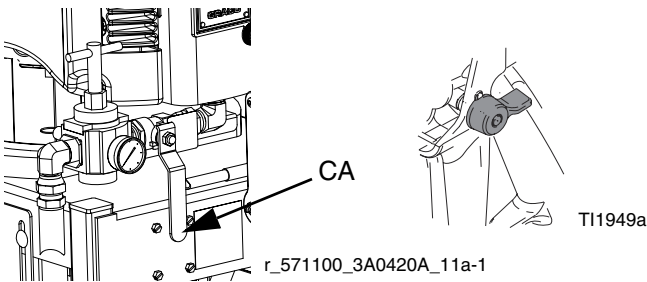

2. Close the dual shutoff handle (AE).
3. Open the solvent pump air valve (DA). Slowly turn the solvent pump air regulator (DB) clockwise to increase air pressure.

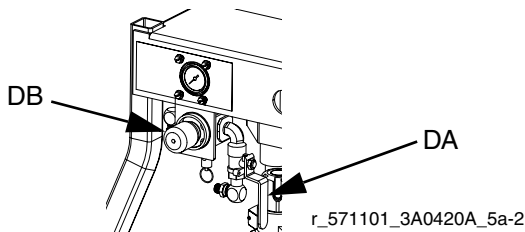

4. Open the solvent flush valve (AD).

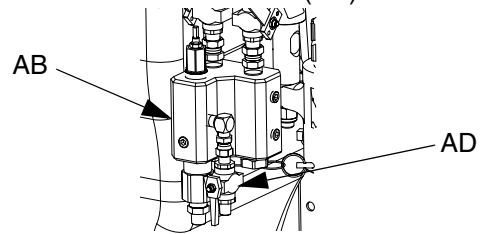

5. Disengage the trigger lock and trigger gun into a grounded pail. Use a pail lid with a hole to dispense through. Seal around the hole and gun with a rag to prevent splash back. Be careful to keep fingers away from the front of the gun. Flush out mixed material until clean solvent dispenses.

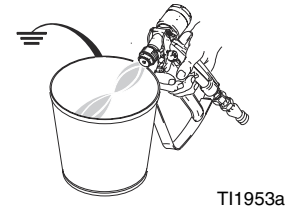
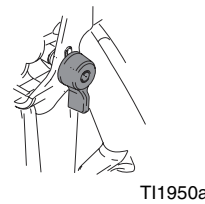

6. Close the solvent pump air valve (DA). Trigger the gun to relieve pressure. Close the solvent flush valve (AD) after relieving the pressure.

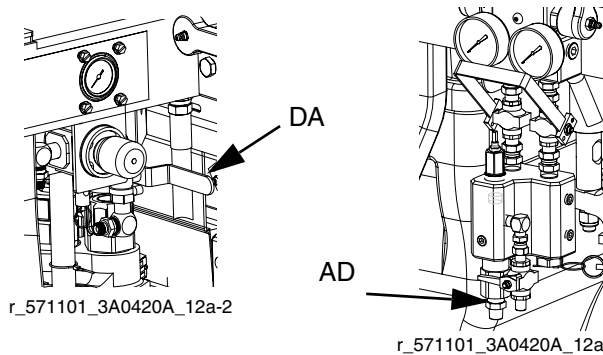

7. Follow **Pressure Relief Procedure**, page 20.

8. Engage the trigger lock. Disassemble and clean the spray tip with solvent by hand. Reinstall on the gun.

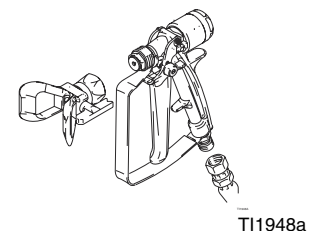
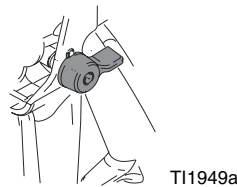

Empty and Flush Entire System (new sprayer or end of job)



NOTE:

- If the system includes heaters and heated hose, turn them off and allow to cool before flushing. Do not turn on the heaters until the fluid lines are clear of solvent.
- Cover fluid containers and use the lowest possible pressure when flushing to avoid splashing.
- Before color change or shutdown for storage, circulate the solvent at a higher flow rate and for a longer time. Change the solvent when it gets dirty.
- To only flush the fluid manifold, see Flush Mix Manifold, Hose, and Spray Gun, page 26.
- If the machine is inoperable, use drain plugs on the pump inlet fittings.

Guidelines

Flush new systems if the coating materials will be contaminated by mineral oil.

Flushing will help prevent materials from settling or gelling in the pumps, lines, and valves. Flush the system when any of the following situations occur.

- anytime the sprayer will not be used for more than one week (depending on materials used)
- if the materials used have fillers that will settle
- if using materials that are moisture sensitive
- before servicing
- If the machine is going into storage, replace the flush solvent with light oil. Never leave the equipment empty of any fluid.

Procedure

1. Follow **Prime Empty Sprayer**, page 21 and **Flush Mix Manifold, Hose, and Spray Gun**, page 26, as required.

2. Engage the trigger lock. Turn the main pump air regulator (CB) fully counter-clockwise to shut off.

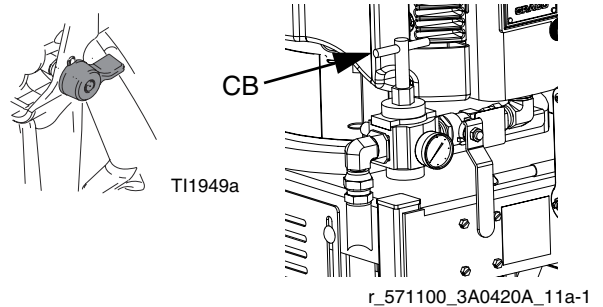

3. Move the recirculation lines (U) to separate fluid containers to pump remaining fluid out of the system.

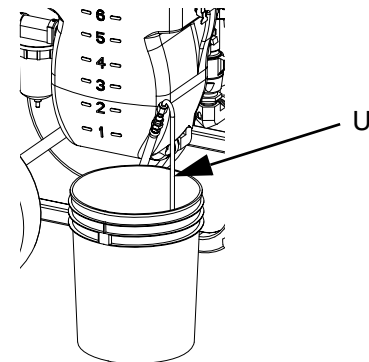

4. Open the circulation handle (AC). Increase the main pump air regulator (CB) pressure to 20 psi (138 kPa, 1.38 bar).
5. Open the main air shutoff valve (CA).

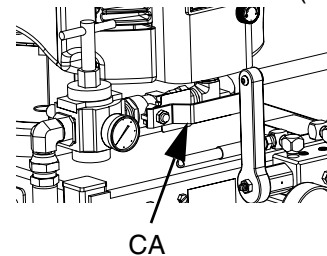

NOTE: If the sprayer does not start with static pressure, increase the air pressure by 5 psi (35 kPa, 0.35 bar) increments. To avoid splashing, do not exceed 35 psi (241 kPa, 2.4 bar).

Shutdown

- Run the pumps until the A and B hoppers (J) are empty. Salvage the material in separate, clean containers.
- Close the main air shutoff valve (CA).

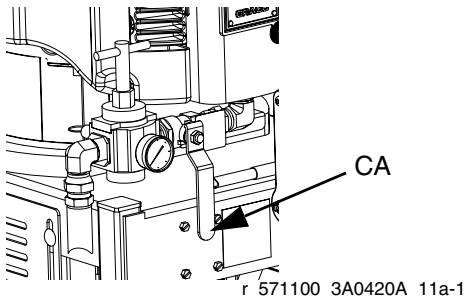

- Wipe the hoppers (J) clean, then add solvent to each. Move the circulation lines (U) to waste containers and push out the dirty fluids.
- Move the recirculation lines (U) back to the hoppers. Continue recirculating until the system is thoroughly flushed.

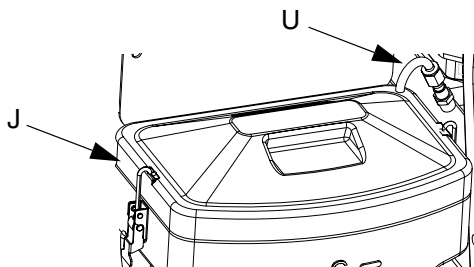

- Close the circulation handle (AC) and open the dual shutoff handle (AE).
- Dispense fresh solvent through the mix manifold valves and out the gun. Turn off the air motors and relieve all pressures.

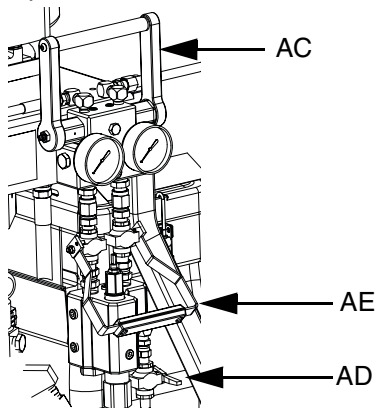

- Close the dual shutoff handle (AE).
- Remove pump fluid filters, if installed, and soak in solvent. Clean and replace the filter cap. Always replace the filter o-rings.

NOTE:

- Fill the A and B pump packing nuts with TSL. Also, always leave some type of fluid, such as solvent or oil, in the system to prevent scale build up. This build up can flake off later. Do not use water.
- If machine is set up with a remote mix manifold, the A and B hose can be disconnected from the mix manifold, and secured in back of each hopper for circulation of flush solvent.
- Change the flush solvent at least once until it circulates clean.
- Always keep the A side and B side flush solvent separate.

Shutdown

- Follow **Pressure Relief Procedure**, page 20.
- Flush mix manifold, hoses, and gun. See **Flush Mix Manifold, Hose, and Spray Gun**, page 26.
- Close the main air shutoff valve (CA).

Park

- Open the circulation handle (AC) and adjust the air regulator (CB) so that the pump runs slowly.
- Close the circulation handle (AC) when the pump is at the bottom of the stroke.
- Close the air regulator (CB) and open the circulation handle (AC).

System Verification

Graco recommends running the following tests daily.

Check for Normal Operation

Every time you start spraying:

- Watch the fluid gauges (AF). A pressure drop occurs during pump stroke changeover. It should be quick and synchronous.
- Stop the pumps on the upstroke. Check that both gauges hold pressure for at least 20 seconds. See **Pump Troubleshooting** on page 32.

NOTE: If one gauge drops, the others will rise.

- Stop the pumps on the downstroke. Check that all gauges hold pressure.
- If using feed pumps, check that both feed pumps run during the proportioner upstroke.

Mix and Integration Tests

Use the following tests to check for proper mix and integration.

Butterfly Test

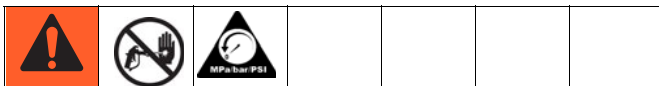

At low pressure, and with the spray tip reversed, dispense a 1/2 in. (12.7 mm) bead of material onto foil until multiple changeovers of each pump have occurred. Fold the sheet of foil over the fluid then peel it back and look for unmixed material (appears marble-like), or color changes.

Curing Test

Spray a single continuous pattern on foil at typical pressure setting, flow rate, and tip size until multiple changeovers of each pump have occurred. Trigger and de-trigger at typical intervals for the application. Do not overlap or cross over your spray pattern.

Check curing at various time intervals, listed on the material data sheet. For example, check for dry to touch by running your finger along the test pattern's entire length at the time listed on the data sheet.

NOTE: Spots that take longer to cure indicate insufficient pump loading, leakage, or lead/lag errors at a remote mix manifold.

Appearance Test

Spray material onto a metal substrate. Look for variations in color, gloss, or texture that may indicate improperly catalyzed material.

Monitor Fluid Supply

NOTICE

To prevent pumping air into the system and cause incorrect proportioning, never allow the feed pump or solvent pump containers to run dry.

An empty pump will quickly accelerate to a high speed, and may damage itself and the other displacement pump because it causes a pressure rise in the other pump. If a supply container runs dry, stop the pump immediately, refill the container, and prime the system. Be sure to eliminate all air from the system.

Check Pot Life

Check the fluid manufacturer's instructions for fluid pot life at your fluid temperature. Flush mixed fluid out of the mix manifold, hose, and gun before pot life time expires, or before a rise in viscosity affects the spray pattern.

Ratio Check

Check the ratio at the mix manifold after any changes to the proportioning system. Use Ratio Check Kit 24F375 to check the ratio at the mix manifold. See manual ratio check kit manual for instructions and parts.

NOTE: To prevent an inaccurate ratio check when feed pumps are used in your system, the feed pressure cannot be more than a maximum of 25% of the proportioner outlet pressure. High feed pressure can float the proportioner pump check balls, resulting in an inaccurate ratio check. There must be back pressure on both sides of the mix manifold when checking the ratio.

Maintenance

Filters

Once a week check, clean, and replace (if needed) the following filters.

- Both pump filters; see lower manual for instructions.
- Main air inlet manifold filter; see **Replace Air Filter Element**, page 34.
- Spray gun handle filter; see spray gun manual.

Seals

Once a week, check and tighten throat seals on both pumps. See table for torque specifications. Be sure to follow the **Pressure Relief Procedure**, page 20, prior to tightening seals. There must be zero pressure on the pumps when adjusting.

Pump Size	Torque Specification
36cc-85cc	50-75 ft-lb (68-100 N•m)
115cc and 145 cc	100-125 ft-lb (135-170 N•m)

Cleaning Procedure



1. Ensure all equipment is grounded. See **Grounding**, page 16.
2. Ensure the area where the sprayer will be cleaned is well ventilated; and remove all ignition sources.
3. Turn off all heaters and allow equipment to cool.
4. Flush mixed material. See **Flush Mixed Material**, page 26.
5. Relieve pressure. See **Pressure Relief Procedure**, page 20.
6. Shutdown the sprayer and turn off all power. See **Shutdown**, page 28.

7. Clean the external surfaces only using a rag soaked in solvent that is compatible with the spray material and surfaces being cleaned.
8. Allow enough time for the solvent to dry before using the sprayer.

Recommended Spare Parts

Keep these spare parts on hand to reduce downtime. See **Recommended Spare Parts**, page 48.

Change the Mix Ratio

In order to change the mix ratio, one or both pumps need to be replaced and the air motor needs to be re-positioned.

NOTE: Only Xtreme XP lower pumps come with a rod coupling.

1. Check the **Varying Parts** table on page 45 for the correct pump sizes.
2. Remove and replace pump. See page 33.
3. Adjust the position of the air motor. See page 18.
4. Change air pressure relief valve as required, depending on ratio. See air relief valve (64) in tables on page 43.

Troubleshooting



✘ *Fluid ratio will be wrong.*

◆ *Purge all air from system before proportioning fluids.*

Problem	Cause	Solution
System stops or will not start.	Air pressure or volume too low.	Increase; check air compressor.
	Closed or restricted air line or air valve.	Open or clean.
	Fluid valves closed.	Open.
	Clogged fluid hose.	Replace.
	Air motor worn or damaged.	Repair air motor; see 311238.
	Displacement pump stuck.	Repair pump; see 311762.
System speeds up or runs erratically.	Fluid containers are empty.◆	Check often; keep filled.
	Air in fluid lines.◆	Purge; check connections.
	Displacement pump parts worn or damaged.	Repair pump; see 311762.
Pump operates, but resin output pressure drops on upstroke.✘	Dirty, worn, or damaged resin pump piston valve or piston packings.	Clean, repair pump; see 311762.
Pump operates, but resin output pressure drops on downstroke.	Dirty, worn, or damaged resin pump intake valve.	Clean, repair pump; see 311762.
Pump operates, but resin output pressure drops on both strokes.✘	Hardener output restriction.	Clean, unplug hardener side. Open manifold restrictor.
	Fluid supply low.◆	Refill or change container.
Pump operates, but hardener output pressure drops on upstroke.✘	Dirty, worn, or damaged hardener pump piston valve or piston packings.	Clean, repair pump; see 311762.
Pump operates, but hardener output pressure drops on downstroke.✘	Dirty, worn, or damaged hardener pump intake valve.	Clean, repair pump; see 311762.
Pump operates, but hardener output pressure drops on both strokes.	Resin output restriction.	Clean, unplug resin side.
	Fluid supply low.◆	Refill or change container.
Fluid leak in packing nut.	Loose packing nut or worn throat packings.	Tighten; replace; see 311762.
Fluid leak under packing nut	Packing cartridge o-ring.	Replace o-ring; see 311762
Relief valve (AM) leaks back to supply, opens too soon, or will not close.	Relief valve is dirty or damaged.	Replace valve cartridge (302) with kit 262520.
No pressure on hardener side; fluid leaking from hardener pump outlet rupture disc fitting.	Overpressure rupture disk blown.	Determine cause of overpressurization and correct. Replace rupture disk assembly (140) and over-pressure cartridge (302).
Pressure and flow surges on upstroke.	Feed pressure too high. Every pound of feed pressure adds 2 psi boost during upstroke.	Reduce feed pressure. See Technical Data , page 53.

Problem	Cause	Solution
Fluid outlet pressure gauges split only at the top changeover (if one gauge drops, the others will rise).	Not fully loading one side on upstroke.	Increase feed pressure on side that dropped. Increase feed hose size. Clean inlet strainer or hopper screen.
	Air mixed in fluid from excessive agitation or circulation.	Flush and add new fluid.

Pump Troubleshooting

This chart uses proportioning fluid gauges to determine pump malfunctions. Observe the gauge readings during the stroke direction indicated by the bold arrow, and immediately after closing the gun or mix manifold. Refer to other manuals to troubleshoot individual components.

TROUBLE AREA: Resin Pump Leakage

1. Throat packing
2. Piston packing
3. Piston ball check

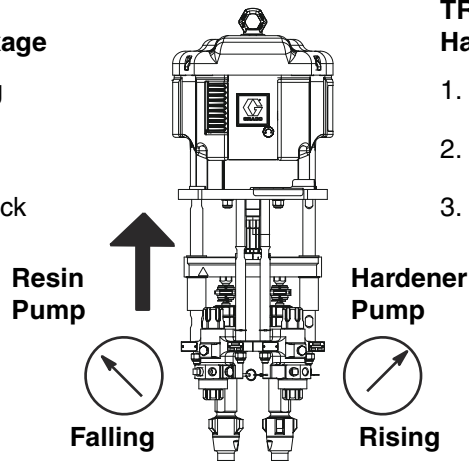

r_258914_3a0420a_11a

TROUBLE AREA: Hardener Pump Leakage

1. Throat packing
2. Piston packing
3. Piston ball check

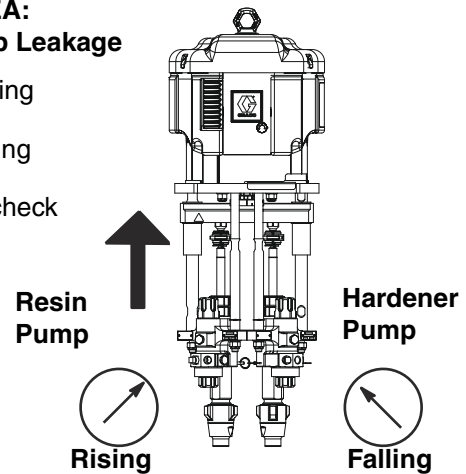

r_258914_3a0420a_11a

TROUBLE AREA: Resin Pump Leakage

1. Throat packing
2. Intake ball check

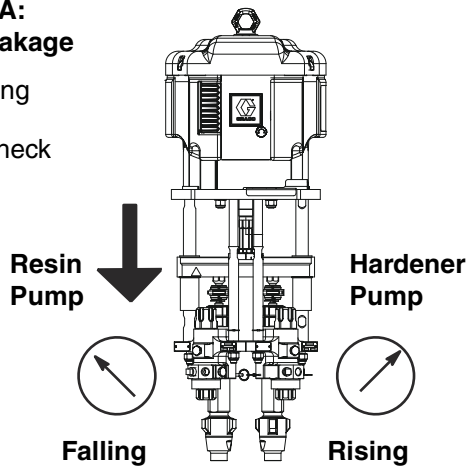

r_258914_3a0420a_10a

TROUBLE AREA: Hardener Pump Leakage

1. Throat packing
2. Intake ball check

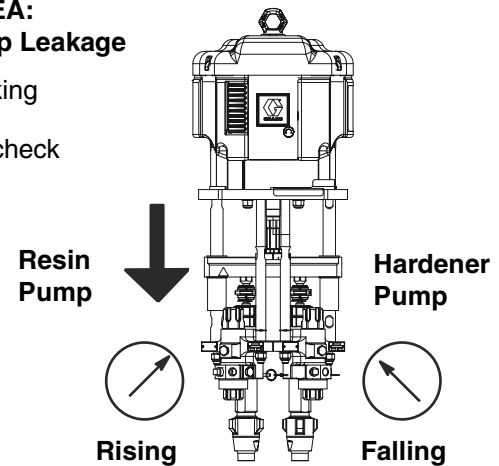

r_258914_3a0420a_10a

Repair

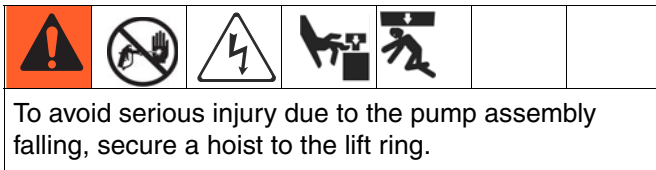

Follow **Shutdown**, page 28, if service time may exceed pot life time, before servicing fluid components, and before transporting sprayer to a service area.

Pump Assembly

The displacement pumps and air motor may be removed and serviced separately or the entire pump and motor assembly can be removed with a hoist.

Remove Pump Assembly

1. Cycle the yoke and pump rods near the bottom of their stroke. Follow **Shutdown**, page 28.
2. Disconnect all hoses from the pump assembly.
3. If hoppers are installed, disconnect the hoppers from the pump fluid inlet. See **Hoppers**, page 38.

NOTE: The hopper and hopper bracket do not need to be removed from the cart.

4. Remove screws (6) and washers (5) under the tie plate (101).
5. Use hoist to remove the pump assembly by the lift ring and carefully lift out of cart (1).

Remove Displacement Pump

1. Follow **Shutdown**, page 28.
2. If hoppers are installed, remove the hopper and hopper bracket from the cart. See **Hoppers**, page 38.
3. If feed pumps are installed, close the inlet ball valve. Remove inlet union (61).

4. Remove the spring clamp (130) and coupling (119 or 120).

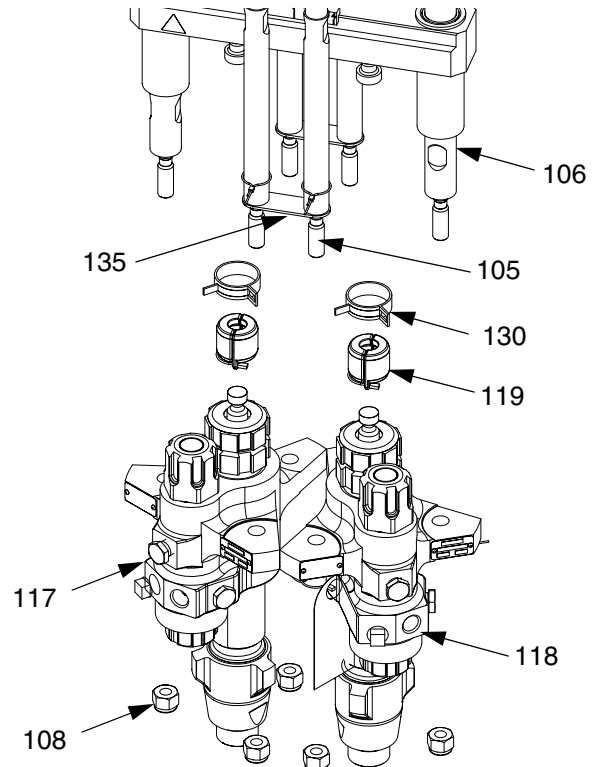

r_258914_3a0420a_5a

5. Use a wrench to hold the tie rod (105, 106) flats to keep the rods from turning. Unscrew the nuts (108) from the tie rods and carefully remove the displacement pump (117 or 118) and lower straps (135).
6. Refer to the Xtreme Displacement Pump manual to service or repair the displacement pump.
7. Follow the steps in reverse order to reinstall the displacement pump.

NOTE: Torque nuts (108) to 50-60ft-lb (68-81 N•m).

Remove Air Motor

1. Cycle the yoke and pump rods near the bottom of their stroke. Follow **Shutdown**, page 28.
2. Disconnect the air line from the air motor (103).
3. Remove the air motor rod cover (121) and pump guards (122).

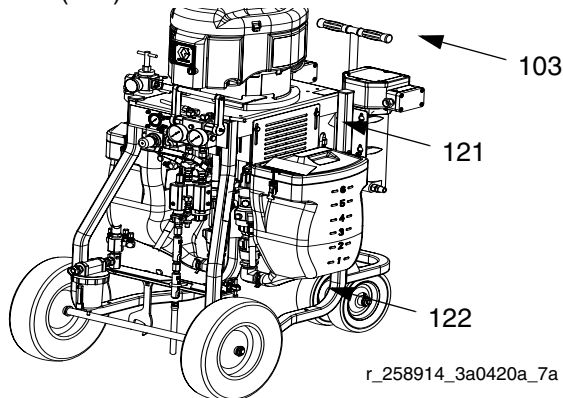

4. Use a wrench to hold the tie rod (102) flats to keep the rods from turning. Unscrew the nuts (108) and washers (107) from the tie rods.

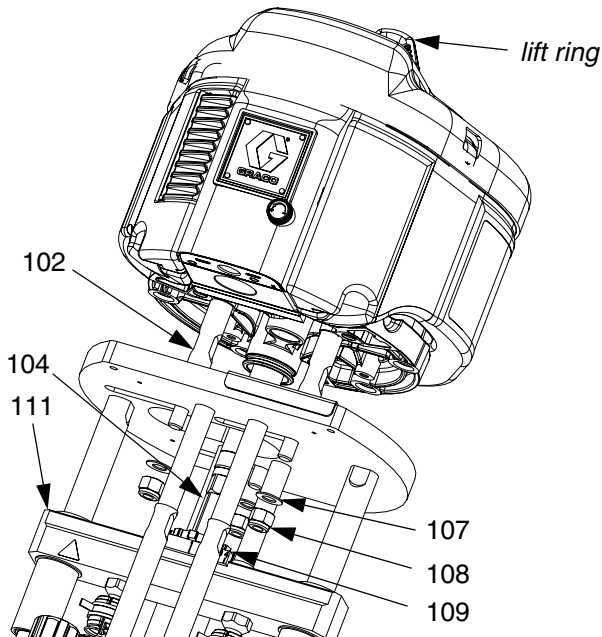

5. Place a wrench on adapter rod (104). Use tool (70) to loosen the serrated yoke nut (109) that holds the air motor (103) above the yoke (111).
6. Face the front of the machine and slide the air motor (103) to the opening in the yoke (111).
7. Use a hoist to remove the air motor by the lift ring.

8. Refer to the air motor manual to service or repair the air motor.
9. Follow the steps in reverse order to reinstall the air motor.

NOTE: Position air motor for correct mix ratio. See Air Motor Position on page 18 for instructions. Torque nuts (108) to 50-60ft-lb (68-81 N•m).

Air Controls

See FIG. 8 on page 35.

Replace Air Control Assembly

1. Close the main air shutoff valve on the air supply line and on the system. Depressurize the air line.
2. Disconnect the air motor air lines and system air line.
3. Remove the nut (8) and washer (5). Remove the bottom air control manifold assembly from the cart.
4. Loosen the upper air control assembly from the air motor.
5. Follow the steps in reverse order to reinstall the new air control assembly.

Replace Air Filter Element

1. Close the main air shutoff valve on the air supply line and on the system. Depressurize the air line.
2. Unscrew the serrated ring on filter bowl (210).
3. Remove and replace the filter element (210a). See **Air Controls, 258983**, page 46.

Replace System Air Regulator

1. Close the main air shutoff valve on the air supply line and on the system.
2. Disconnect air motor air lines and system air line.
3. Remove the regulator assembly (201) and replace with new regulator. See **Air Controls, 258983**, page 46.
4. Follow the steps in reverse order to reassemble.

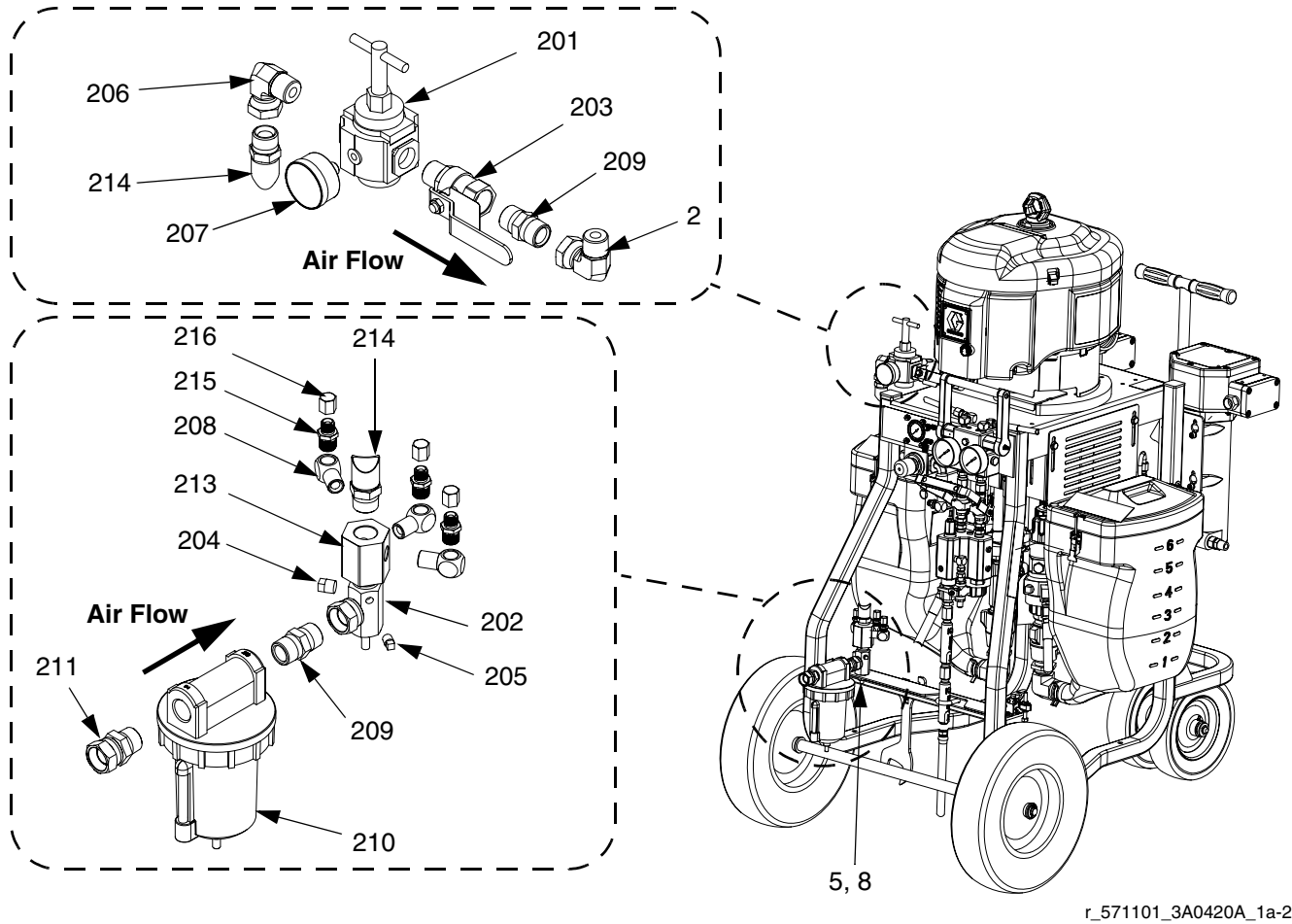

FIG. 8: Air Control Assembly 258983

Mix Manifold Assembly

1. Follow **Pressure Relief Procedure**, page 20.
2. Disconnect the fluid hose (25) and the flush hose from the mix manifold (36).
3. Loosen the union fittings (306) that connect to the mix manifold adapter fittings.
4. Remove the mix manifold assembly (36).
5. See mix manifold manual for service and repair instructions.

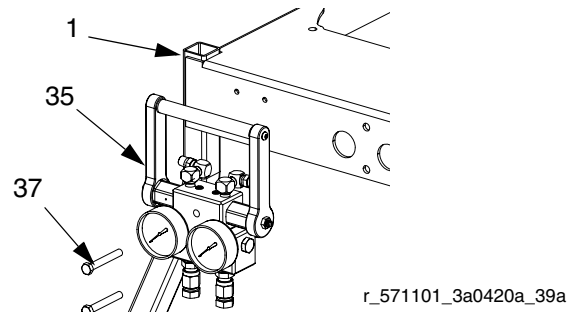
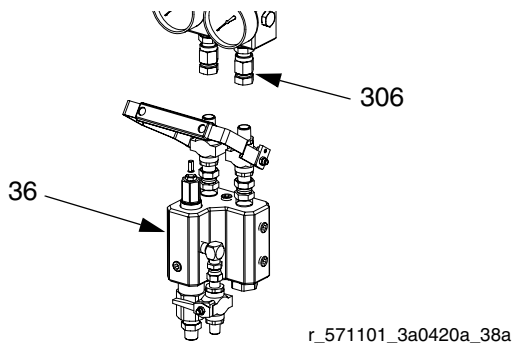
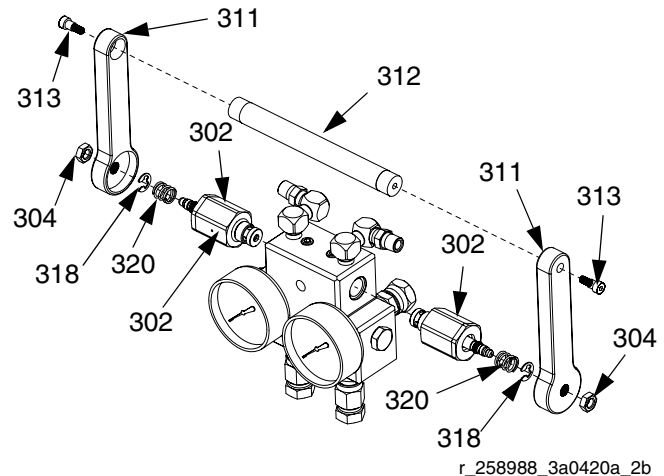

FIG. 9: Fluid Circulation Manifold

Replace Drain Valve Cartridges

1. Flush before repairing equipment, if possible. See **Empty and Flush Entire System (new sprayer or end of job)**, page 27.
2. Follow **Pressure Relief Procedure**, page 20.
3. Ensure handle (312) is in the down position. Remove the screws (313), jam nut (304), handles (311), handle rod (312), clips (318), and springs (320).



Fluid Circulation Manifold

See FIG. 9.

1. Flush before repairing equipment, if possible. See **Empty and Flush Entire System (new sprayer or end of job)**, page 27.
2. Follow **Pressure Relief Procedure**, page 20.
3. Disconnect all fluid hoses from the fluid circulation manifold (35).
4. Remove the mix manifold if it is assembled to the fluid circulation manifold. See **Mix Manifold Assembly** for instructions.
5. Loosen the two screws (37) that secure the manifold (35) to the cart (1).
6. Remove the two screws (37) and fluid circulation manifold (35) from the cart (1).

4. Unscrew both cartridge valves from the manifold.
5. Apply blue threadlock to new cartridge valves (302) and install in the manifold. Torque to (28-32 ft-lbs. (38-43 N•m)).
6. Place a spring (320) over each valve stem. Place a clip (318) in each valve stem groove to retain springs.
7. Slide on a handle (311) and turn the stem approximately 90° until you feel it fully lock against the valve seat. Repeat for opposite side.

8. Place a handle (311) on a valve stem (302) at the vertical, or near vertical, spray position.
9. Apply blue threadlock on the nut (304) threads and tighten the handle against the spring (320) and clip (318). Torque to 70-80 in.-lbs. (7.9-9 N•m).
10. Place the rod (312) and the second handle (311) on second valve stem aligned with the opposite handle.
11. Repeat step 9.
12. Install two screws (313) in handles (311).
13. Check operation of the handle and valves.
14. Operate the handle in and out of the spray and circulate positions.
15. Check for clearance with fittings.

NOTE:

- **Both valves should settle firmly into the spray position inward against the seats in the valve.**
- **Both valve stems should rotate out to their most extended positions when the handle is pulled down to the circulate position.**

Hoppers

1. If material is in the hopper pump out the remaining material.
2. If the pump has failed:
 - a. Place a waste container beneath the plug on fitting (61). Remove the plug.
 - b. Drain all material from hopper into the waste container.
 - c. Install plug after material is no longer draining from fitting (61).

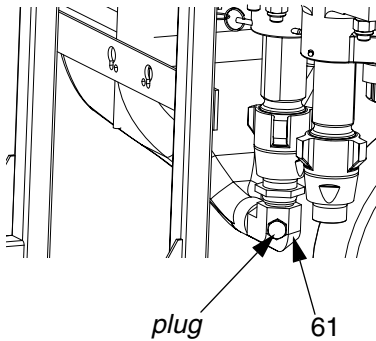

r_571101_3a0420a_41a

3. Follow **Pressure Relief Procedure**, page 20.
4. Loosen fitting (61) and disconnect hopper from pump.
5. Remove the recirculation line from the hopper and place in a waste container.

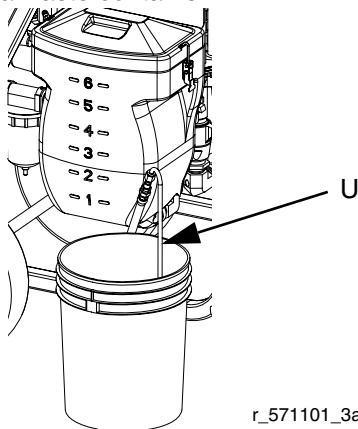

r_571101_3a0420a_18a

6. Lift the hopper off of the mounting bracket.
7. Repeat for second hopper.

Solvent Pump

1. Follow **Pressure Relief Procedure**, page 20.
2. Disconnect the fluid line and air lines from the solvent pump.
3. Loosen the four screws that attach the solvent pump to the cart (1). Lift and pull pump from the slots.

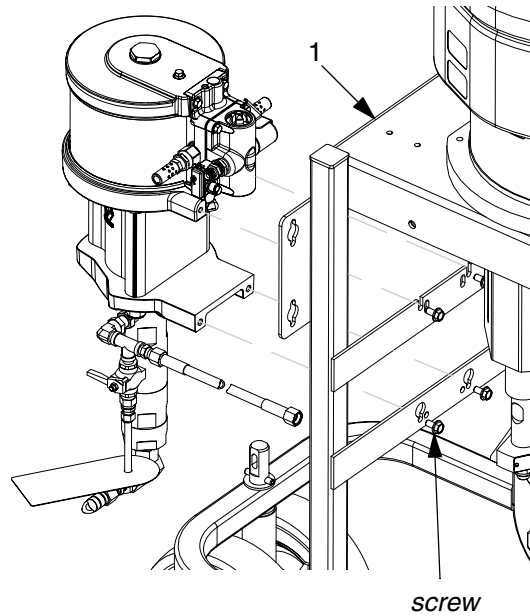

4. Refer to the Merkur Pump Assembly manual to service or repair the solvent pump.
5. Follow the steps in reverse order to reinstall the solvent pump.

Optional Fluid Heaters

NOTE: Wiring for heaters is not provided. See the Viscon HP heater manual for wiring, repair, and parts information for explosion-proof heaters.

Service and Repair

1. Follow **Pressure Relief Procedure**, page 20.
2. Disconnect the fluid lines and electrical wiring from the fluid heater.
3. Refer to the Viscon HP heater manual to service or repair. Refer to the heater adapter kit manual 406861 for installation instructions.
4. Reconnect the fluid lines and electrical wiring.

Replace

1. Follow steps 1 through 2 in the **Fluid Heaters Service and Repair** section.
2. Loosen the four mounting screws, lock washers, and plain washers on back of the heater. Slide the heater up and remove from the cart.
3. Replace the heater. Follow the steps in reverse order to install a new heater.

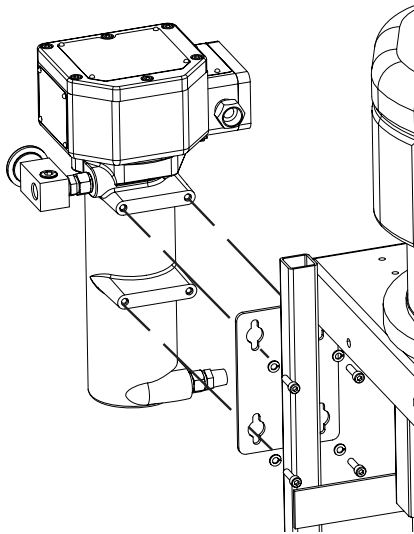

r_571101_3a0420a_42a

Parts

Cart-Mounted XP70 Sprayer

1. Apply anaerobic pipe sealant to all non-swiveling pipe threads.

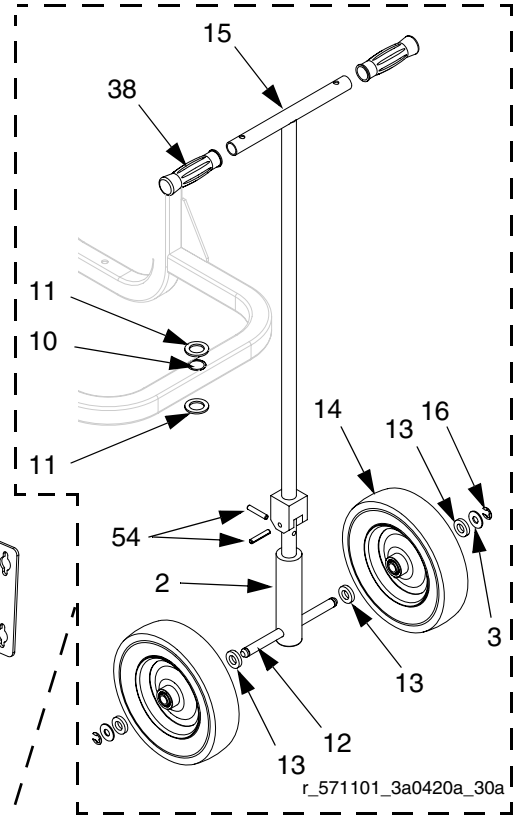
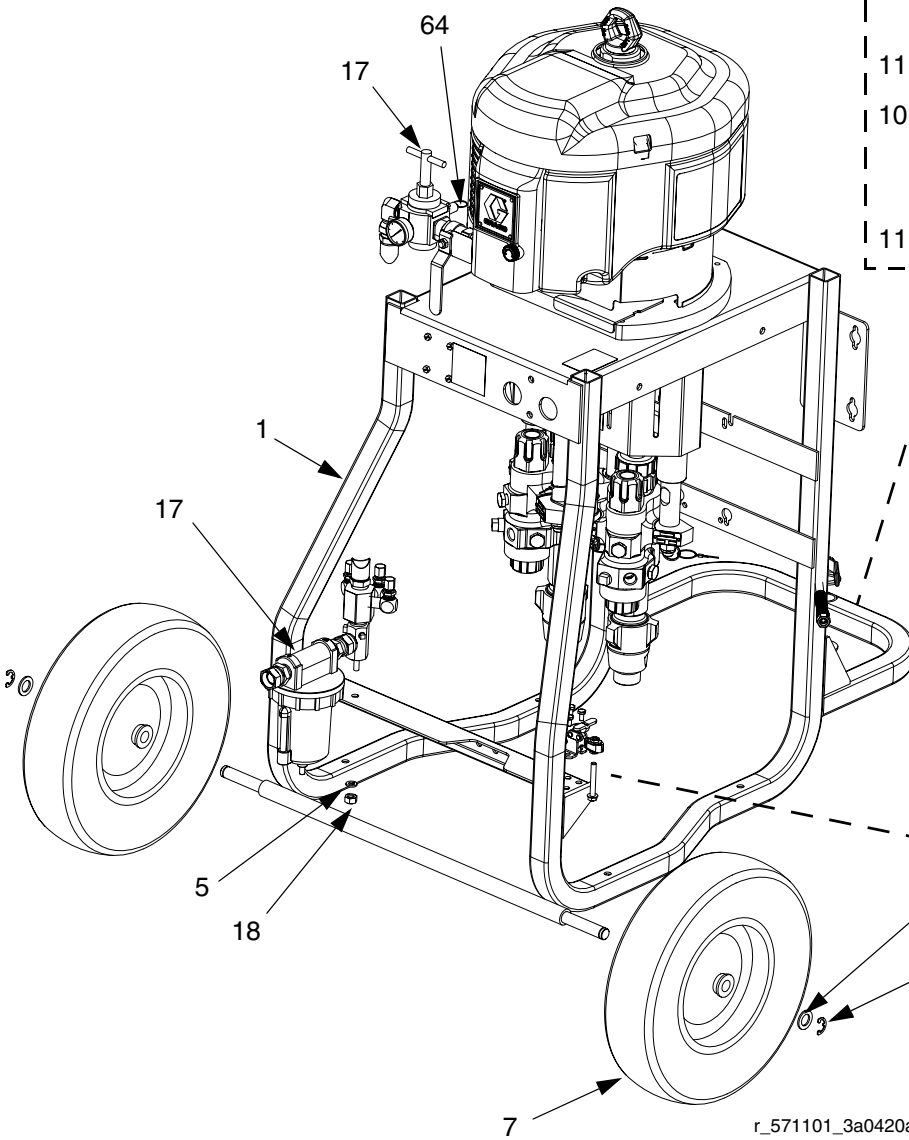

r_571101_3a0420a_30a

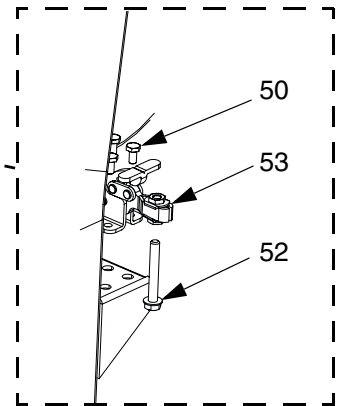

r_571101_3a0420a_30a

Cart-Mounted XP70 Sprayer Continued

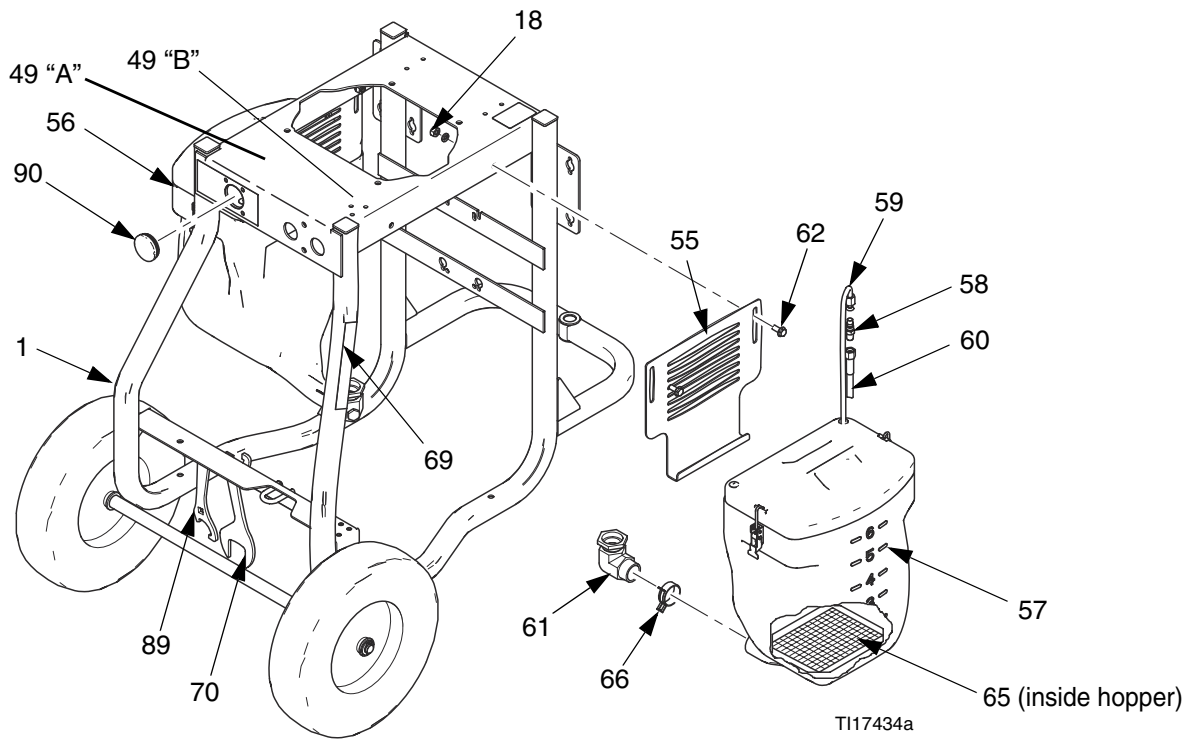
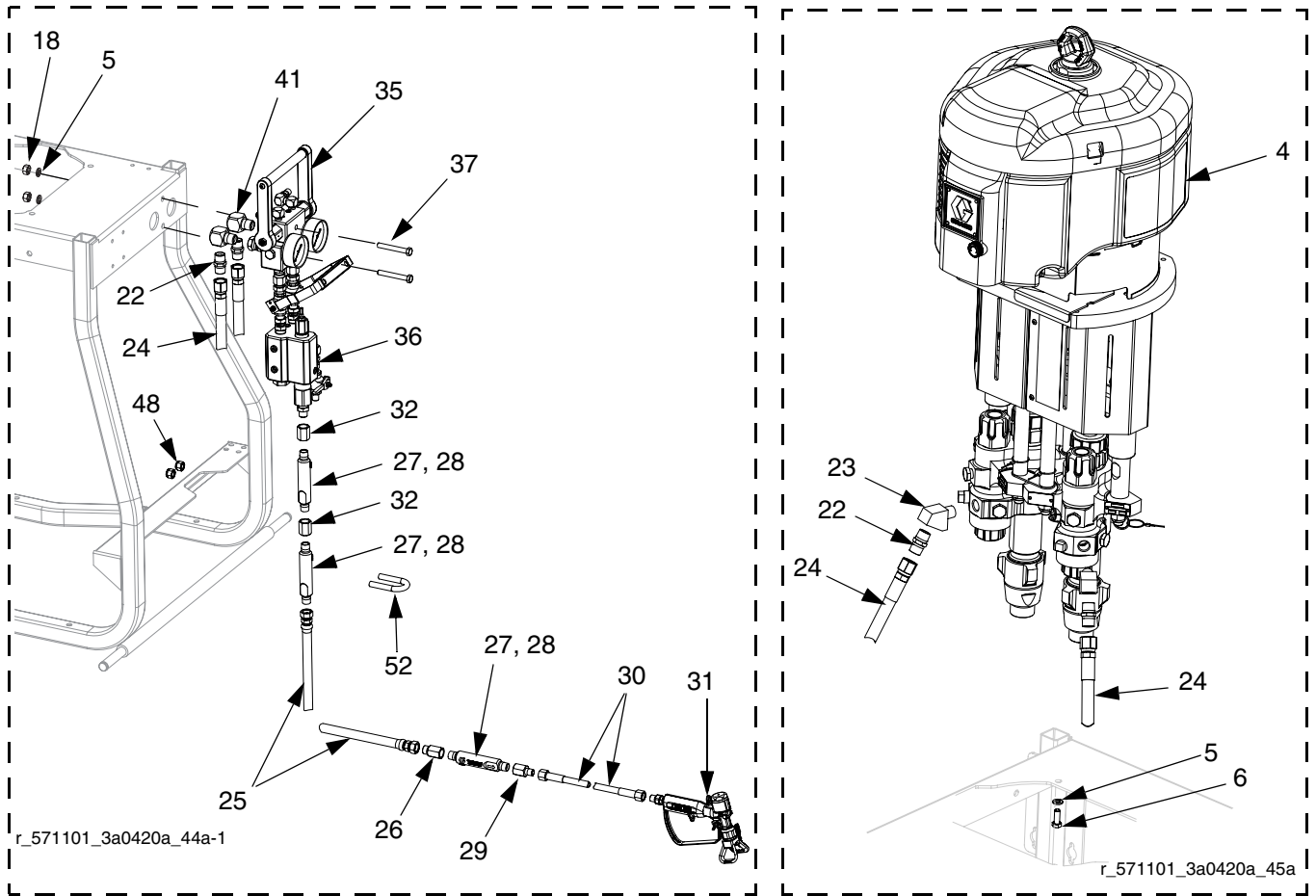

Common Parts

Ref.	Part	Description	Qty.	Ref.	Part	Description	Qty.
				50	100333	SCREW, hex hd, sst; 1/4 x 1/2 zn	4
				52	124293	BOLT, u-bolt, 3/8-16, 1 dia.	1
1	258913	CART	1	53	124259	BRAKE, plunger clamp	1
2	262476	AXLE, vertical	1	54	124291	PIN, spring	2
3	111841	WASHER, flat; 5/8	2	58	116704	ADAPTER, 9/16-18 JIC x 1/4 npt	2
4		PACKAGE, pump; see page 44	1	59	262481	TUBE, recirculation	2
5	100133	WASHER, lock; 3/8	7	65	16791	STRAINER	1
6	100101	SCREW, cap, hex hd; 3/8-16 x 1	4	68✘	114958	STRAP, tie	2
7	113362	WHEEL, semi-pneumatic	2	69▲	15U654	LABEL, warning	1
8	154628	WASHER; 3/4	2	70	16F615	TOOL, yoke nut, wet cups, and pump inlets	1
9	113436	RING, retaining	2	89	16G819	TOOL, wrench, filter cap	1
10	124410	BEARING, sleeve, 1.00 x 1.25 x 1.5	1	90	16J688	PLUG, hole gauge	1
11	124664	WASHER, thrust	2				
12	262477	AXLE	1				
13	191824	WASHER, space	4				
14	113807	WHEEL, flat free, urethane	2				
15	258982	HANDLE, cart	1				
16	101242	RING, retaining, ext.	2				
17	258983	MODULE, air controls, inlet; see page 46	1				
21	111218	CAP, tube, square	4				
22	158491	FITTING, nipple; 1/2 in., 7400 psi	4				
23	15M987	FITTING, elbow, 60°; 1/2 in., 7250 psi	2				
24	H75003	HOSE, coupled, 7250 psi, 1/2 ID, 3 ft	2				
25	H73825	HOSE, coupled, 7250 psi, 3/8 ID, 25 ft	1				
26	15B729	COUPLING; 3/8 m x f, 7250 psi	1				
27	262478	HOUSING, mixer	3				
28	248927	KIT, mixer element, 25 pack	1				
29	150287	COUPLING; 3/8(f) x 1/4(m), 7250 psi	2				
30	H72510	HOSE, coupled, 7250 psi, 1/4 ID, 10 ft	1				
31	XTR704	GUN, XTR7, round handle, 4 finger RAC, 519	1				
32	162024	COUPLING; 3/8 m x f	2				
33✘	552069	LABEL, metalized	1				
35	258990	MANIFOLD, recirculation; see page 47	1				
36	258989	MANIFOLD, mix; see mix manifold manual 3A0590	1				
37	106212	SCREW, cap, hex hd; 3/8-16 x 2.5	2				
38	108063	GRIP, handle	2				
41	158683	FITTING, elbow, 90°; 1/2 st	2				
47	206995	FLUID, TSL, 1 qt.	1				
48	101566	NUT, lock; 3/8-16	2				
49▲	15U654	LABEL, A and B (set of 4)	1				

▲ Replacement Danger and Warning labels, tags, and cards are available at no cost.

✘ Not shown.

Parts Varying by Model with Hoppers

Ref.	Part	Description	XP70 Plural-Component Sprayer Models					
			571102	571152	571202	571252	571302	571402
4	571100	PUMP, fixed ratio, 1:1	1					
	571150	PUMP, fixed ratio, 1.5:1		1				
	571200	PUMP, fixed ratio, 2:1			1			
	571250	PUMP, fixed ratio, 2.5:1				1		
	571300	PUMP, fixed ratio, 3:1					1	
	571400	PUMP, fixed ratio, 4:1						1
18	100131	NUT, full hex; 3/8-16	7	7	7	7	7	7
55	24E872	BRACKET, hopper, painted	2	2	2	2	2	2
56	262479	HOPPER, blue	1	1	1	1	1	1
57	262480	HOPPER, green	1	1	1	1	1	1
60	H52506	HOSE, coupled, 5600 psi, 1.4 ID, 6 ft	2	2	2	2	2	2
61	16D376	FITTING, swivel, 1-1/4, mod, w/plug	2	2	2	2	2	2
62	111192	BOLT, flange hd; 3/8-16	4	4	4	4	4	4
64	113498	VALVE, relief, air, 110 psi	1		1	1	1	1
	116643	VALVE, relief, air, 90 psi		1				
65	262482	STRAINER, hopper, 7 gal- lon; 0.203 in. openings	2	2	2	2	2	2
66	124450	CLAMP, spring, con- stant-tension	1	1	1	1	1	1
67▲	15T468	LABEL, warning	2	2	2	2	2	2

Parts Varying by Model with No Hoppers

Ref.	Part	Description	XP70 Plural-Component Sprayer Models					
			571101	571151	571201	571251	571301	571401
4	571100	PUMP, fixed ratio, 1:1	1					
	571150	PUMP, fixed ratio, 1.5:1		1				
	571200	PUMP, fixed ratio, 2:1			1			
	571250	PUMP, fixed ratio, 2.5:1				1		
	571300	PUMP, fixed ratio, 3:1					1	
	571400	PUMP, fixed ratio, 4:1						1
18	100131	NUT, full hex	3	3	3	3	3	3
60	H52510	HOSE; 1/4 x 10 ft	2	2	2	2	2	2
64	113498	VALVE, relief, air, 110 psi	1		1	1	1	1
	116643	VALVE, relief, air, 90 psi		1				

Bare Proportioning Pump Package

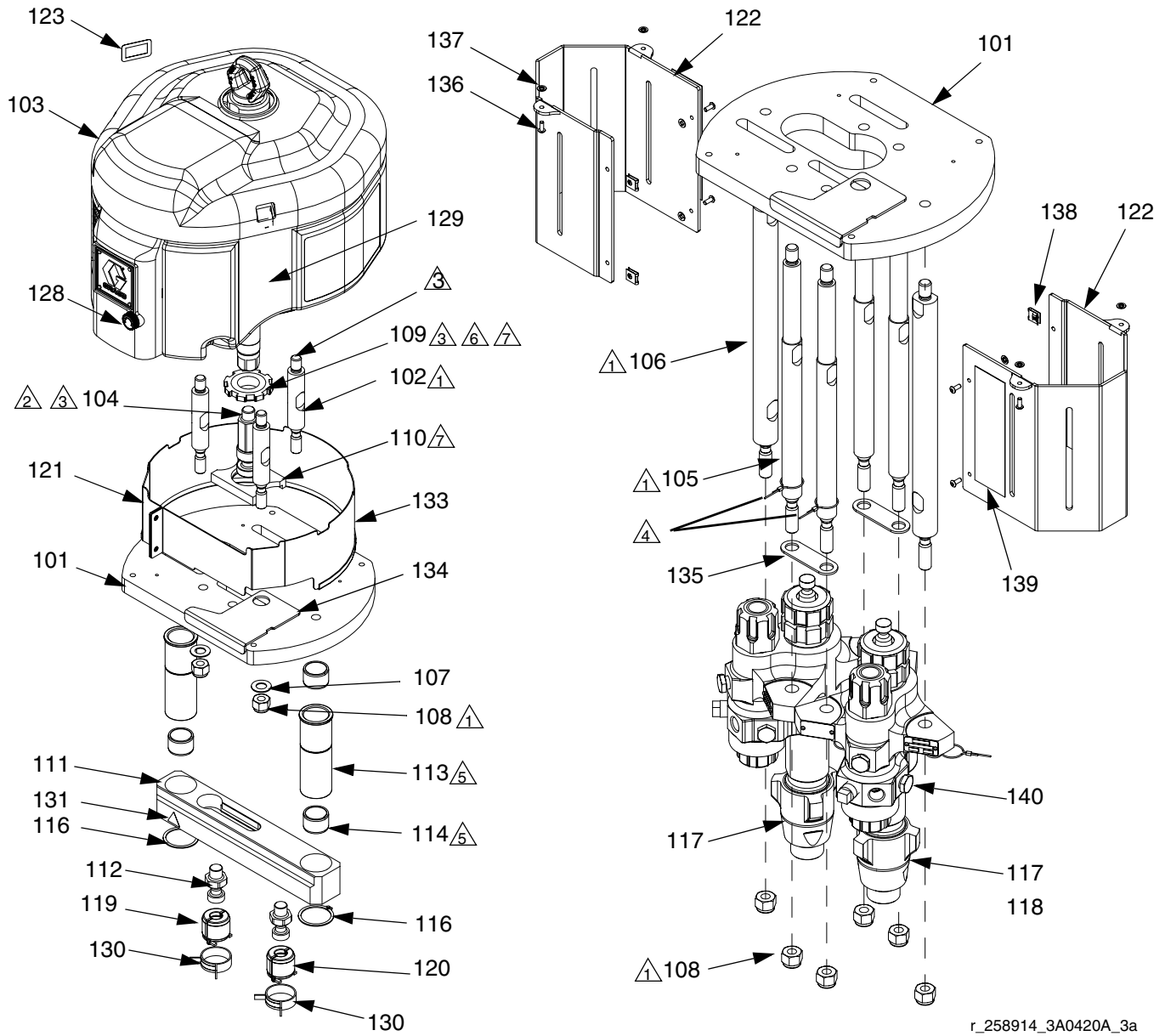

r_258914_3A0420A_2a

r_258914_3A0420A_3a

- ① Torque together to 50-60 ft-lbs (68-81 N•m).
- ② Torque to 145-155 ft-lbs (196-210 N•m).
- ③ Apply blue thread sealant.
- ④ Insert lanyard from locking pin onto pumps (17, 18) as shown.
- ⑤ Do not apply lubricant.
- ⑥ Torque to 70-80 ft-lbs (95-108 N•m).
- ⑦ Apply lithium grease to mating tapered surfaces.

Common Parts

Ref.	Part	Description	Qty.	Ref.	Part	Description	Qty.
101	262465	PLATE, motor	1	128	NXT102	KNOB, de-ice, 5 pack	1
102	262466	ROD, tie, 4.00 long, 1.00 dia	3	129	16D029	LABEL, XP70	1
103	N65DN0	MOTOR, 6500, de-icing, standard	1	130	124078	CLAMP, spring, constant-tension	2
104	262467	ROD, adapter	1	131▲	15H108	LABEL, pinch point	1
105	262468	ROD, tie, 14.25 long, w/shoulder	4	133	114225	TRIM, edge protection	2
106	262469	ROD, tie, 14.25 long, 1.25 dia	2	134	262475	BRACKET, ratio indicator	1
107	154636	WASHER, flat; 5/8	3	135	16E882	STRAP, lowers	2
108	101712	NUT, lock; 5/8-11	9	136		SCREW, cap, button hd; 10-32	8
109	16D451	NUT, yoke	1	137		WASHER, retaining, nylon	8
110	262470	BRACKET, ratio indicator	1	138	124665	NUT, captive; 10-32	4
111	262471	YOKE, pump assembly	1	139▲	15T468	LABEL, warning	2
112	15H392	ROD, adapter xtreme	2	141	206995	FLUID, tsl, 1 qt.	1
113	262472	SLEEVE, bearing	2	142	244524	WIRE, ground assembly with clamp	1
114	15C244	BEARING, sleeve	4				
116	123976	RING, snap, external	2				
121	262473	COVER, motor rod	1				
122	262474	COVER, pump	2				
123		LABEL, identification	1				

▲ Replacement Danger and Warning labels, tags, and cards are available at no cost.

Varying Parts

Ref.	Description	Ratio	1:1	1.5:1	2:1	2.5:1	3:1	4:1	Qty.
		Part	571100	571150	571200	571250	571300	571400	
117	A-Side pump (see manual 311762)	L085C0	L085C0	L085C0	L115C0	L14AC0	L14AC0	L14AC0	1
118	B-Side pump (see manual 311762)	L085C0	L058C0	L058C0	L058C0	L058C0	L048C0	L036C0	1
119†	A-Side coupler	247167	247167	247167	247167	244819	244819	244819	1
120†	B-Side coupler	247167	247167	247167	247167	247167	247167	247167	1
140❖	B-Side rupture disc		258962	258962	258962	258962	258962	258962	1

❖ Included with B-Side pump assembly.

† Included with new pump assemblies (117, 118).

Air Controls, 258983

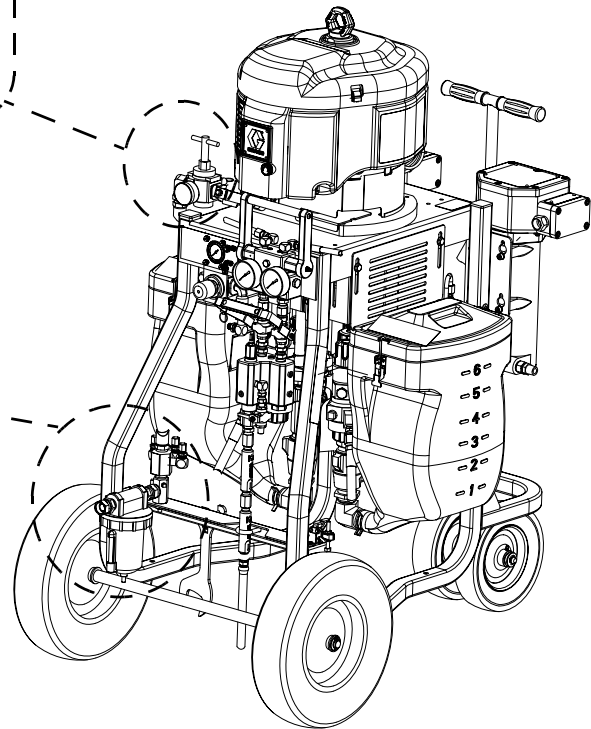
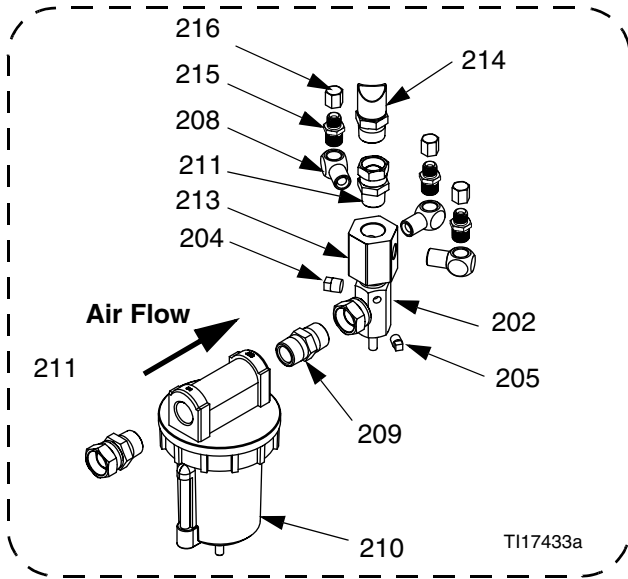
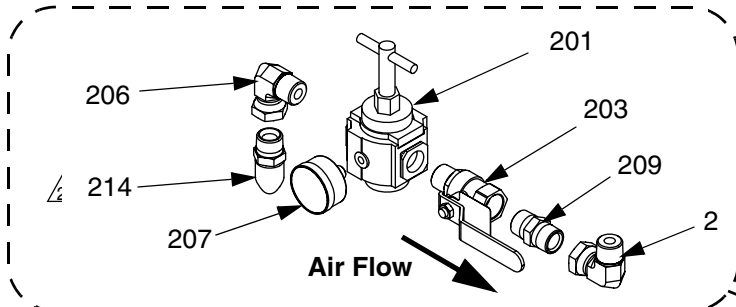

1. Apply anaerobic pipe sealant to all non-swiveling pipe threads.

2. Connect hose (214) to fitting (206) and air distribution manifold (213).

r_571100_3A0420A_1a-1

Ref. No.	Part No.	Description	Qty.
201	16F014	REGULATOR, air, t-handle	1
202	207675	MANIFOLD, air	1
203	113218	VALVE, ball	1
204	100509	PLUG; 1/4 npt	1
205	100403	PLUG; 1/8 npt	1
206	160327	FITTING, union, 90°; 3/4 m x f	2
207	101689	GAUGE, pressure, air	1
208	155699	FITTING, elbow, street; 3/8 npt	3
209	119992	FITTING, pipe, nipple, 3/4 x 3/4 npt	2
210	117628	FITLTER, air, auto drain; 3/4 npt	1
210a*	106204	ELEMENT, filter; 3/4 npt	1

Ref. No.	Part No.	Description	Qty.
211	157785	FITTING, union; 3/4 m x f	2
213	15E145	MANIFOLD, air distribution	1
214	16E004	HOSE, coupled, air; 26 in. (660.4 mm)	1
215	157350	NIPPLE; 3/8 x 1/4 npt	3
216	115781	CAP PLUG; 1/4 npt	3

* Not shown.

Fluid Manifold, 258990

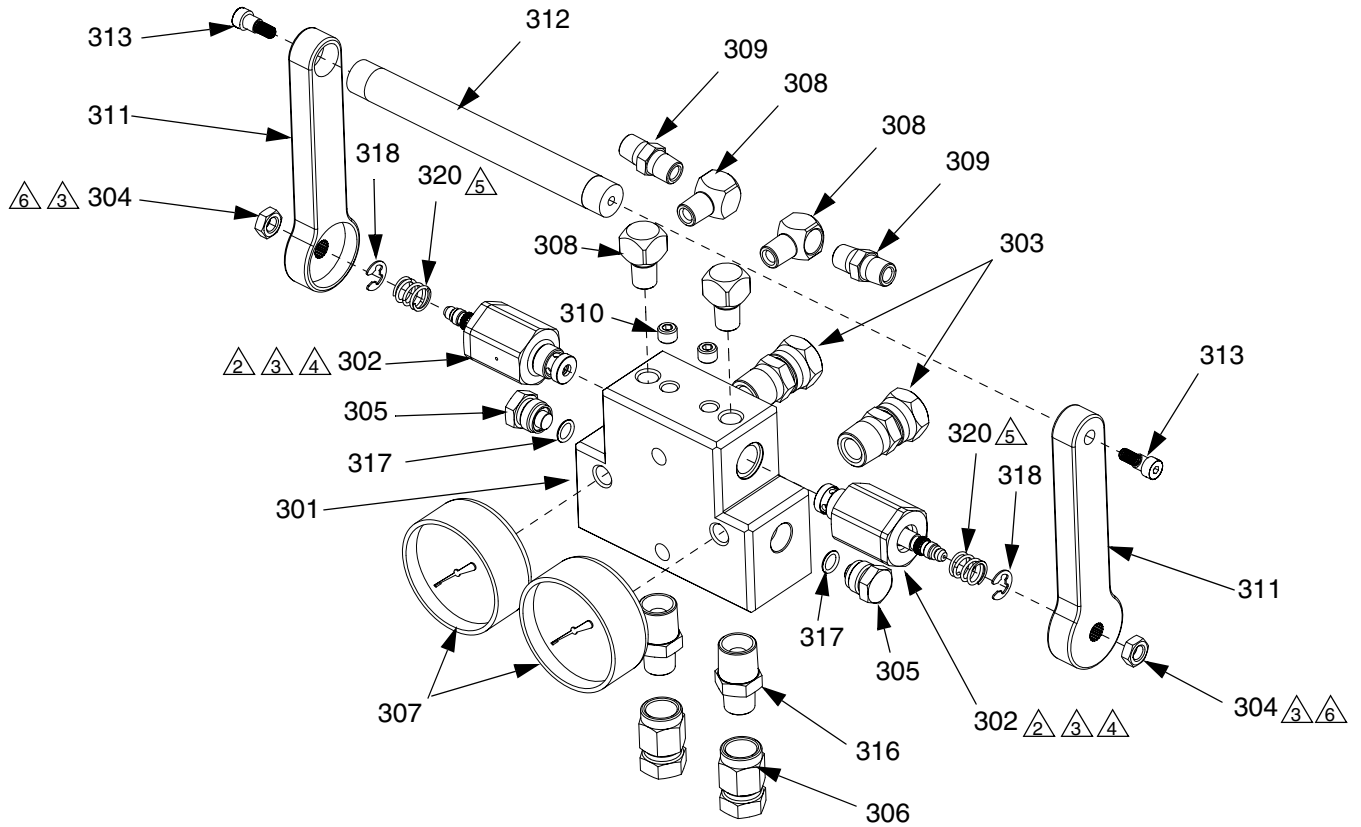

r_258988_3a0420a_1b

1. Apply anaerobic pipe sealant to all non-swiveling pipe threads.

2 Torque to 28-32 ft-lbs (38-43 N•m).

3 Apply blue anaerobic adhesive to threads.

4 Further tighten either valve (302) as required to line up handle straight across.

5 Apply grease to spring ends.

6 Torque to 70-90 in.-lbs (7.9-9 N•m).

Ref. No.	Part No.	Description	Qty.	Ref. No.	Part No.	Description	Qty.
301	16D693	BLOCK, manifold, recirculation	1	313	124859	SCREW, button hd	2
302	262520	VALVE, drain, cartridge	2	316	159239	FITTING, nipple; 1/2 x 3/8 npt	2
303	156684	UNION; 1/2 in. m x f	2	317	121399	O-RING, solvent resistant	2
304	112309	NUT, hex, jam	2	318	124676	RING, snap, external	2
305	198241	PLUG, port, pressure; 11/16-24	2	320	150829	SPRING, compression	2
306	156173	UNION, swivel; 3/8 fbe	2				
307	114434	GAUGE, pressure, fluid, sst; 10k psi	2				
308	100840	FITTING, elbow, street; 1/4 npt	4				
309	162453	FITTING, nipple; 1/4 npt x npsm	2				
310	557349	PLUG, dry seal 1/8 npt	2				
311	16E334	HANDLE, manifold	2				
312	16E332	ROD, connecting, handle	1				

Recommended Spare Parts

Keep these spare parts on hand to reduce downtime.

Pump Repair Kits

See page 11 to see what pumps are used on your sprayer model. See lower manual for repair kits.

Pump Filter O-rings (packs of 10)

262483, Top o-ring
244895, Middle o-ring
262484, Bottom o-ring

262520, Recirculation/Overpressure valve

15K692, Seal Mix Manifold Check Valve Cartridge

Mix Manifold Inlet Ball Valves

237917, Ball valve repair kit
248876, Spare valve (no handle)
237304, Spare valve (single handle)

248927, Spare Mix Elements (pack of 25)

248837, XTR7 Spray Gun Repair Kit

XHD010, Seat/Seal Kit for XHD RAC Tips (5 pack)

XHDxxx, spray tips

See spray gun manual for tips.

Pump Performance Charts

Calculate Fluid Outlet Pressure

To calculate fluid outlet pressure (psi/MPa/bar) at a specific fluid flow (gpm/lpm) and operating air pressure (psi/MPa/bar), use the following instructions and pump data charts.

1. Locate desired flow along bottom of chart.
2. Follow vertical line up to intersection with selected fluid outlet pressure curve. Follow left to scale to read fluid outlet pressure.

Calculate Pump Air Flow/Consumption

To calculate pump air flow/consumption (scfm or m³/min) at a specific fluid flow (gpm/lpm) and air pressure (psi/MPa/bar), use the following instructions and pump data charts.

1. Locate desired flow along bottom of chart.
2. Follow vertical line up to intersection with selected air flow/consumption curve. Follow right to scale to read air flow/consumption.

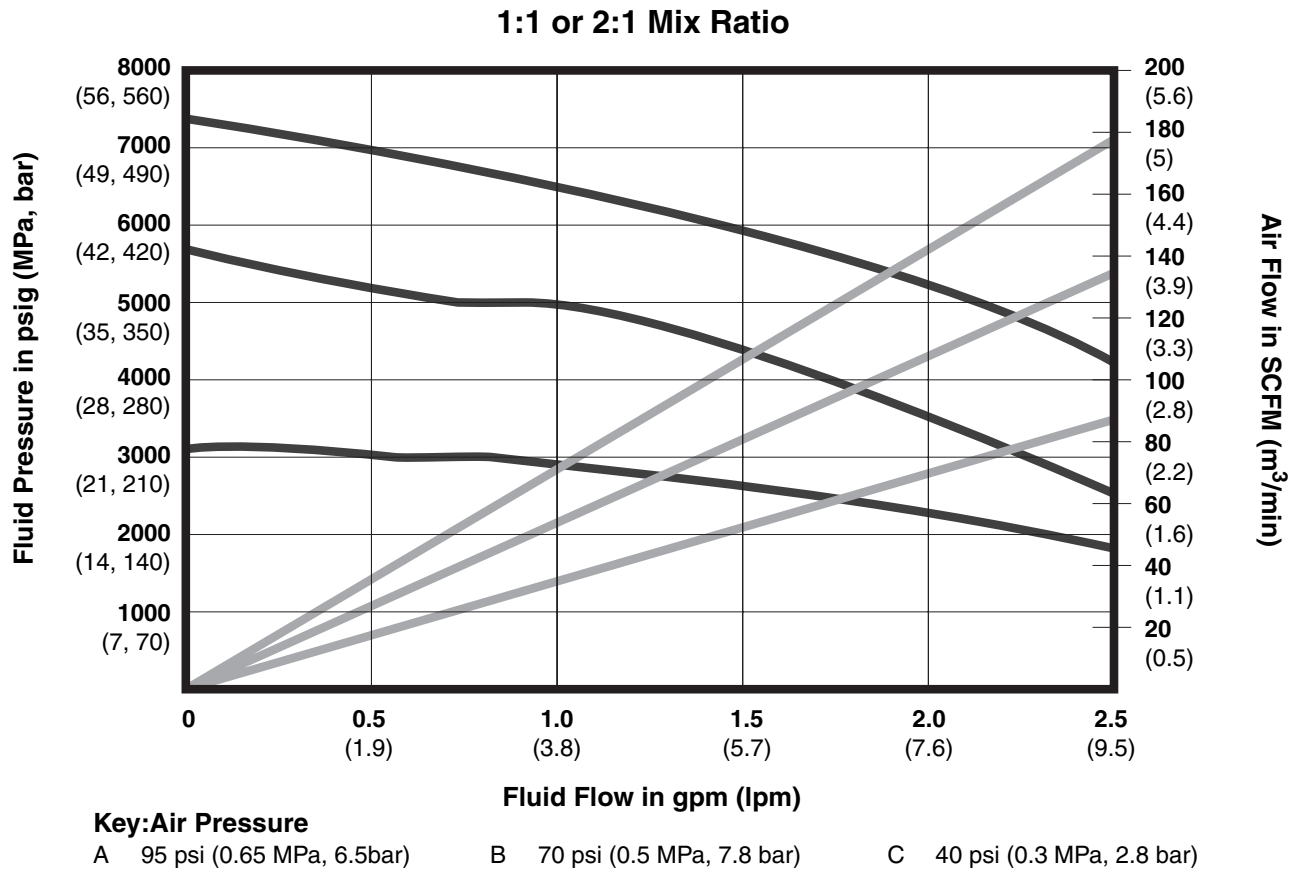

Pump Performance Charts Continued

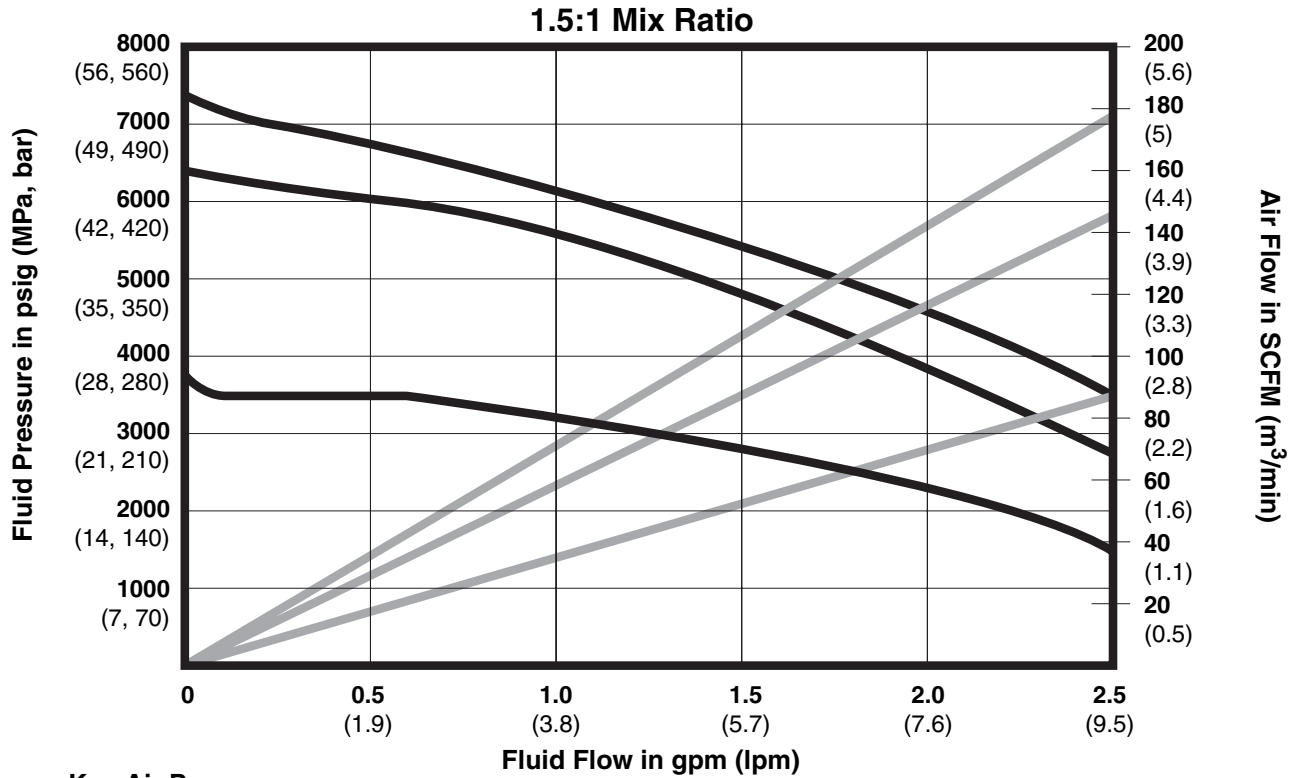

Key: Air Pressure

A 80 psi (0.55 MPa, 55 bar) B 70 psi (0.5 MPa, 7.8 bar) C 40 psi (0.3 MPa, 2.8 bar)

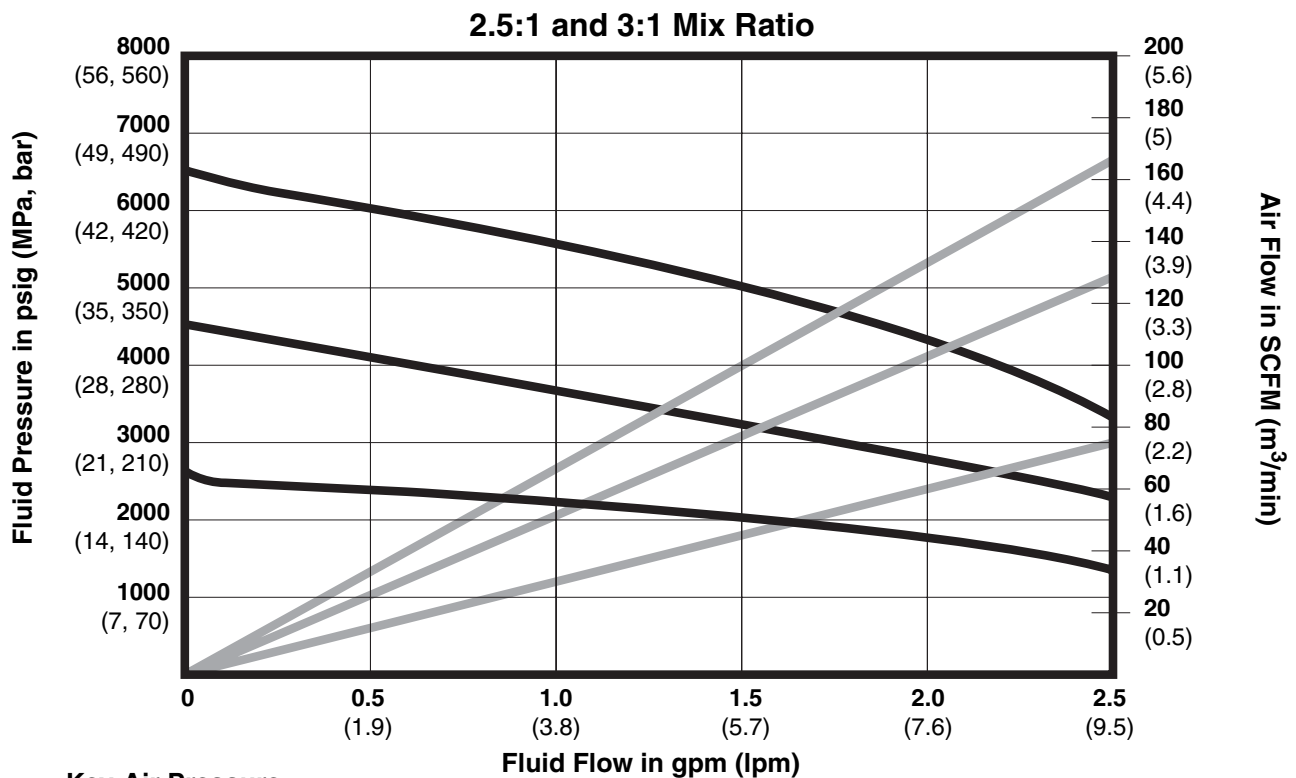

Key: Air Pressure

A 100 psi (0.7 MPa, 7 bar) B 70 psi (0.5 MPa, 7.8 bar) C 40 psi (0.3 MPa, 2.8 bar)

Pump Performance Charts Continued

4:1 Mix Ratio

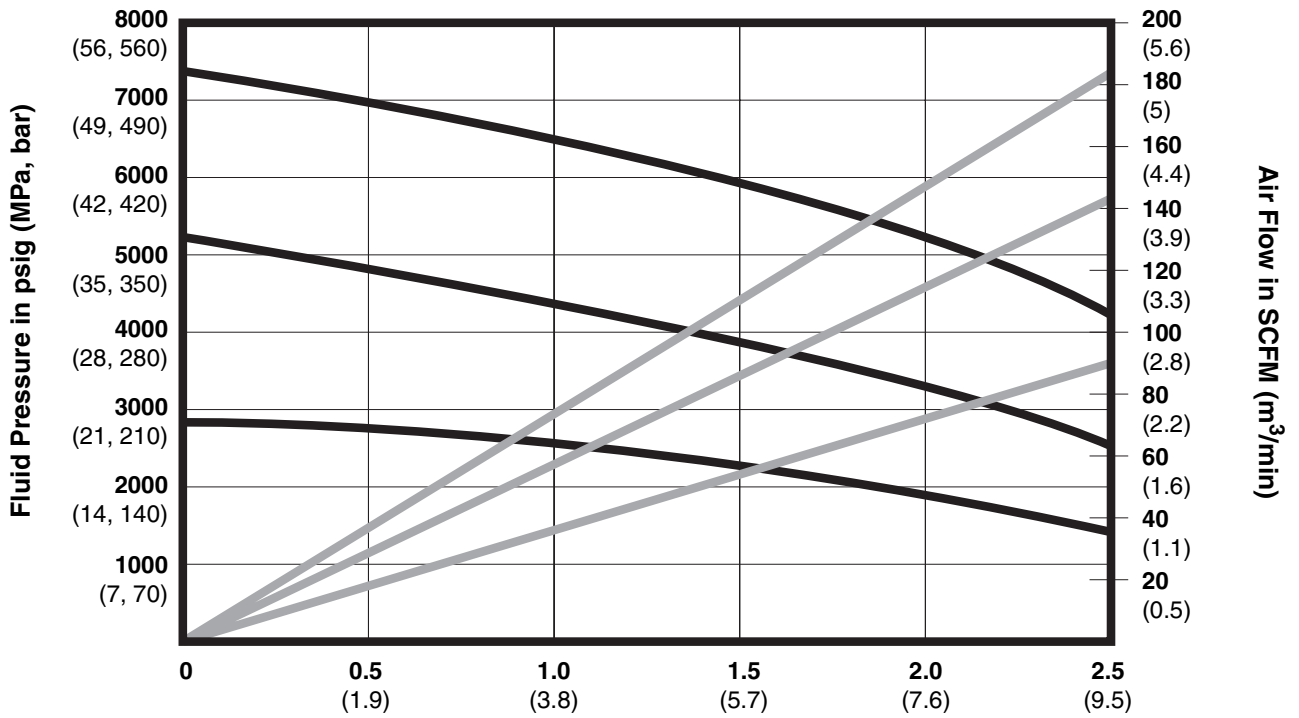

Key: Air Pressure

A 95 psi (0.65 MPa, 6.5bar)

B 70 psi (0.5 MPa, 7.8 bar)

C 40 psi (0.3 MPa, 2.8 bar)

Accessories and Kits

Acceptable For Use in Explosive Atmospheres

Blue 7 Gallon Hopper Kit, 24F376 Green 7 Gallon Hopper Kit, 24F377

Mount to the sides of an XP70 sprayer. See manual 406860 for more information.

Solvent Pump Kit, 262393

For supplying solvent to the mix manifold. See manual 310863 for more information.

Desiccant Dryer Kit, 262454

For use with polyurethane isocyanates in 7-gallon hoppers. See manual 406739 for more information.

Desiccant Dryer Filter 2 Pack, 24K984

Heater Adapter Kit, 262450

Hose and fittings for connecting Viscon HP heaters to XP70 sprayer. See manual 406861 for parts. Purchase heaters separately, see heater manual for part numbers.

Twistork Agitator Kit, 256274

For mixing viscous materials held within a 55-gallon drum. See manual 312769 for more information.

5:1 Feed Pump Kit, 256276

For supplying viscous materials from a drum to a XP70 sprayer. See manual 312769 for more information.

5:1 Drum Feed Kit, 256255

One 5:1 pump feed kit and one Twistork agitator kit for mixing and supplying viscous materials from a 55-gallon drum to a XP70 sprayer. See manual 312769 for more information.

10:1 Drum Feed Kit, 256433

For supplying highly viscous material from a 55-gallon drum to a XP70 sprayer. See manual 312769 for more information.

Remote Mix Manifold Carriage, 262522

A protective guard to mount mix manifold remote. See mix manifold manual for more information.

Gun Splitter, 234026

One splitter valve to use two spray guns with a proportioner. It can be used with one gun or two and provides for independent flushing of each gun while the other gun remains in use. See manual 309964 for more information.

DataTrak™ Conversion Kit, NXT606

Intrinsically safe battery operated NXT air motor accessory for material tracking system diagnostics and run-away control. See manual 311486 for more information.

Not Approved For Explosive Atmospheres

These kits do not carry the EX mark.

2:1 Feed Pump Kit, 256275

For supplying viscous materials from a drum to a XP70 sprayer. See manual 312769 for more information.

2:1 Drum Feed Kit, 256232

One T2 pump feed kit and one Twistork agitator kit for mixing and supplying viscous materials from a 55-gallon drum to a XP70 sprayer. See manual 312769 for more information.

Technical Data

Volume Mix Ratio	Pressure Ratio	“A” Side Pump	“B” Side Pump	Combined Fluid Output cc/cycle	Maximum Air Working Pressure psi (MPa, bar)	Maximum Fluid Working Pressure psi (MPa, psi)	Flow Rate at 40 cycles/min gpm (ltr/min)
1:1	76:1	Xtreme 85	Xtreme 85	173	95 (0.6, 6.5)	7250 (50, 500)	1.8 (6.9)
1.5:1	91:1	Xtreme 85	Xtreme 58	144	80 (0.5, 5.5)	7250 (50, 500)	1.5 (5.7)
2:1	76:1	Xtreme 115	Xtreme 58	174	95 (0.6, 6.5)	7250 (50, 500)	1.8 (6.9)
2.5:1	65:1	Xtreme 145	Xtreme 58	203	100 (0.7, 7)	6500, 45, 448)	2.1 (8.1)
3:1	68:1	Xtreme 145	Xtreme 48	193	100 (0.7, 7)	6800, 47, 469)	2.0 (7.7)
4:1	73:1	Xtreme 145	Xtreme 36	181	100 (0.7, 7)	7250 (50, 500)	1.9 (7.2)

Air inlet size	3/4 npsm(f)
Air consumption	75 cfm at 100 psi inlet/gpm 0.56 cu meter/min at 7 bar/liter/min
Maximum air pressure supply to the sprayer	175 psi (1 MPa, 12 bar)
Filtration:	
Air inlet filtration	40-micron filter/separator included
XP70 pump outlets	30 mesh
XTR7 Spray Gun.	60 mesh
Fluid pump inlets without hoppers.	1-1/4 in. npsm(m)
Fluid gauge manifold outlets	1/2 in. npt(f)
Fluid mix manifold inlets	3/8 in. npt(m) ball valves
Mix manifold material outlet	1/2 in. npt(f)
Maximum feed pressure from remote source	250 psi (1.7 MPa, 17 bar)
Fluid Viscosity Range:	
Gravity feed with 7 gallon (26 liter) hoppers	200 to 20,000 cps (pourable)
Pressure feed	Any viscosity that will not require feed pressure more than 15% of outlet pressure
Environmental Rating	Indoor/outdoor
Hazardous Areas	EX II 2 G c IIA T2
Ambient Temperature Range:	
Operating	40-130°F (4-54°C)
Storage	30-160°F (-1-71°C)
Maximum Fluid Temperature	160°F (71°C)
Sound pressure.	86 dBA at 100 psi (0.7 MPa, 7 bar)
Sound power.	98 dBA at 100 psi (0.7 MPa, 7 bar)
Wetted materials:	
Housings and manifolds	Carbon steel with electroless nickel plating
Miscellaneous parts	Plated carbon steel, stainless steels, carbide, acetal, UHM-WPE, nylon, PTFE solvent resistant plastics
Pump packings	Carbon filled PTFE
Flush pump suction tube.	Aluminum
Hoses	Nylon core
Weight:	
Full System with heaters, solvent flush pump, and hoppers	575 lbs (260 kg)
Bare system with no heaters, solvent flush pump, or hoppers	425 lbs (192 kg)
Maximum Storage Time:	5 years (To maintain original performance, replace soft seals after 5 years of inactivity.)
Maximum Lifetime:	Indefinite with recommended maintenance and periodic rebuilds for critical parts.
Power Efficiency Factor:	75 cu. ft compressed air/1 gallon sprayed material at 100 psi 0.56 m ³ compressed air /1 liter sprayed material at 0.7 MPa (7 bar)

Dimensions

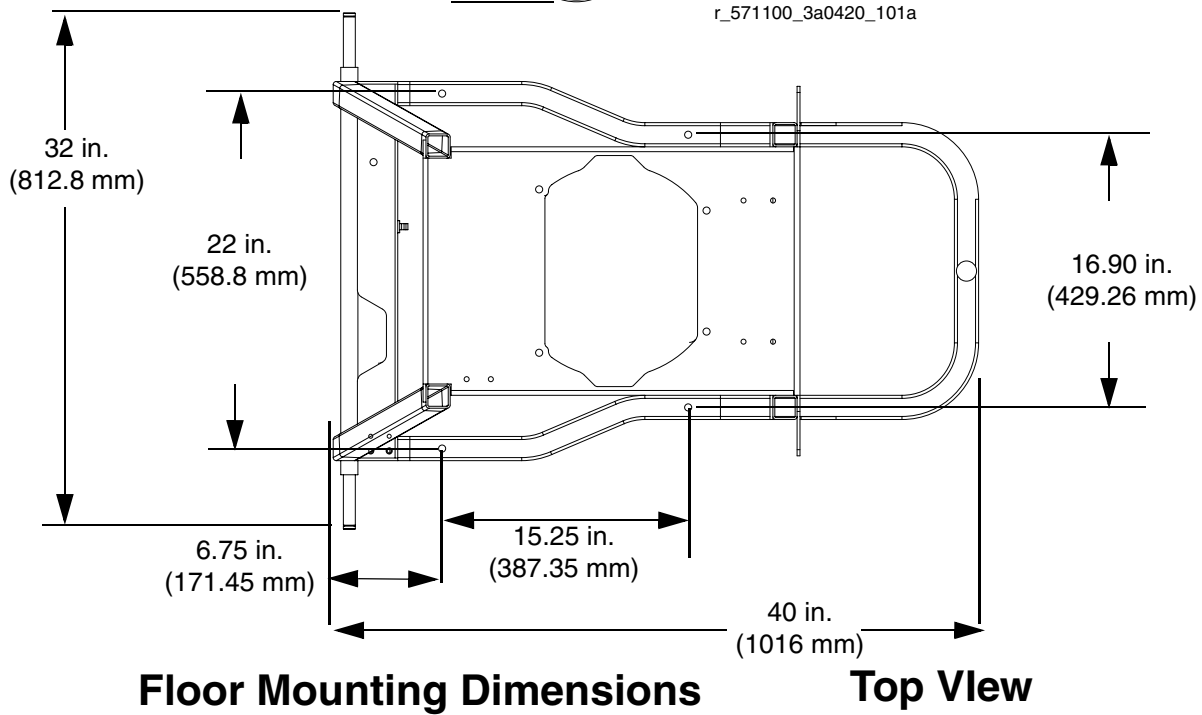
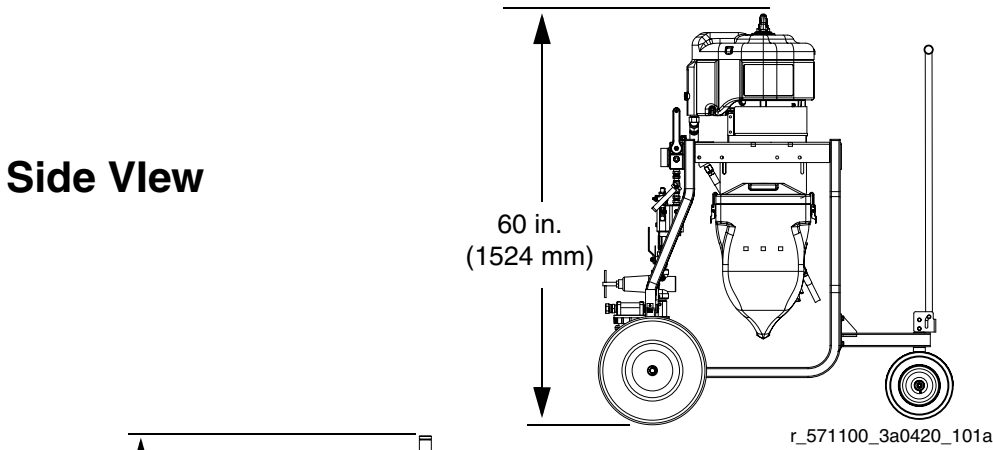
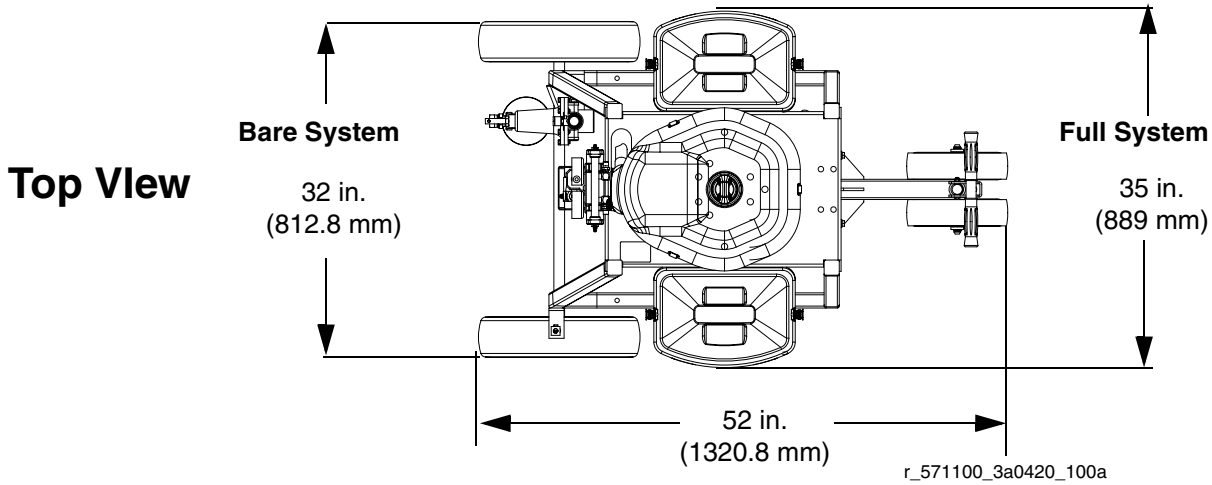

Graco Standard Warranty

Graco warrants all equipment referenced in this document which is manufactured by Graco and bearing its name to be free from defects in material and workmanship on the date of sale to the original purchaser for use. With the exception of any special, extended, or limited warranty published by Graco, Graco will, for a period of twelve months from the date of sale, repair or replace any part of the equipment determined by Graco to be defective. This warranty applies only when the equipment is installed, operated and maintained in accordance with Graco's written recommendations.

This warranty does not cover, and Graco shall not be liable for general wear and tear, or any malfunction, damage or wear caused by faulty installation, misapplication, abrasion, corrosion, inadequate or improper maintenance, negligence, accident, tampering, or substitution of non-Graco component parts. Nor shall Graco be liable for malfunction, damage or wear caused by the incompatibility of Graco equipment with structures, accessories, equipment or materials not supplied by Graco, or the improper design, manufacture, installation, operation or maintenance of structures, accessories, equipment or materials not supplied by Graco.

This warranty is conditioned upon the prepaid return of the equipment claimed to be defective to an authorized Graco distributor for verification of the claimed defect. If the claimed defect is verified, Graco will repair or replace free of charge any defective parts. The equipment will be returned to the original purchaser transportation prepaid. If inspection of the equipment does not disclose any defect in material or workmanship, repairs will be made at a reasonable charge, which charges may include the costs of parts, labor, and transportation.

THIS WARRANTY IS EXCLUSIVE, AND IS IN LIEU OF ANY OTHER WARRANTIES, EXPRESS OR IMPLIED, INCLUDING BUT NOT LIMITED TO WARRANTY OF MERCHANTABILITY OR WARRANTY OF FITNESS FOR A PARTICULAR PURPOSE.

Graco's sole obligation and buyer's sole remedy for any breach of warranty shall be as set forth above. The buyer agrees that no other remedy (including, but not limited to, incidental or consequential damages for lost profits, lost sales, injury to person or property, or any other incidental or consequential loss) shall be available. Any action for breach of warranty must be brought within two (2) years of the date of sale.

GRACO MAKES NO WARRANTY, AND DISCLAIMS ALL IMPLIED WARRANTIES OF MERCHANTABILITY AND FITNESS FOR A PARTICULAR PURPOSE, IN CONNECTION WITH ACCESSORIES, EQUIPMENT, MATERIALS OR COMPONENTS SOLD BUT NOT MANUFACTURED BY GRACO. These items sold, but not manufactured by Graco (such as electric motors, switches, hose, etc.), are subject to the warranty, if any, of their manufacturer. Graco will provide purchaser with reasonable assistance in making any claim for breach of these warranties.

In no event will Graco be liable for indirect, incidental, special or consequential damages resulting from Graco supplying equipment hereunder, or the furnishing, performance, or use of any products or other goods sold hereto, whether due to a breach of contract, breach of warranty, the negligence of Graco, or otherwise.

FOR GRACO CANADA CUSTOMERS

The Parties acknowledge that they have required that the present document, as well as all documents, notices and legal proceedings entered into, given or instituted pursuant hereto or relating directly or indirectly hereto, be drawn up in English. Les parties reconnaissent avoir convenu que la rédaction du présente document sera en Anglais, ainsi que tous documents, avis et procédures judiciaires exécutés, donnés ou intentés, à la suite de ou en rapport, directement ou indirectement, avec les procédures concernées.

Graco Information

For the latest information about Graco products, visit www.graco.com.

TO PLACE AN ORDER, contact your Graco distributor or call to identify the nearest distributor.

Phone: 612-623-6921 **or Toll Free:** 1-800-328-0211 **Fax:** 612-378-3505

*All written and visual data contained in this document reflects the latest product information available at the time of publication.
Graco reserves the right to make changes at any time without notice.*

Original instructions. This manual contains English. MM 3A0420

Graco Headquarters: Minneapolis

International Offices: Belgium, China, Japan, Korea

GRACO INC. AND SUBSIDIARIES • P.O. BOX 1441 • MINNEAPOLIS MN 55440-1441 • USA

Copyright 2010, Graco Inc. All Graco manufacturing locations are registered to ISO 9001.

www.graco.com
Revised 11/2011