

Instructions—Parts List



STAINLESS STEEL

30:1 Ratio President Pump

306769H

For airless and air-assisted spraying of finishing materials.

Model 206897, Series F

3600 psi (25.2 MPa, 252 bar) Maximum Working Pressure



Important Safety Instructions

**Read all warnings and instructions in this manual.
Save these instructions.**

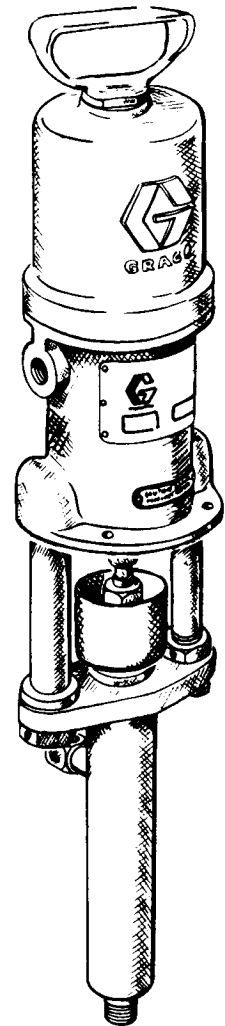

PROVEN QUALITY. LEADING TECHNOLOGY.

Table of Contents

Warnings	2
Installation	5
Operation	7
Troubleshooting	9
Service	10
Parts	12
Technical Data	14
Dimensions	15
Mounting Hole Layout	15
Warranty	16
Graco Information	16

Symbols

Warning Symbol



This symbol alerts you to the possibility of serious injury or death if you do not follow the corresponding instructions.

Caution Symbol



This symbol alerts you to the possibility of damage to or destruction of equipment if you do not follow the corresponding instructions.

WARNING



INSTRUCTIONS

EQUIPMENT MISUSE HAZARD

Equipment misuse can cause the equipment to rupture or malfunction and result in serious injury.

- Read all instruction manuals, tags, and labels before operating the equipment.
- Use the equipment only for its intended purpose. If you are not sure, contact your Graco distributor.
- Do not alter or modify this equipment.
- Check equipment daily. Repair or replace worn or damaged parts immediately.
- Do not exceed the maximum working pressure of the lowest rated system component. Refer to the **Technical Data** on page 14 for the maximum working pressure of this equipment.
- Use fluids and solvents which are compatible with the equipment wetted parts. Refer to the **Technical Data** section of all equipment manuals. Read the fluid and solvent manufacturer's warnings.
- Do not use hoses to pull equipment.
- Route hoses away from traffic areas, sharp edges, moving parts, and hot surfaces. Do not expose Graco hoses to temperatures above 82°C (180°F) or below -40°C (-40°F).
- Do not lift pressurized equipment.
- Wear hearing protection when operating this equipment.
- Comply with all applicable local, state, and national fire, electrical, and safety regulations.

WARNING

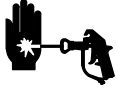

SKIN INJECTION HAZARD

Spray from the gun, leaks, or ruptured components can inject fluid into your body and cause extremely serious injury, including the need for amputation. Fluid splashed into the eyes or onto the skin can also cause serious injury.

- Fluid injected into the skin might look like just a cut, but it is a serious injury. **Get immediate surgical treatment.**
- Do not point the gun at anyone or at any part of the body.
- Do not put your hand or fingers over the spray tip.
- Do not stop or deflect leaks with your hand, body, glove or rag.
- Do not “blow back” fluid; this is not an air spray system.
- Always have the tip guard and the trigger guard on the gun when spraying.
- Check the gun diffuser operation weekly. Refer to the gun manual.
- Be sure the gun trigger safety operates before spraying.
- Lock the gun trigger safety when you stop spraying.
- Follow the **Pressure Relief Procedure** on page 7 if the spray tip clogs and before cleaning, checking, or servicing the equipment.
- Tighten all fluid connections before operating the equipment.
- Check the hoses, tubes, and couplings daily. Replace worn or damaged parts immediately. Do not repair high pressure couplings; you must replace the entire hose.
- Fluid hoses must have spring guards on both ends, to help protect them from rupture caused by kinks or bends near the couplings.



TOXIC FLUID HAZARD

Hazardous fluid or toxic fumes can cause serious injury or death if splashed into the eyes or onto the skin, inhaled, or swallowed.

- Know the specific hazards of the fluid you are using.
- Store hazardous fluid in an approved container. Dispose of hazardous fluid according to all local, state, and national guidelines.
- Always wear protective eyewear, gloves, clothing, and a respirator as recommended by the fluid and solvent manufacturer.

WARNING



FIRE AND EXPLOSION HAZARD

Improper grounding, poor ventilation, open flames, or sparks can cause a hazardous condition and result in a fire or explosion and serious injury.

- Ground the equipment and the object being sprayed. Refer to **Grounding** on page 5.
- If there is any static sparking or you feel an electric shock while using this equipment, **stop spraying immediately**. Do not use the equipment until you identify and correct the problem.
- Provide fresh air ventilation to avoid the buildup of flammable fumes from solvents or the fluid being sprayed.
- Keep the spray area free of debris, including solvent, rags, and gasoline.
- Electrically disconnect all equipment in the spray area.
- Extinguish all open flames or pilot lights in the spray area.
- Do not smoke in the spray area.
- Do not turn on or off any light switch in the spray area while operating or if fumes are present.
- Do not operate a gasoline engine in the spray area.



MOVING PARTS HAZARD

Moving parts, such as the air motor piston, can pinch or amputate your fingers.

- Keep clear of all moving parts when starting or operating the pump.
- Before servicing the equipment, follow the **Pressure Relief Procedure** on page 7 to prevent the equipment from starting unexpectedly.

Installation

NOTE: Reference numbers and letters in parentheses refer to callouts in the figures and parts drawing.

Mount the pump to suit the type of installation planned. The pump dimensions and mounting hole layout are shown on page 15.

Grounding

⚠ WARNING



FIRE AND EXPLOSION HAZARD
Before operating the pump, ground the system as explained below. Also read the section **FIRE AND EXPLOSION HAZARD** on page 4.

- *Air and fluid hoses:* Use only electrically conductive hoses with 500 ft (150 m) maximum combined hose length to ensure grounding continuity.
 - *Air compressor:* Follow manufacturer's recommendations.
 - *Spray gun or dispensing valve:* Connect to a properly grounded fluid hose and pump.
 - *Object being sprayed:* Follow your local code.
 - *Fluid supply container:* Follow your local code.
 - *Solvent pails used when flushing:* Follow your local code. Use only metal pails, which are conductive, placed on a grounded surface. Do not place the pail on a nonconductive surface, such as paper or cardboard, which interrupts the grounding continuity.
 - *To maintain proper grounding continuity when flushing or relieving pressure,* always hold the metal part of the spray gun firmly to the side of a grounded metal pail, then trigger the gun.
- *Pump:* Use the ground wire and clamp. See Fig. 1. Loosen the grounding lug locknut (W) and washer (X). Insert one end of the ground wire (Y) into the slot in the lug (Z), and tighten the locknut securely. Connect the other end of the wire to a true earth ground. Order Part No. 237569, Ground Wire and Clamp.

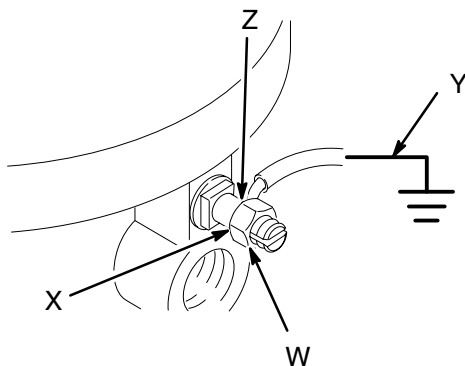

0720

Fig. 1

Installation

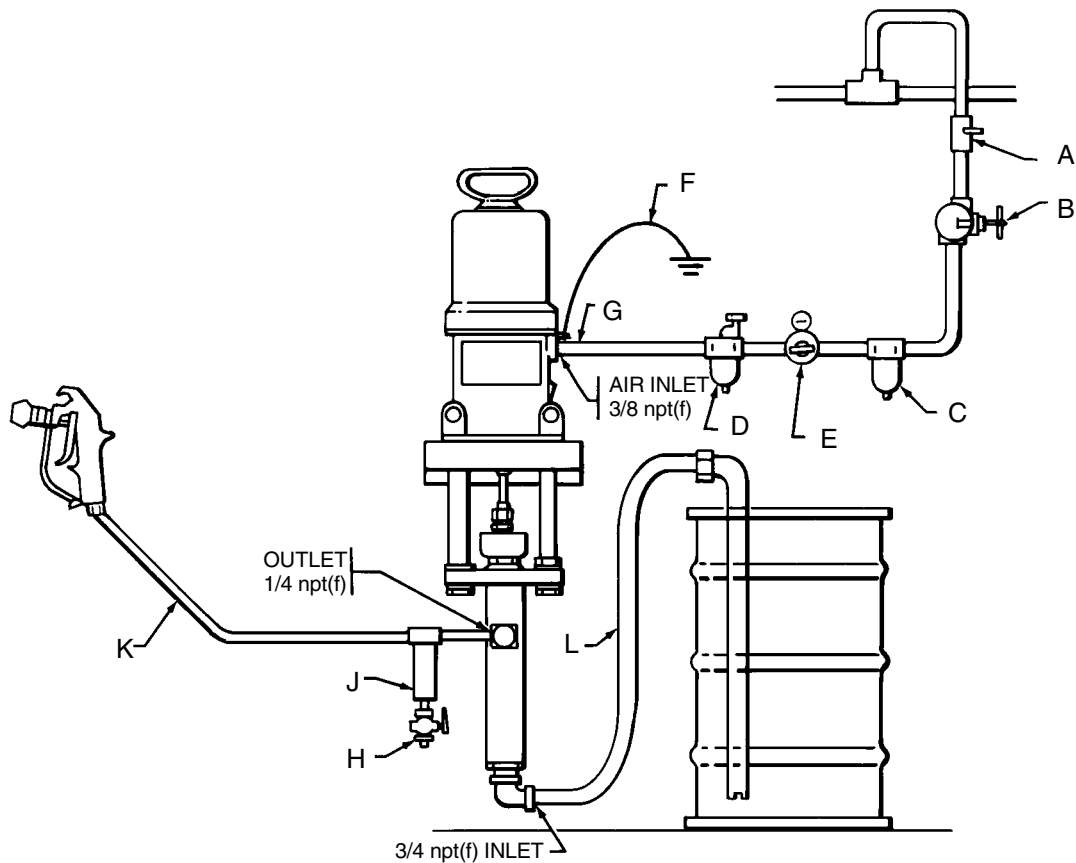

8000

NOTE: The Typical Installation shown above is only a guide to selecting and installing required and optional accessories. For assistance in designing a system to suit your needs, contact your Graco representative.

⚠ WARNING

Two accessories are required in your system; a bleed-type master air valve (A) and a fluid drain valve (H). These accessories help reduce the risk of serious injury including injection, splashing in the eyes, and injury from moving parts if you are adjusting or repairing the pump.

The bleed-type master air valve relieves air trapped between this valve and the pump after the air regulator is shut off. Trapped air can cause the pump to cycle unexpectedly. Locate the valve close to the pump.

The fluid drain valve assists in relieving fluid pressure in the displacement pump, hose, and gun; triggering the gun to relieve pressure may not be sufficient.

Connect a suction hose or siphon tube (L) to the 3/4 npt(f) intake of the pump.

Install the air line accessories in the approximate order shown in the **Typical Installation**. Install the bleed-type master air valve (A) within easy reach of the pump. A pump runaway valve (B) installed on the air line senses when the pump is running too fast and shuts off the air supply to the motor. An air filter (C) removes harmful dirt and moisture from your compressed air supply. For automatic air motor lubrication, install an air line lubricator (D) close to the pump air inlet. Install an air regulator (E) to control air to the motor and pump speed.

Be sure the air supply hose is properly grounded, and is at least 1/2 in. (13 mm) ID in order to supply an adequate volume of air to the motor.

On the fluid line, install a drain valve (H) close to the fluid outlet to assist in relieving fluid pressure and a fluid filter (J) to help prevent tip clogging. Connect a suitable, electrically conductive fluid hose and spray gun to the pump's 1/4 in. npt outlet.

Operation

Pressure Relief Procedure

⚠ WARNING

 **PRESSURIZED EQUIPMENT HAZARD**

The system pressure must be manually relieved to prevent the system from starting or spraying accidentally. To reduce the risk of an injury from accidental spray from the gun, splashing fluid, or moving parts, follow the **Pressure Relief Procedure** whenever you:

- are instructed to relieve the pressure,
- stop spraying,
- check or service any of the system equipment,
- or install or clean the spray tip/nozzle.

1. Lock the gun/valve trigger safety.
2. Close the pump air regulator.
3. Close the master bleed-type air valve (required in your system).

4. Unlock the gun/valve trigger safety.
5. Hold a metal part of the gun/valve firmly to a grounded metal waste container and trigger to relieve the fluid pressure.
6. Lock the gun/valve trigger safety.
7. Open the pump drain valve (required in your system), having a container ready to catch the drainage.
8. Leave the drain valve open until you are ready to spray again.

If you suspect that the spray tip or hose is completely clogged, or that pressure has not been fully relieved after following the steps above, slowly loosen the tip guard retaining nut or hose end coupling and relieve pressure gradually, then loosen it completely. Then clear the tip or hose.

Operation

WARNING

Never operate the pump with the air motor plates removed. Moving parts in the air motor can pinch or amputate fingers.

WARNING

To reduce the risk of serious injury whenever you are instructed to relieve pressure, always follow the **Pressure Relief Procedure** on page 7.

The pump was tested in oil, and some oil was left in the pump. If the oil will contaminate the fluid you are pumping, flush it out.

Fill the packing nut/wet-cup 1/2 full with Graco Throat Seal Liquid or a compatible solvent. Keep the cup filled at all times to help prevent the fluid you are pumping from drying on the displacement rod and damaging the throat packings.

To start the pump, turn on the main air supply. Open the bleed-type master air valve (A). Open the (last) spray gun. Slowly open the air regulator until the pump is running smoothly (about 40 psi (280 kPa, 2.8 bar)]. Operate the pump until all air is purged from the system. Release the gun trigger and engage the gun safety latch.

Use the air regulator (F) to control fluid pressure and pump speed. Always use the lowest pressure necessary to get the desired results. Higher pressures cause premature pump wear and spray tip wear, and usually do not improve the spray pattern.

WARNING

To reduce the risk of overpressurizing your system, which could result in component rupture and cause serious injury, never exceed 120 psi (840 kPa, 8.4 bar) Maximum Incoming Air Pressure to the pump.

In a direct supply system, with adequate air pressure supplied to the motor, the pump starts when the gun or dispensing valve is opened, and stalls against pressure when it is closed.

If the pump accelerates quickly or is running too fast, stop it immediately. Check the fluid supply and refill it if necessary. Prime the pump to remove all air from the system, or flush the pump and **relieve the pressure**.

NOTE: A pump runaway valve (B) can be installed on the air line to automatically shut off the pump if it starts to run too fast.

Shutdown and Care of the Pump

Always stop the pump at the bottom of its stroke to prevent fluid from drying on the rod and damaging the throat packings.

If you are pumping fluid which dries, hardens, or sets up, flush the system with a compatible solvent as often as necessary to prevent a buildup of dried fluid in the pump or hoses.

Check the tightness of the packing nut weekly. It should be tight enough to stop leakage, but no tighter. Always **relieve the pressure** before adjusting the packing nut.

Flushing

To reduce the risk of injection injury, static sparking, or splashing, **relieve the pressure** and remove the spray tip before flushing. Hold a metal part of the gun/valve firmly to the side of a grounded metal pail and use the lowest possible fluid pressure during flushing.

Troubleshooting



WARNING

To reduce the risk of serious injury whenever you are instructed to relieve pressure, always follow the **Pressure Relief Procedure** on page 7.

NOTE: Check all possible problems and solutions before disassembling the pump.

NOTE: Before servicing this equipment, always make sure to **relieve the pressure**.

PROBLEM	CAUSE	SOLUTION
Pump does not operate, or no fluid flow	Loose or broken pump parts	Disassemble, check, repair.
	Restricted line or inadequate air supply	Clear, increase.
	Exhausted fluid supply	Refill and prime.
	Clogged fluid hoses	Clean, or replace.
	Held open or worn piston or intake valve	Repair. See page 10.
	Damaged air motor	Repair; see manual 306982.
Pump operates, but output is low	Insufficient air supply	Increase.
	Exhausted fluid supply	Refill and prime.
	Obstructed gun or dispensing valve	Clear.
	Damaged fluid pump packings	Replace.
	Held open or worn piston or intake valve	Repair. See page 10.
Erratic or accelerated operation	Exhausted fluid supply	Refill and prime.
	Fluid intake or piston valve worn.	Repair; see manual 307719.

Service

⚠ WARNING

To reduce the risk of serious injury whenever you are instructed to relieve pressure, always follow the **Pressure Relief Procedure** on page 7.

Before you start

- Have all necessary parts on hand. Recommended spare parts are shown in the parts list, for example, (113*). A packing repair kit is not available.
- For best results, always replace the glands when replacing the packings.
- Use a compatible solvent to clean parts. Inspect for wear or damage and replace parts as needed. Scoring or irregular surfaces on the displacement rod (108) or polished inlet wall of the sleeve (107) causes premature packing wear and leaking. Check these parts by rubbing a finger on the surface and by holding the parts up to the light at a slight angle.
- Use light, water-proof grease wherever lubrication is indicated.

Disassembly (See Figs. 2, 3, and 4)

1. Flush the pump, if possible. **Relieve the pressure.** Disconnect all air and fluid hoses. Remove the pump from its mounting and clamp it in a vise.
2. Unscrew the coupling (115) from the bushing (114). Loosen the locknut setscrews (6) and unscrew the locknuts (11) from the mounting tubes (2, 3). Do not lose the nylon pellets (9) in the locknuts. Pull the pump off the mounting tubes.

⚠ CAUTION

If replacing the mounting tubes (2, 3), wrench them close to the air motor base during disassembly and reassembly to prevent damaging the threads in the air motor base. Also, lubricate the threads.

3. Clamp the displacement pump in a vise. Place a wrench on the flats of the intake valve body (121) and unscrew it. Remove all intake valve parts.

4. Unscrew the coupling bushing (114) from the displacement rod (108). Loosen the packing nut (120). Push the rod down as far as possible and grasp the piston flats to pull the rod assembly out.
5. Unscrew the piston (119) and remove all packings, ball, and glands.
6. Remove the packing nut (120), packings, and glands from the pump housing (118) throat.
7. Clean and inspect all parts. If the sleeve (107) does not come out with the rod, inspect it in place. If you must remove the sleeve, and it does not come out easily, contact your Graco representative. Install the new sleeve with the tapered end down.

NOTE: The seats in the intake (121) and piston (119) bodies are hard carbide. Do not attempt to reseat the balls as that will chip the seat.

⚠ CAUTION – Wrench upper ends of tubes if removing from air motor.

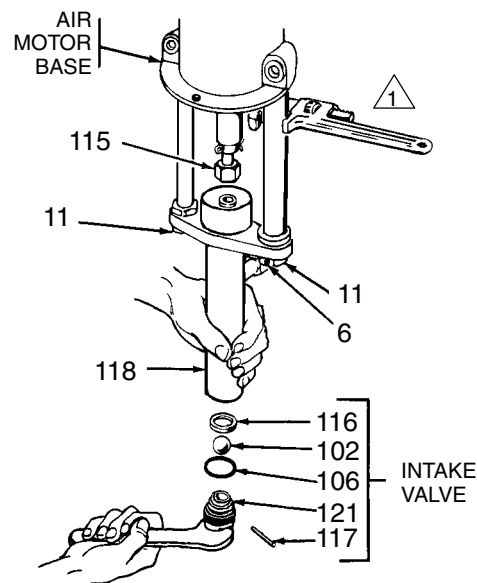

8001

Fig. 2

Service

Reassembly (See Figs. 2, 3, and 4)

1. Lubricate all parts.
2. One at a time, install these parts in the throat of the pump housing (118): one male gland (112), four PTFE v-packings (105) with the lips of the packings facing down, and one female gland (111). Loosely install the packing nut (120).
3. One at a time, install these parts on the piston body (119): one backup washer (110), one female gland (111), four PTFE v-packings (105) with the lips of the packings facing up, one male gland (112) and one retainer (113).

NOTE: Before installing piston in displacement rod, measure from the bottom of the backup washer (110) to the top of the packing retainer (113). If dimension is less than 1.02 in. (25.9 mm), place up to 3 shims (129) between the female gland (111) and backup washer (110) to achieve required dimension.

4. Place the ball (103) on the piston. Screw the piston into the displacement rod, torque to 65–75 ft-lb (88–102 N•m). If they were removed, reinstall the ball stop pin (109) and cotter pins (101).
5. With the sleeve (107) and gasket (104) installed, grease the displacement rod and carefully guide it through the pump housing and throat packings.
6. Screw the bushing (114) onto the rod (108).
7. Reinstall the intake valve assembly.
8. Securely clamp the air motor upside-down in a vise.
9. Butt the connecting rod (10) and bushing (114) together and move the displacement pump until the mounting tubes align. Leave the coupling nut (115) loose. Install and tighten a locknut (11) on the large mounting tube (2) first. Install a locknut (11) on the other tube, without altering the alignment. Tighten the coupling nut (115). Do not tighten the locknut setscrews (6) yet.

10. Apply low air pressure (about 40 psi (280 kPa, 2.8 bar) to the motor. Adjust the locknut on the small mounting tube (3) until the pump is running smoothly. Reduce the air pressure and adjust the nuts as necessary until the pump runs smoothly at 15 psi (104 kPa, 1 bar) air or less. Now tighten the nuts securely, and with the nylon pellets (9) in place, tighten the setscrews.
11. Remount the pump and connect the ground wire.

- △ 1 See NOTE at left for piston packing stack dimension requirements.
- △ 2 Lips of piston v-packings must face up.
- △ 3 Lips of throat v-packings must face down.

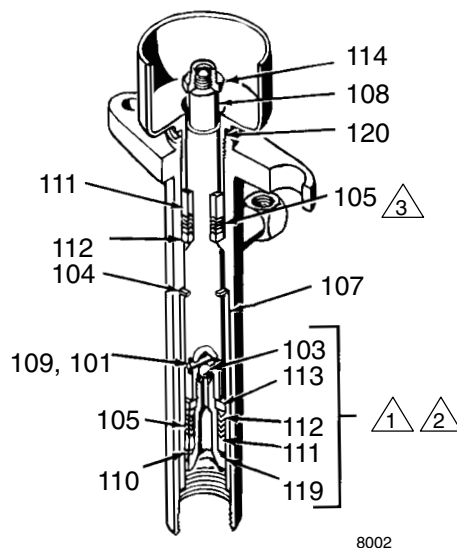

Fig. 3

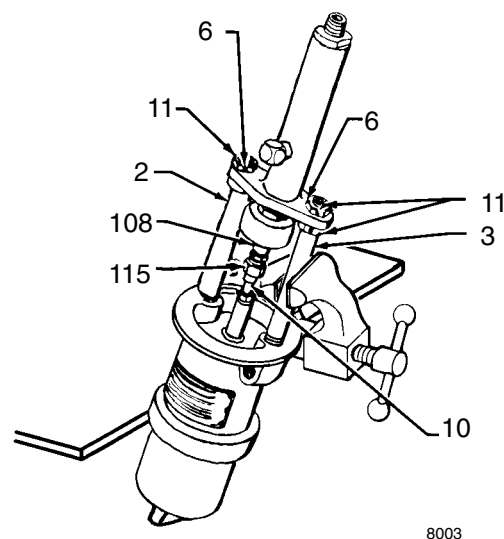
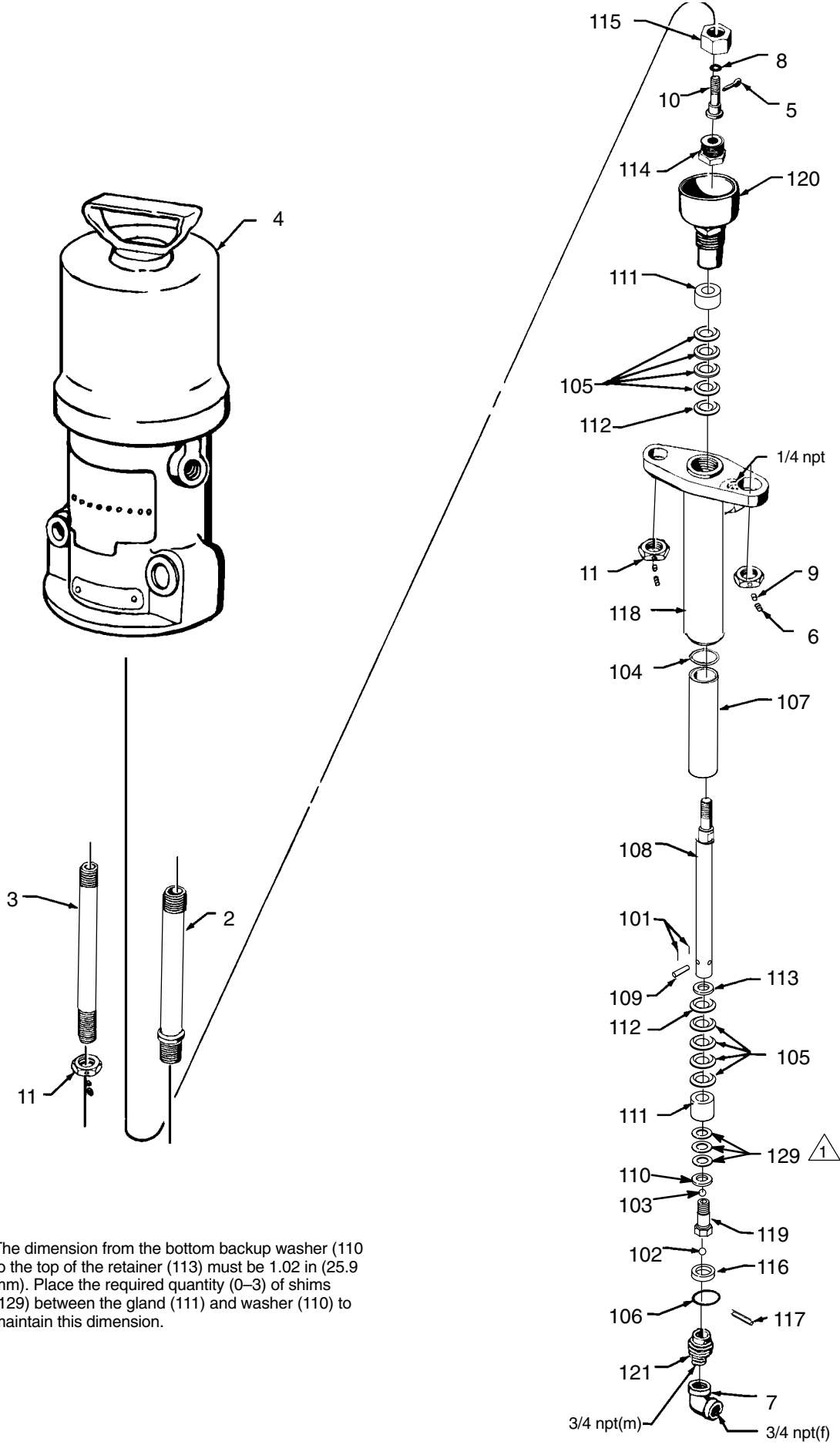

Fig. 4

Parts



1 The dimension from the bottom backup washer (110) to the top of the retainer (113) must be 1.02 in (25.9 mm). Place the required quantity (0-3) of shims (129) between the gland (111) and washer (110) to maintain this dimension.

Parts

Model 206897

30:1 President Pump, Series F

Includes items 1–11

Ref. No.	Part No.	Description	Qty.
1	206184	DISPLACEMENT PUMP See parts list at right	1
2	206195	MOUNTING TUBE, return; 1" OD	1
3	206196	MOUNTING TUBE, supply; 3/4" OD	1
4	205038	AIR MOTOR See manual 306982	1
5*	100579	PIN, cotter; 7/64" dia.; 1" long	1
6	102120	SETSCREW, soc hd; No. 10–24; 3/16" long	3
7	102325	ELBOW, 90°; 3/4 npt(f)	1
8*	156082	O-RING, nitrile rubber	1
9	160519	PELLET, nylon, mounting tube locknut	3
10	165620	ROD, connecting	1
11	165623	NUT, special lock; 3/4" garden hose thread	3

* Recommended tool box spare parts. Keep on hand to reduce down time.

Ref. No. 1

Displacement Pump

Includes items 101–129

Ref. No.	Part No.	Description	Qty.
101*	100063	PIN, cotter; 1/16" dia.; 1" lg	2
102*	101750	BALL, sst; 1/2" dia.; intake	1
103*	102119	BALL, sst; 5/16" dia.; piston	1
104*	164480	GASKET, sleeve; PTFE	1
105*	164862	V-PACKING, PTFE	8
106*	165052	O-RING, PTFE	1
107*	24C500	SLEEVE	1
108*	165609	ROD, displacement	1
109*	165610	PIN, ball stop	1
110*	165611	WASHER, packing backup	1
111*	165612	GLAND, female, PTFE	2
112*	165613	GLAND, male	2
113*	165614	RETAINER, packing	1
114	165615	BUSHING, coupling	1
115	165616	NUT, coupling	1
116	165617	RETAINER, o-ring	1
117	165618	PIN, ball stop	1
118	206186	HOUSING, pump	1
119	206187	BODY, piston	1
120	206188	NUT, packing	1
121	223593	BODY, intake valve	1
129	112425	SHIM	3

* Recommended tool box spare parts. Keep on hand to reduce down time.

Technical Data

Category	Data
Maximum working pressure	3600 psi (25.2 MPa, 252 bar)
Fluid pressure ratio	30:1
Air pressure operating range	40–120 psi (280–480 kPa, 2.8–8.4 bar)
Delivery	1 gpm (4 lpm)
Maximum recommended pump speed	60 cycles per minute
Cycles per gallon (liter)	62 (16)
Air motor effective diameter	4.25" (108 mm)
Stroke	4" (102 mm)
Air consumption	Approx. 28 cfm (0.79 m ³ /min) at 1 gpm (3.8 lpm) at 70 psi (480 kPa, 5 bar)
Wetted parts	316 stainless steel, PTFE, tungsten carbide
Weight	31 lb (14 kg)

Dimensions

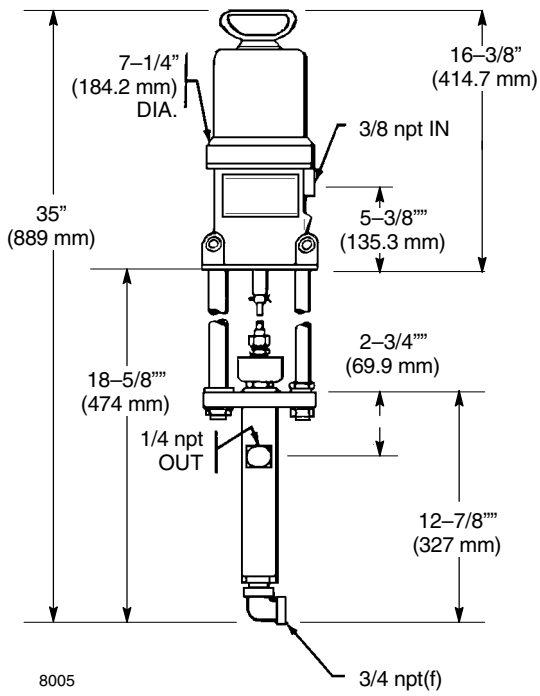

Mounting Hole Layout

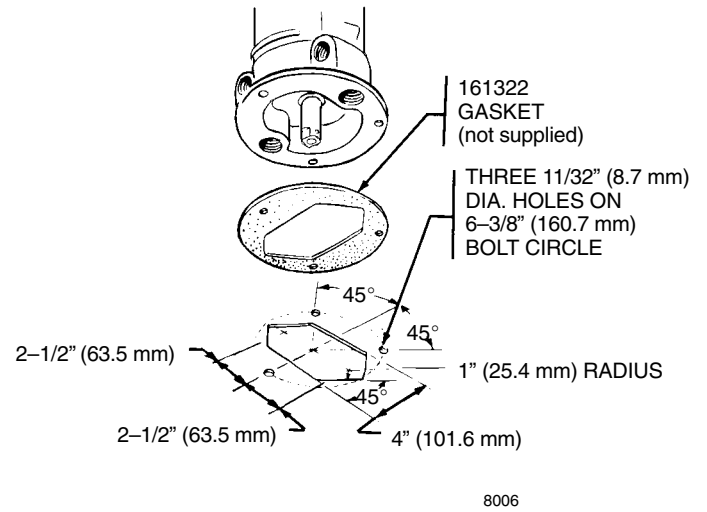

Graco Standard Warranty

Graco warrants all equipment manufactured by Graco and bearing its name to be free from defects in material and workmanship on the date of sale by an authorized Graco distributor to the original purchaser for use. With the exception of any special, extended, or limited warranty published by Graco, Graco will, for a period of twelve months from the date of sale, repair or replace any part of the equipment determined by Graco to be defective. This warranty applies only when the equipment is installed, operated and maintained in accordance with Graco's written recommendations.

This warranty does not cover, and Graco shall not be liable for general wear and tear, or any malfunction, damage or wear caused by faulty installation, misapplication, abrasion, corrosion, inadequate or improper maintenance, negligence, accident, tampering, or substitution of non-Graco component parts. Nor shall Graco be liable for malfunction, damage or wear caused by the incompatibility of Graco equipment with structures, accessories, equipment or materials not supplied by Graco, or the improper design, manufacture, installation, operation or maintenance of structures, accessories, equipment or materials not supplied by Graco.

This warranty is conditioned upon the prepaid return of the equipment claimed to be defective to an authorized Graco distributor for verification of the claimed defect. If the claimed defect is verified, Graco will repair or replace free of charge any defective parts. The equipment will be returned to the original purchaser transportation prepaid. If inspection of the equipment does not disclose any defect in material or workmanship, repairs will be made at a reasonable charge, which charges may include the costs of parts, labor, and transportation.

THIS WARRANTY IS EXCLUSIVE, AND IS IN LIEU OF ANY OTHER WARRANTIES, EXPRESS OR IMPLIED, INCLUDING BUT NOT LIMITED TO WARRANTY OF MERCHANTABILITY OR WARRANTY OF FITNESS FOR A PARTICULAR PURPOSE.

Graco's sole obligation and buyer's sole remedy for any breach of warranty shall be as set forth above. The buyer agrees that no other remedy (including, but not limited to, incidental or consequential damages for lost profits, lost sales, injury to person or property, or any other incidental or consequential loss) shall be available. Any action for breach of warranty must be brought within two (2) years of the date of sale.

Graco makes no warranty, and disclaims all implied warranties of merchantability and fitness for a particular purpose in connection with accessories, equipment, materials or components sold but not manufactured by Graco. These items sold, but not manufactured by Graco (such as electric motors, switches, hose, etc.), are subject to the warranty, if any, of their manufacturer. Graco will provide purchaser with reasonable assistance in making any claim for breach of these warranties.

In no event will Graco be liable for indirect, incidental, special or consequential damages resulting from Graco supplying equipment hereunder, or the furnishing, performance, or use of any products or other goods sold hereto, whether due to a breach of contract, breach of warranty, the negligence of Graco, or otherwise.

FOR GRACO CANADA CUSTOMERS

The parties acknowledge that they have required that the present document, as well as all documents, notices and legal proceedings entered into, given or instituted pursuant hereto or relating directly or indirectly hereto, be drawn up in English. Les parties reconnaissent avoir convenu que la rédaction du présente document sera en Anglais, ainsi que tous documents, avis et procédures judiciaires exécutés, donnés ou intentés à la suite de ou en rapport, directement ou indirectement, avec les procédures concernées.

Graco Information

For the latest information about Graco products, visit www.graco.com.

TO PLACE AN ORDER, contact your Graco distributor, or call one of the following numbers to identify the distributor closest to you:

1-800-328-0211 Toll Free

612-623-6921

612-378-3505 Fax

All written and visual data contained in this document reflects the latest product information available at the time of publication. Graco reserves the right to make changes at any time without notice.

This manual contains English. MM 306769

Graco Headquarters: Minneapolis

International Offices: Belgium, China, Japan, Korea

GRACO INC. P.O. BOX 1441 MINNEAPOLIS, MN 55440-1441

Copyright 1997, Graco Inc. is registered to ISO 9001

www.graco.com

Revised 07/2009