

XM Plural-Component Sprayers

313289J

EN

For spraying two-component epoxy and urethane protective coatings in hazardous and non-hazardous locations. For professional use only.



Important Safety Instructions

Read all warnings and instructions in this manual. Save these instructions.

See pages 7 and 8 for model information and agency approvals.

See page 85 for maximum working pressure.

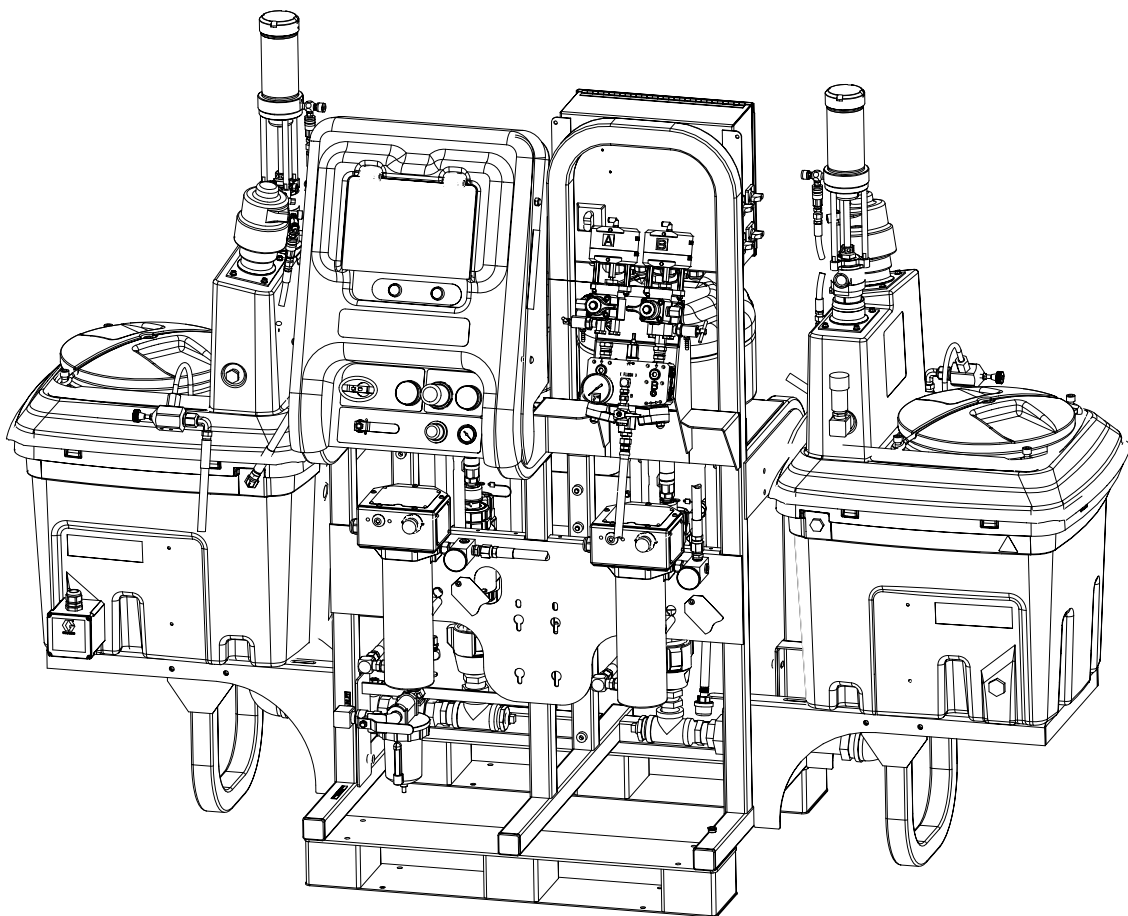

H003

Contents

Related Manuals	3	Electrical Schematics	47
Warnings	4	Simplified Electrical Schematic, XM Sprayer with Alternator	47
Models	7	Detailed Electrical Schematic, XM Sprayer with Alternator (page 1)	49
Overview	9	Simplified Electrical Schematic, XM Sprayer with Wall Power	51
Isocyanate Hazard	9	Detailed Electrical Schematic, XM Sprayer with Wall Power (page 1)	53
Material Self-Ignition	9	Junction Box Wiring Schematics	55
Moisture Sensitivity of Isocyanates	9	Fluid Heaters	55
Components A and B	10	Hopper Heaters	56
Changing Materials	10	Parts	58
Before Repair	11	Control Box (255771) Parts	70
Location	11	Control Box Power Supply Options	72
Grounding	11	Air Controls Module (255761) Parts	74
Proper Lifting of Sprayer	11	Junction Box (256540) Parts	75
Pressure Relief Procedure	12	Fluid Control Assembly Parts	76
Flush Before Using Equipment	13	Air Inlet Manifold (255762) Parts	77
Flush	14	Alternator Module (255728) Parts	78
Flush Mixed Material	14	Repair and Spare Parts Reference	79
Empty and Flush Entire System (new sprayer or end of job)	16	Accessories and Kits	80
Shutdown Entire System	18	Dimensions	82
Cleaning Procedure	18	System Dimensions without Hoppers	82
XM Setup and Troubleshooting Guide	19	System Dimensions with Hoppers	83
Troubleshooting	20	System Dimensions with Hoppers	84
Alarms	23	Technical Data	85
View Alarms	23	Graco Standard Warranty	86
Diagnose Alarms	23	Graco Information	86
Clear Alarms	23		
Alarm Codes and Troubleshooting	24		
LED Diagnostic Information	30		
Repair	31		
Replace Air Filter Element	31		
User Interface/Control Box	32		
Air Controls	40		
Fluid Control Assembly	42		
Sensors	43		
Pump Assembly	44		
Solvent Pump	46		
Fluid Heaters	46		

Related Manuals





Manuals are available at www.graco.com.

Component Manuals in U.S. English:





Manual	Description
312359	XM Plural-Component Sprayers Operation
313292	XM Plural-Component OEM Sprayers Instructions-Parts
311762	Xtreme® Displacement Pumps Instructions-Parts
311238	NXT™ Air Motor Instructions-Parts
312747	Double Wall Hopper Kit Instructions-Parts
309524	Viscon® HP Heater Instructions-Parts
312145	XTR™ 5 and XTR™ 7 Spray Guns Instructions-Parts
312769	Feed Pump and Agitator Kits Instructions-Parts
312794	Merkur® Pump Assembly Instructions-Parts
406699	7-Gallon Hopper Installation Kit Instructions-Parts
406739	Desiccant Kit Instructions-Parts
406690	Caster Kit Instructions-Parts
406691	Hose Rack Kit Instructions-Parts
313258	Electric Heated Hose Power Supply Kit Instructions-Parts
313259	Hopper or Hose Heat Circulation Kit Instructions-Parts
312770	Lower Strainer and Valve Kit Instructions-Parts
312749	XM Mix Manifold Kit Instructions-Parts
313293	Alternator Conversion Kits Instructions-Parts
313342	Dosing Valve Repair Kit Instructions-Parts
313343	High Flow Severe Duty Shutoff Check Valve Repair Kit Instructions-Parts

Warnings





The following warnings are for the setup, use, grounding, maintenance, and repair of this equipment. The exclamation point symbol alerts you to a general warning and the hazard symbol refers to procedure-specific risk. Refer back to these warnings. Additional, product-specific warnings may be found throughout the body of this manual where applicable.

 WARNING	
	<p>FIRE AND EXPLOSION HAZARD</p> <p>Flammable fumes, such as solvent and paint fumes, in work area can ignite or explode. To help prevent fire and explosion:</p> <ul style="list-style-type: none"> • Use equipment only in well ventilated area. • Eliminate all ignition sources; such as pilot lights, cigarettes, portable electric lamps, and plastic drop cloths (potential static arc). • Keep work area free of debris, including solvent, rags and gasoline. • Do not plug or unplug power cords, or turn power or light switches on or off when flammable fumes are present. • Ground all equipment in the work area. See Grounding instructions. • Use only grounded hoses. • Hold gun firmly to side of grounded pail when triggering into pail. • If there is static sparking or you feel a shock, stop operation immediately. Do not use equipment until you identify and correct the problem. • Keep a working fire extinguisher in the work area. • Do not connect USB device in explosive atmospheres.
	<p>SPECIAL CONDITIONS FOR SAFE USE</p> <ul style="list-style-type: none"> • To prevent the risk of electrostatic sparking, the equipment's non-metallic parts must be cleaned with only a damp cloth. • Refer to the Viscon HP Heater manual for special conditions for safe use.
	<p>ELECTRIC SHOCK HAZARD</p> <p>Improper grounding, setup, or usage of the system can cause electric shock.</p> <ul style="list-style-type: none"> • Turn off and disconnect power at main switch before disconnecting any cables and before servicing equipment. • Connect only to grounded power source. • All electrical wiring must be done by a qualified electrician and comply with all local codes and regulations.





! WARNING

	<p>INTRINSIC SAFETY</p> <p>Intrinsically safe equipment that is installed improperly or connected to non-intrinsically safe equipment will create a hazardous condition and can cause fire, explosion, or electric shock. Follow local regulations and the following safety requirements.</p> <ul style="list-style-type: none"> • Only models with model number XM_D__ or XM_E__, and packaged models with part numbers ending in 00-13, 17-23, 27-29, 31, utilizing the air-driven alternator are approved for installation in a Hazardous (explosive atmosphere) Location - see Approvals:, page 8. Only the models stated above meet all local safety fire codes including NFPA 33, NEC 500 and 516, and OSHA 1910.107. To help prevent fire and explosion: <ul style="list-style-type: none"> • Do not install equipment approved only for a non-hazardous location in a hazardous location. See model ID label for intrinsic safety rating of your model. • Do not substitute system components as this may impair intrinsic safety. • Equipment that comes in contact with the intrinsically safe terminals must be rated for Intrinsic Safety. This includes DC voltage meters, ohmmeters, cables, and connections. Remove the unit from the hazardous area when troubleshooting. • Do not connect, download, or remove USB device unless unit is removed from the hazardous (explosive atmosphere) location. • If explosion-proof heaters are used, ensure wiring, wiring connections, switches, and electrical distribution panel all meet flame-proof (explosion-proof) requirements.
	<p>SKIN INJECTION HAZARD</p> <p>High-pressure fluid from gun, hose leaks, or ruptured components will pierce skin. This may look like just a cut, but it is a serious injury that can result in amputation. Get immediate surgical treatment.</p> <ul style="list-style-type: none"> • Do not point gun at anyone or at any part of the body. • Do not put your hand over the spray tip. • Do not stop or deflect leaks with your hand, body, glove, or rag. • Do not spray without tip guard and trigger guard installed. • Engage trigger lock when not spraying. • Follow Pressure Relief Procedure in this manual, when you stop spraying and before cleaning, checking, or servicing equipment.
	<p>PRESSURIZED EQUIPMENT HAZARD</p> <p>Fluid from the gun/dispense valve, leaks, or ruptured components can splash in the eyes or on skin and cause serious injury.</p> <ul style="list-style-type: none"> • Follow Pressure Relief Procedure in this manual, when you stop spraying and before cleaning, checking, or servicing equipment. • Tighten all fluid connections before operating the equipment. • Check hoses, tubes, and couplings daily. Replace worn or damaged parts immediately.
	<p>MOVING PARTS HAZARD</p> <p>Moving parts can pinch or amputate fingers and other body parts.</p> <ul style="list-style-type: none"> • Keep clear of moving parts. • Do not operate equipment with protective guards or covers removed. • Pressurized equipment can start without warning. Before checking, moving, or servicing equipment, follow the Pressure Relief Procedure in this manual. Disconnect power or air supply.

! WARNING

	<p>EQUIPMENT MISUSE HAZARD</p> <p>Misuse can cause death or serious injury.</p> <ul style="list-style-type: none"> • Do not operate the unit when fatigued or under the influence of drugs or alcohol. • Do not exceed the maximum working pressure or temperature rating of the lowest rated system component. See Technical Data in all equipment manuals. • Use fluids and solvents that are compatible with equipment wetted parts. See Technical Data in all equipment manuals. Read fluid and solvent manufacturer's warnings. For complete information about your material, request MSDS forms from distributor or retailer. • Check equipment daily. Repair or replace worn or damaged parts immediately with genuine manufacturer's replacement parts only. • Do not alter or modify equipment. • Use equipment only for its intended purpose. Call your distributor for information. • Route hoses and cables away from traffic areas, sharp edges, moving parts, and hot surfaces. • Do not kink or over bend hoses or use hoses to pull equipment. • Keep children and animals away from work area. • Comply with all applicable safety regulations.
	<p>TOXIC FLUID OR FUMES HAZARD</p> <p>Toxic fluids or fumes can cause serious injury or death if splashed in the eyes or on skin, inhaled, or swallowed.</p> <ul style="list-style-type: none"> • Read MSDS's to know the specific hazards of the fluids you are using. • Store hazardous fluid in approved containers, and dispose of it according to applicable guidelines. • Always wear impervious gloves when spraying or cleaning equipment.
	<p>BURN HAZARD</p> <p>Equipment surfaces and fluid that's heated can become very hot during operation. To avoid severe burns, do not touch hot fluid or equipment. Wait until equipment/fluid has cooled completely.</p>
	<p>PERSONAL PROTECTIVE EQUIPMENT</p> <p>You must wear appropriate protective equipment when operating, servicing, or when in the operating area of the equipment to help protect you from serious injury, including eye injury, inhalation of toxic fumes, burns, and hearing loss. This equipment includes but is not limited to:</p> <ul style="list-style-type: none"> • Protective eyewear • Clothing and respirator as recommended by the fluid and solvent manufacturer • Gloves • Hearing protection

Models

						
<p>XM sprayers are not approved for use in hazardous locations unless the base model, all accessories, all kits, and all wiring meet local, state, and national codes.</p>						

Check the identification plate (ID) for the 6-digit part number of the sprayer. Use the following matrix to define the construction of the sprayer, based on the six digits. For example, Part **XM1A00** represents an XM Plural-Component sprayer (**XM**); 5200 psi pump set with pump filters (**1**); wall power supply, no heaters, no junction box, and is not approved for hazardous areas (**A**); with no additional kits (**00**).

NOTE:

Some configurations in the following matrix cannot be built. See the Product Selection Guide for available systems. If option(s) for third, fourth, fifth, and sixth digits is blank, the option(s) is not included with that particular configuration.

To order replacement parts, see **Parts** section in this manual. The digits in the matrix do not correspond to the Ref. Nos. in the Parts drawings and lists.

XM	1			A						00	
First and Second Digits	Third Digit			Fourth Digit						Fifth and Sixth Digits	
	System Choice (See Table 1 for lower models)			Kit Choice						Additional Kit	
		Pump Set (hose/gun)	Pump Filters	Remote Manifold		Control Box	Fluid Heaters	Junction Box	Location Category	Approvals (See page 8 for approvals)	See Table 2 for selections
XM (plural component sprayer mounted on a frame)	1	5200 psi	✓		A	Wall Power Supply			NE	CE, FM, FMc	
	2	5200 psi			B	Wall Power Supply	✓	✓	NE	CE, FM, FMc	
	3	6300 psi	✓		D	IS/ Alternator			EH	CE, FM, FMc, Ex	
	4	6300 psi			E	IS/ Alternator	✓		EH	CE, FM, FMc, Ex	
	5	5200 psi	✓	✓							
	6	5200 psi		✓							
	7	6300 psi	✓	✓							
	8	6300 psi		✓							

Location Category Key:

NE Not for use in European explosive atmosphere locations or hazardous locations.

EH For use in explosive atmospheres and hazardous locations.

Approvals:

See appropriate column on page 7.



XM _ A _ _ XM _ B _ _	XM _ D _ _ XM _ E _ _
 FM <small>C US</small> APPROVED	 FM <small>C US</small> APPROVED Intrinsically safe for Class I, Div 1, Group D, T2 Class I, Division 1, Group D, T2 Ta = 0°C to 54°C
 FM09ATEX0015X II 2 G Ex d ia px IIA T2 Tamb = 0°C to 54°C	
See Special Conditions for Safe Use in Warnings , page 4.	

Table 1: Lower Models and Corresponding Identification Codes

Code	System Pressure (MPa, bar)	Pump Filters	A Lower (see manual 311762)	B Lower (see manual 311762)
1 or 5	5200 psi (35, 350)	✓	L250C4	L220C4
2 or 6	5200 psi (35, 350)		L250C3	L220C3
3 or 7	6300 psi (49, 490)	✓	L180C4	L145C4
4 or 8	6300 psi (49, 490)		L180C3	L145C3

Table 2: Additional Kits - Identification Code Index





	20 Gal. Hopper Kit	Hopper Heater Kit 240V	Hopper Fluid Inlet Kit	Hopper Universal Mount Kit	Twistork Agitator Kit	T2 Pump Feed Kit (on hopper)	5:1 Pump Feed Kit (on hopper)	7 Gal. Hopper and Bracket Kit	Drum Feed Kit (Dual T2 and Agitator)	Drum Feed Kit (Dual 5:1 and Agitator)	Heated Hopper/ Hose Circulation Kit
00											
11	1		1	1	1			1			
13	1			1	1		1	1			
14	1	1	1	1	1			1			
15	1	1		1	1	1		1			
16	1	1		1	1		1	1			
17	1		1	1	1			1			1
19	1			1	1		1	1			1
21	2		2	2	2						
23	2			2	2		2				
24	2	2	2	2	2						
25	2	2		2	2	2					
26	2	2		2	2		2				
27	2		2	2	2						1
29	2			2	2		2				1
30									2		
31										2	

NOTE:





See **Repair and Spare Parts Reference**, page 79, for more information.

See **Related Manuals**, page 3, for kit manual numbers.



Overview

						
<p>XM sprayers are not approved for use in hazardous locations unless the base model, all accessories, all kits, and all wiring meet local, state, and national codes. See Models, page 7, to determine the appropriate location for your particular model.</p>						

Isocyanate Hazard

						
<p>Spraying materials containing isocyanates creates potentially harmful mists, vapors, and atomized particulates.</p> <p>Read material manufacturer's warnings and material MSDS to know specific hazards and precautions related to isocyanates.</p> <p>Prevent inhalation of isocyanate mists, vapors, and atomized particulates by providing sufficient ventilation in the work area. If sufficient ventilation is not available, a supplied-air respirator is required for everyone in the work area.</p> <p>To prevent contact with isocyanates, appropriate personal protective equipment, including chemically impermeable gloves, boots, aprons, and goggles, is also required for everyone in the work area.</p>						

Material Self-Ignition

						
<p>Some materials may become self-igniting if applied too thick. Read material manufacturer's warnings and material MSDS.</p>						

Moisture Sensitivity of Isocyanates

Isocyanates (ISO) are catalysts used in two component foam and polyurea coatings. ISO will react with moisture (such as humidity) to form small, hard, abrasive crystals, which become suspended in the fluid. Eventually a film will form on the surface and the ISO will begin to gel, increasing in viscosity. If used, this partially cured ISO will reduce performance and the life of all wetted parts.

NOTE:

The amount of film formation and rate of crystallization varies depending on the blend of ISO, the humidity, and the temperature.

To prevent exposing ISO to moisture:

- Always use a sealed container with a desiccant dryer in the vent, or a nitrogen atmosphere. **Never** store ISO in an open container.
- Keep the ISO lube pump reservoir filled with Graco Throat Seal Liquid (TSL), Part 206995. The lubricant creates a barrier between the ISO and the atmosphere.
- Use moisture-proof hoses specifically designed for ISO, such as those supplied with your system.
- Never use reclaimed solvents, which may contain moisture. Always keep solvent containers closed when not in use.
- Never use solvent on one side if it has been contaminated from the other side.
- Always park pumps when you shutdown.
- Always lubricate threaded parts with Part 217374 ISO pump oil or grease when reassembling.

Components A and B

IMPORTANT!

Material suppliers can vary in how they refer to plural component materials.

Be aware that in this manual:

Component A refers to resin or major volume.

Component B refers to the hardener or minor volume.

NOTE:

This equipment doses the B component into the A component flow. An integration hose must always be used after the mix manifold.

Follow these recommendations for reassembly and setup:

- use at least a 3/8 in. (10 mm) x 25 ft. (7 m) hose.
- install a 24-element static mix tube after the integration hose.

Keep Components A and B Separate

NOTICE

To prevent cross-contamination of the equipment's wetted parts, **never** interchange component A (resin) and component B (hardener) parts.

Changing Materials

- When changing materials, flush the equipment multiple times to ensure it is thoroughly clean.
- Always clean the fluid inlet strainers and outlet filter after flushing. See **Flush** on page 14.
- Check with your material manufacturer for chemical compatibility.
- Epoxies often have amines on the B (hardener) side. Polyureas often have amines on the A (resin) side.

NOTE:

If the amine will switch between the two sides, see **Flush** on page 14.

Before Repair

Location

--	--	--	--	--	--	--

XM sprayers are not approved for use in hazardous locations unless the base model, all accessories, all kits, and all wiring meet local, state, and national codes. See **Models**, page 7, to determine the appropriate location for your particular model.

Grounding

--	--	--	--	--	--	--

Connect ground wire clamp (FG) to a true earth ground. If wall power is used to power controls or heaters, ground electrical connection properly according to local codes.

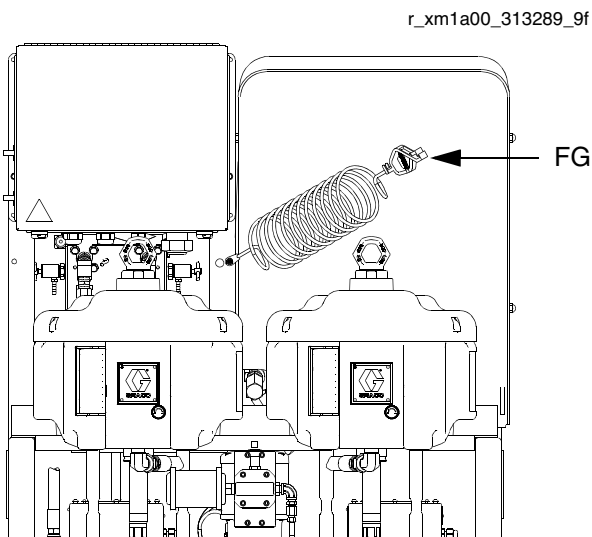

Proper Lifting of Sprayer

--	--	--	--	--	--	--

Follow instructions to avoid serious injury or damage to equipment. Never lift with the hopper(s) filled.

Lift Using a Forklift

Power must be off. Sprayer can be raised and moved using a forklift. Carefully lift the sprayer; make sure it balances evenly.

Lift Using a Hoist

Sprayer can also be lifted and moved using a hoist. Connect a bridle swing, hooking an end to each of the air motor lift rings. Hook the center ring to a hoist. Carefully lift the sprayer; make sure it balances evenly.

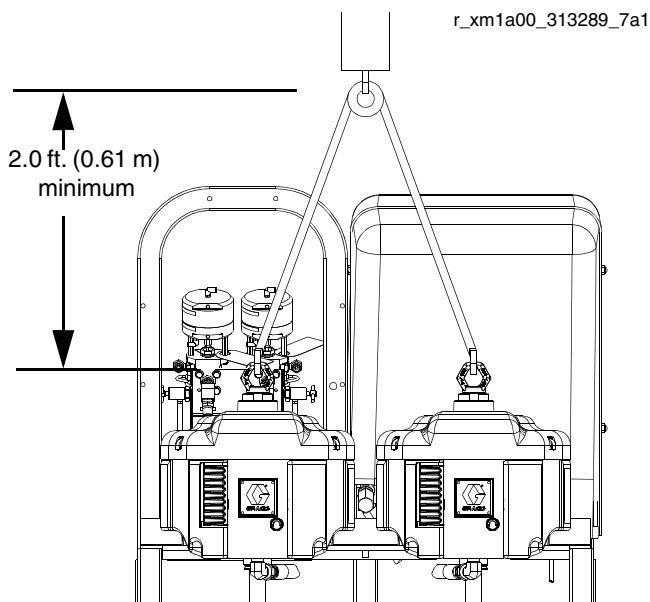

Pressure Relief Procedure

<p>Follow Pressure Relief Procedure when you stop spraying or dispensing; and before cleaning, checking, servicing, or transporting equipment.</p>						

Relieve A and B Fluid Pressure

1. Engage trigger lock.

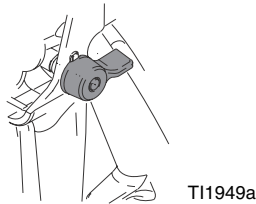

2. Press .

3. If fluid heaters are used, shut them off using the controls on the heater control box.

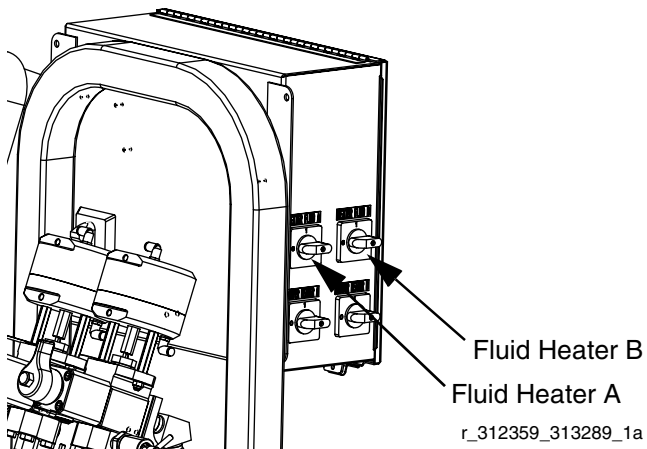

4. Shut off feed pumps, if used.
5. Remove spray tip and clean.
6. Disengage trigger lock.

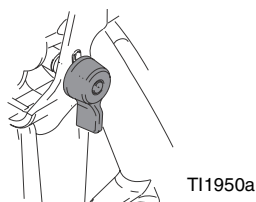

7. Hold a metal part of the gun firmly to a grounded metal pail with a splash guard in place. Trigger gun to relieve pressure in material hoses.

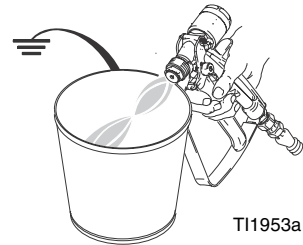

8. Engage trigger lock.

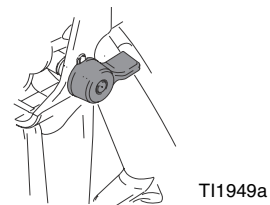

Relieve Pump Fluid Pressure

9. Close mix manifold valves (AH, AJ), then open solvent flush valve (AK) on mix manifold.

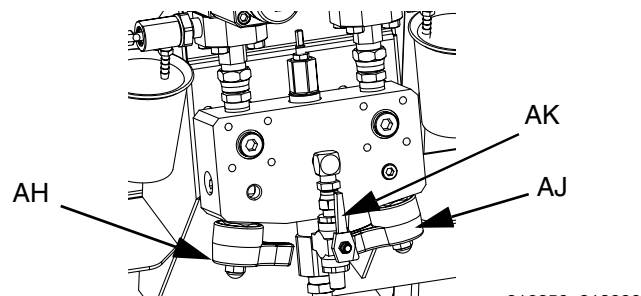

10. Open solvent pump air control (CB). Use lowest pressure needed to flush material out of hose.

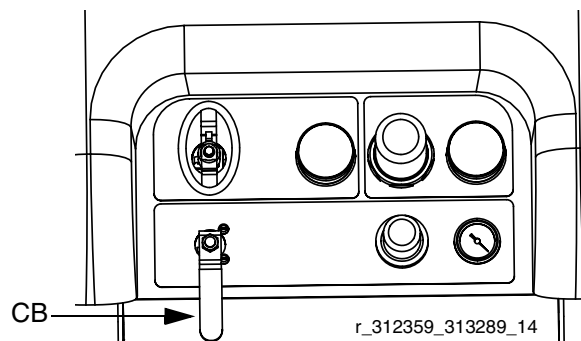

11. Disengage trigger lock.

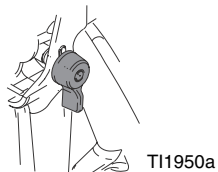

12. Hold a metal part of the gun firmly to a grounded metal pail with a splash guard in place. Trigger gun to flush mixed material out of line with clean solvent.
13. Shut off solvent pump on air control panel.
14. Repeat steps 11 and 12. Then continue to step 15.
15. Close solvent flush valve (AK) on mix manifold.

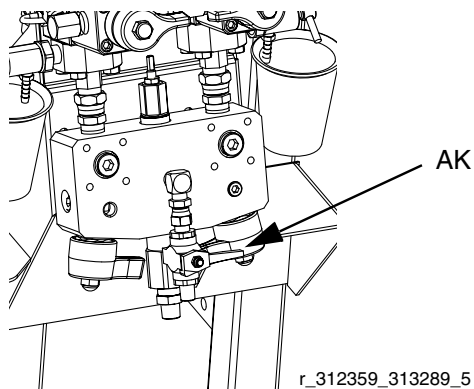

16. Release any residual gun pressure and engage trigger lock.

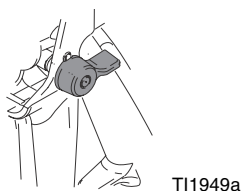

Flush Before Using Equipment

The equipment was tested with lightweight oil, which is left in the fluid passages to protect parts. To avoid contaminating your fluid with oil, flush the equipment with a compatible solvent before use. See **Flush** on page 14.

Flush

Flush Mixed Material



Flush Mix Manifold

Use Solvent Pump

1. Press  to turn off system. Follow **Pressure Relief Procedure**, page 12. Engage trigger lock. Remove spray tip.



TI1949a

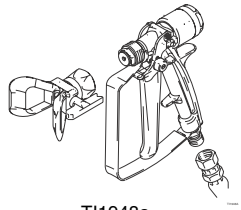

TI1948a

2. Close sampling valves (AE, AF) and mix manifold valves (AH, AJ).

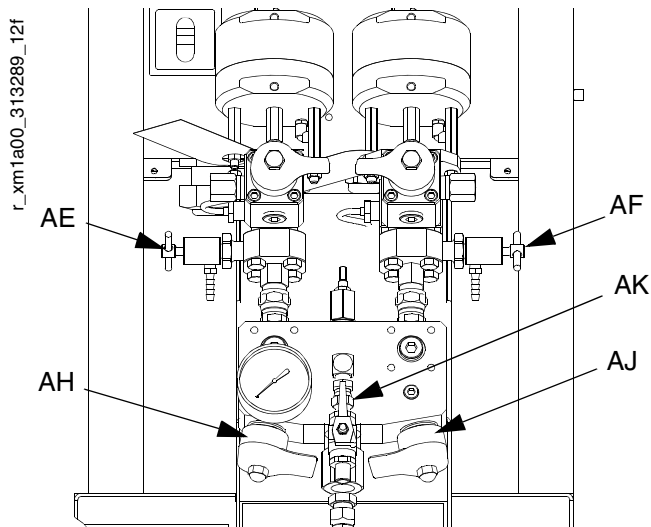

3. Open solvent shutoff valve (AK) at mix manifold.

4. Open solvent pump air control (CB). Pull out and slowly turn solvent pump air regulator (CG) clockwise to increase air pressure. Use lowest possible pressure.

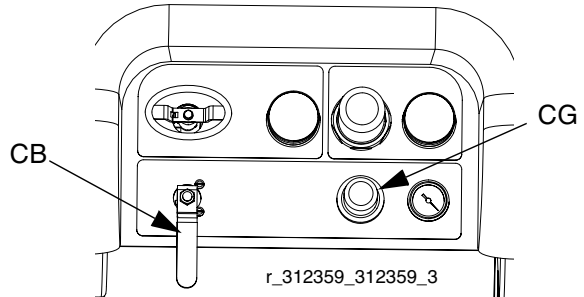

5. Disengage trigger lock. Hold a metal part of the gun firmly to a grounded metal pail with a splash guard in place. Use a pail lid with a hole in it to dispense through. Be careful to keep fingers away from the front of the gun. Trigger gun until solvent appears.

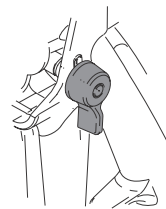

TI1950a

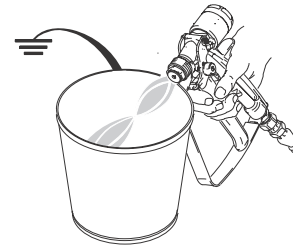

TI1953a

6. Engage trigger lock.

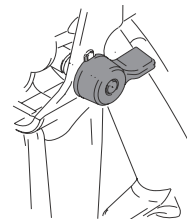

TI1949a

7. Close solvent pump air valve (CB) and solvent shut-off valve (AK) at mix manifold.

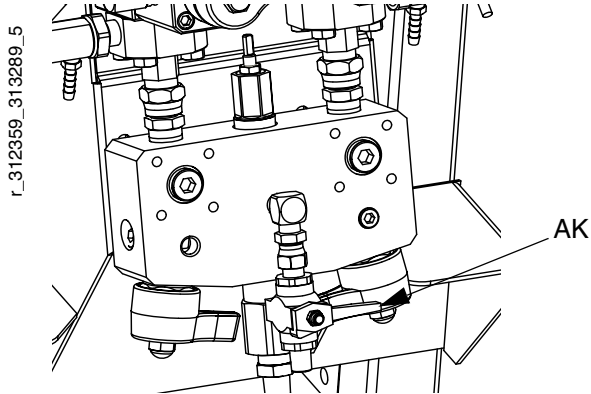

8. Follow **Pressure Relief Procedure**, page 12.
9. Engage trigger lock.

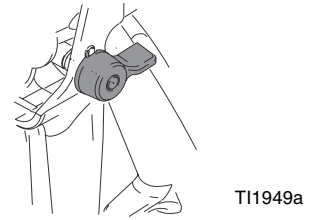

10. Disassemble and clean spray tip with solvent by hand. Reinstall on the gun.

Empty and Flush Entire System (new sprayer or end of job)



NOTE:

- If system includes heaters and heated hose, turn them off and allow to cool before flushing. **Do not turn on heaters until fluid lines are clear of solvent.**
- Use the lowest possible pressure when flushing to avoid splashing.
- Before color change or shutdown for storage, flush at a higher flow rate and for a longer time.
- To flush only mix manifold, see **Flush Mix Manifold** procedure page 14.

Guidelines

Flush new systems if coating materials will be contaminated by 10W oil.

Flush system when any of the following situations occur. Flushing will help prevent materials from clogging the line between hoppers and pump inlets.

- anytime sprayer will not be used for more than one week
- if materials used will settle
- if using thixotropic resins that require agitation

Procedure

1. Follow **Pressure Relief Procedure**, page 12, and **Flush Mixed Material**, page 14, as required. Engage trigger lock. Turn main pump air regulator (CD) fully counter-clockwise to shut off.

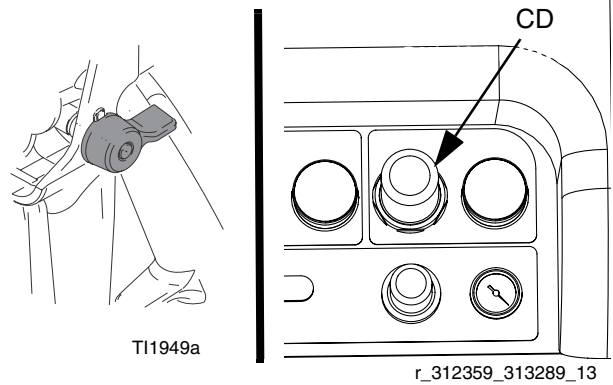

NOTE:

When flushing coating materials remove pump fluid filters, if installed, and soak in solvent to decrease cleaning time. Proceed with Step 2. If flushing a new system, leave filters in place.

2. Move circulation return lines to separate fluid containers to pump remaining fluid out of system.
3. Increase main pump air regulator (CD) pressure to 30 psi (21 kPa, 2.1 bar).

4. Select . Press .

NOTE:

When running pumps independently set to or . Press and as needed to clean.

NOTE:

If sprayer does not start with static pressure, increase air pressure by 10 psi (69 kPa, 0.7 bar) increments. To avoid splashing do not exceed 40 psi (28 kPa, 2.8 bar).

- Open recirculation valves (AC, AD) for respective pump dispense side. Run pumps until the A and B reservoirs are empty. Salvage the material in separate, clean containers.

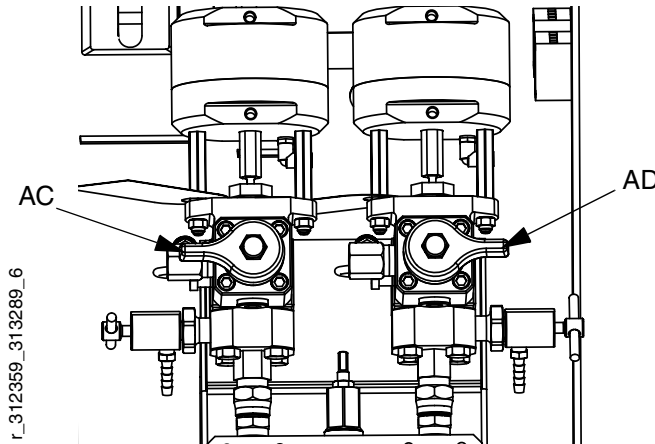

NOTE:

When priming or flushing the pumps, it is normal to get cavitation or pump runaway alarms. Clear the alarms

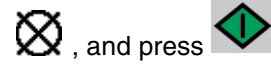

, and press  again as necessary. These alarms prevent excessive pump speeds that can damage pump packings.

- Wipe the reservoirs clean, then add solvent to each. Move circulation lines to waste containers.
- Repeat Step 4 to flush through each side until clean solvent exits recirculation hose.
- Stop and move recirculation hoses back to reservoirs. Continue recirculating until machine is thoroughly flushed.

- Close recirculation valves (AC, AD) and open mix manifold valves (AH, AJ). Dispense fresh solvent through mix manifold valves and out gun.

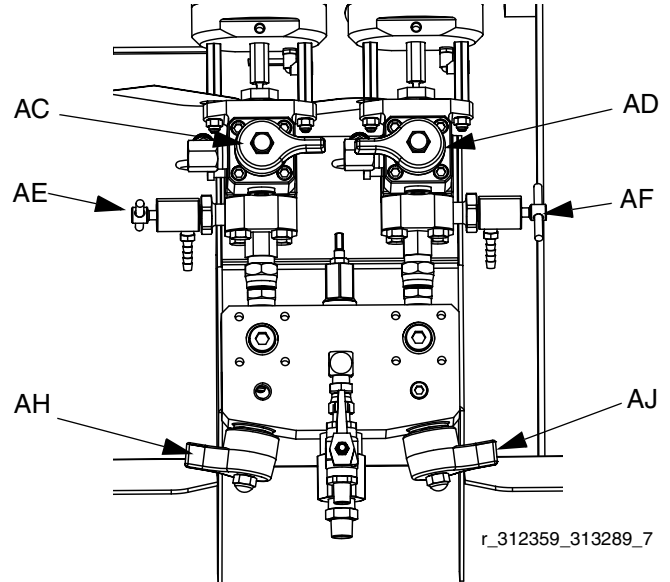

- Close mix manifold valves (AH, AJ).
- Slowly open sampling valves (AE, AF) to flush solvent through until clean. Close sampling valves.

Press .

- Follow **Pressure Relief Procedure**, page 12.
- Remove pump fluid filters, if installed, and soak in solvent. Clean and replace filter cap. Clean filter o-rings and leave out to dry. Do not leave o-rings in solvent.
- Close main air valve (E).

NOTE:

Always leave some type of fluid, such as solvent or oil, in the system to prevent scale build up. This build up can flake off later. Do not use water.

Shutdown Entire System

Follow this procedure before prolonged shutdown or before servicing equipment.

1. Follow **Pressure Relief Procedure**, page 12. Place gun over pail. Trigger gun; wait until pumps are down.

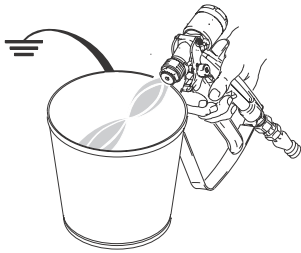

TI1953a

2. Engage trigger lock, turn off air regulator, and close main air shutoff valve. Remove spray tip.



TI1949a

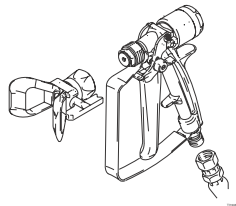

TI1948a

3. Follow flushing procedure, see **Flush** on page 14.
4. Follow **Pressure Relief Procedure**, page 12. Engage trigger lock.

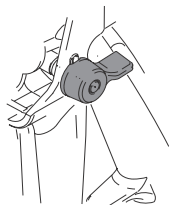

TI1949a

5. *For prolonged shutdown (one week or longer):*
 - Follow flushing procedure, see **Empty and Flush Entire System (new sprayer or end of job)** on page 16.
 - Cap fluid outlets to keep solvent in the lines.
 - Fill pump A and B packing nuts with throat seal liquid (TSL).

Cleaning Procedure

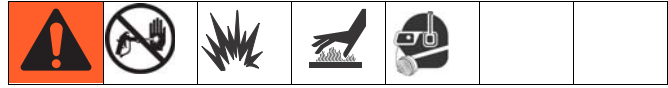

1. Ensure all equipment is grounded. See **Grounding**, page 11.
2. Turn off all heaters and allow equipment to cool.
3. Flush mixed material. See **Flush Mixed Material**, page 14.
4. Relieve pressure. See **Pressure Relief Procedure**, page 12.
5. Shutdown sprayer and turn off all power. See **Shutdown Entire System**, page 18.
6. Ensure the area where the sprayer will be cleaned is well ventilated; and remove all ignition sources.
7. Clean external surfaces using only a rag soaked in solvent that is compatible with the spray material and the surfaces being cleaned.
8. Allow enough time for solvent to dry before using sprayer.

XM Setup and Troubleshooting Guide

The following setup information will help ensure the system is setup properly. See the XM repair-parts manual for troubleshooting and repair instructions.

Grounding

- Ground system to a true earth ground.
- Ensure incoming power is grounded.

Air Supply

- Use at least a 3/4 in. (19mm) ID air hose, no longer than 50 feet (15m).
- Ensure the first gauge (supply) stays above 80 psi (0.55 MPa, 5.5bar) while spraying.
- Ensure that the pump spray pressure regulator is set to at least 35 psi (2.4 bar) for spraying.
- Ensure that the solenoid air filter/regulator behind the air panel is set to at least 80-85 psi.
- Check that the air filter element in the solenoid air filter/regulator behind the air panel is clean.

Calibration

- Adjust the B side fluid restrictor so that the calibration bar graph averages center to right middle. This means that the “B” dosing valve is open 25% to 75% of the time.
- Ensure dosing valve needle packing nuts are not adjusted too tight? They should be snug when there is no fluid pressure on the valve.
- If feed pumps are used, don't use more than 250psi (17 bar). Excess pressure adds double the amount of pressure on only the upstroke of the XM metering pump.

Motor Icing

Air motors accumulate ice in the exhaust valving and muffler under hot and humid conditions or under cold ambient conditions. It can cause pressure loss or motor stalling.

- The ‘B’ fluid pressure should always be 15% to 30% higher than ‘A’ pressure.
- A larger pressure difference indicates ‘A’ motor icing.
- A smaller or negative pressure difference indicates ‘B’ motor icing.

- Ensure that the NXT motor De-Ice bleed valves are open to bleed warm air across the ice.
- Ensure that the motor is left active when not spraying to keep the internal bleed air working. Leave the motor active in Spray mode or Manual mode to keep the bleed air on.

Restrictions or Lost Pressure

- Always use filter screens in the XM pump lowers. Filter style pumps come with 60 mesh screens. Optional 30 mesh elements are also supplied.
- Always use a gun filter. 60 mesh is provided in the gun. Check that the static mixer is clean.
- Early mix manifolds (2009) had a 40 mesh screen on the B side. The screen could plug with materials that have filled ‘B’ side fluids.

Remote Mix Manifold Applications

Ensure remote mix manifold outlet kit is installed. See XM Repair parts manual. The kit includes outlet check valves which isolate the pump pressure sensors from the outlet hoses, and includes a ‘B’ side restrictor valve for the machine outlet.

NOTE: Early remote manifold machines didn't include the ‘B’ restrictor valve from the factory.

- Ensure that the ‘A’ and ‘B’ outlet hose sizes volume balanced close to the mix ratio. Unbalanced hose sizes can cause off ratio slugs at the mix manifold during pressure and/or flow transitions. See XM Mix Manifold Kits manual.
- If a minimum of integration and mix hose is used, ensure that “Fast Dosing” is selected in the setup screens?

Software Version

- Ensure all modules in the system use software from same token. Different software versions may not be compatible.
- The latest software version for each system can be found at Tech Support at www.graco.com.

Troubleshooting



NOTE:

If an error code displays, see **Alarms** on page 23.

NOTE:

The sprayer operates using air pressure. Many problems are caused by inadequate air supply. The inlet air pressure gauge cannot drop below 50 psi (0.35 MPa, 3.5 bar) while running.

Problem	Cause	Solution
Display not lit on system with alternator power supply. No electric power.	Air valve not turned on.	Turn on main air valve to system.
	Air supply pressure too low.	Increase pressure to 30 psi (0.21 MPa, 2.1 bar) or greater.
	Air supply filters plugged. Inlet manifold filter (604) or air regulator (344) filter plugged.	Clean filter bowls; replace filter elements. Page 31.
	Turbine air regulator (277) set too low.	Adjust to 18 +/- 1 psi (12.6 +/- 10 kPa, 1.26 +/- 0.07 bar).
	Alternator turbine failure.	Repair or replace turbine. Page 38.
	Power supply not connected to main board.	Check power connections to main board. See Electrical Schematics , starting on page 47.
	Display board failure.	Replace display board. Page 36.
Display not lit on system with alternator power. Green light is present on FCM (218) and USB (219), but no green light is present on back of display module (204).	Faulty CAN cable (268). Or CAN cable is disconnected.	Check cable and replace. See Alternator Assembly , page 72.
	Faulty display module.	Replace display module. See User Interface/Control Box , page 32.
Display not lit on system with wall power supply. No green light present on back of display module (204).	No electric power. Disconnect “off” or breaker “open.”	Reset main disconnect and breaker.
	No green lights present on display, FCM, or USB module.	Check for 24 Vdc on J1, pins 2 and 3, of power supply. See Electrical Schematics , starting on page 47. If there is not 24 Vdc, replace with 15V747.
	No display power through CAN cable (266). Green light is present on FCM (218), but is not present on USB module (219).	Check CAN cable. Replace if necessary. See Wall Power Supply Assembly , page 73.
	Green light is present on USB module (219).	Check CAN cable (274). Replace if necessary. See Wall Power Supply Assembly , page 73.
Display not lit on system with wall power supply. Green light is present on back of display module (204).	Display module failed.	Replace display module. See User Interface/Control Box , page 32.

Problem	Cause	Solution
Pumps do not run when Run Mode is selected and the blue LED is illuminated.	Air pressure to pumps too low	Increase pressure to 50 psi (0.35 MPa, 3.5 bar) or greater.
	Air pilot lines are obstructed	Check pilot lines for kinks or pinches.
	Solenoid valve stuck.	Actuate solenoid manually, if it does not operate, replace solenoid. Page 32.
	Air pilot valve(s) to motor stuck.	Replace valve(s). Page 42.
	Metering valve(s) not opening.	Service or replace valve(s). Page 42.
	Air motor stalled.	See manual 311238.
Pump Test completes without error, but A or B component has more than 750cc of fluid in beaker.	Incorrect pumps were selected in System Setup screens.	See Appendix A in manual 312359.
	Air is trapped in fluid due to excessive agitation, circulation, and heat. Fluid is measured by volume when it is compressed under pressure.	Repeat Pump Test with fresh fluid. If the specific gravity of each fluid is known, check samples by weight (750cc x specific gravity equals weight in grams). If weight is correct, extra volume in beaker is air.
Batch Test completes without error, but A or B component has more fluid in beaker than displayed on screen.	See causes for previous pump test problem.	See solutions for previous pump test problem.
Sprayer does not start when start button is pressed.	Faulty start switch or wire harness.	Check start switch and wiring harness continuity; switch is normally open circuit. See Electrical Schematics , starting on page 47.
	Faulty stop switch or wiring harness.	Check stop switch and wiring harness continuity; stop switch is normally closed circuit. See Electrical Schematics , starting on page 47.
Fluid valves leaking.	Loose or worn packings.	Tighten packing nut. If leak continues, replace packings.
Paint does not cure consistently.	Ratio not set correctly.	Check that correct ratio is set and set by volume. See manual 312359.
	Material not mixing correctly.	Test pump. Make sure mixer is clean; flush as needed. See manual 312359. Position mixer after integrator hose.
	Material not properly conditioned before it was added to sprayer.	Mix material thoroughly.
	Not using enough integration hose.	Add more integration hose. Select "fast dosing" in setup.
Poor spray pattern. Also, see "System runs erratically" below.	Fluid pressure too low.	Increase pump pressure.
	Fluid temperature too low.	Increase fluid temperature.
	Spray tip dirty or worn.	Relieve pressure. Clean or replace tip. Follow gun manual instructions.
	Fluid A or B filters plugged. Mixer or hoses partially plugged or too restrictive.	Clean filters. See pump manual. Inspect parts for cured material. Clean or replace, or use larger hoses and mixer.

Problem	Cause	Solution
System runs erratically.	Air filter(s) clogged. Replace elements.	Clean. Replace element(s). See page 31.
	Air supply hoses undersized.	Replace hoses with appropriate size.
	Air compressor undersized.	Use larger air compressor.
	Air supply pressure tank undersized.	Use larger pressure tank.
	Inlet air pressure gauge drops below 50 psi (0.35 MPa, 3.5 bar) while spraying.	See solutions above for system runs erratically problem.
	A and/or B air motor has ice.	Open air motor de-ice bleed air control. Allow ice to melt. Dry the compressed air. Heat the compressed air. Use a smaller tip and lower flow rate.
	Pump is binding.	Repair lower. See Remove Displacement Pump , page 44.
Air supply relief valve opens.	Air regulator set too high.	Lower setting.
Turbine alternator makes high-pitched whining noise, or quits.	Turbine bearings worn. (Setting turbine air regulator too high, wears bearings.)	Replace turbine cartridge. See Alternator Power Supply Control Components , page 38.
Display module cycles on and off.	Turbine is not supplying enough power to board.	Increase turbine regulator setting to 18 +/- 1 psi (12.6 +/- 10 kPa, 1.26 +/- 0.07 bar). Check voltages on information screen. 10-14 Vdc when spraying.
		Check turbine and electrical control exhaust air for restrictions.
		Replace turbine cartridge. See Alternator Power Supply Control Components , page 38.
Flow rate too low.	Air supply hose is too small or too long.	Use 3/4 in. (minimum) ID hose. See Technical Data , page 85.
	Inadequate air supply.	Use larger CFM compressor.
	Air pressure to pumps too low.	Increase pressure.
	Fluid A or B filters plugged.	Clean filters. See pump manual.
	Spray tip too small.	Relieve pressure. Install larger tip. Follow gun manual instructions.
	Mixer or hoses partially plugged or too restrictive.	Inspect parts for cured material. Clean or replace, or use larger hoses and mixer.
Receive ratio alarm after starting in spray mode while using remote mix manifold.	A and B hoses do not fill to correct pressure ratio simultaneously. Therefore, spray time increases in order to balance pressure. Ratio screen bar graph stays to one side until pressure balances.	While in circulation mode, close circulation valves and increase pressure in hoses until correct spray pressure is achieved. Select correct hose size to balance your volume ratio. See manual 312749.
Receive ratio alarm while using remote mix manifold after a significant change in pressure.	A and B hoses do not fill to correct pressure ratio simultaneously. Therefore, spray time increases in order to balance pressure. Ratio screen bar graph stays to one side until pressure balances.	While in circulation mode, close circulation valves and increase pressure in hoses until correct spray pressure is achieved.
		Select correct hose size to balance your volume ratio. See manual 312749.
		Change pressure slowly while spraying.
Erratic pressure at spray gun when using feed pumps.	Feed pressure is too high. Feed pressure at metering pump is too high on up stroke. Doubles the feed pressure to outlet pressure on up stroke only.	Use lowest feed pressure needed to maintain feed.

Alarms

View Alarms

When an alarm occurs the alarm information screen automatically displays. It shows the current alarm code along with a bell icon. It also shows the alarm location with top and side views of the sprayer.

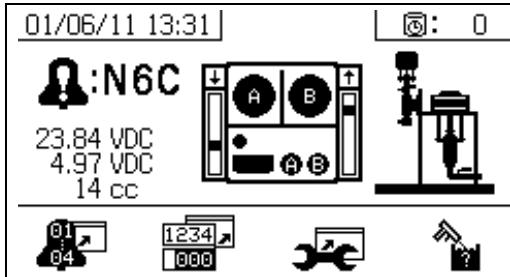

There are two levels of alarms: warnings and advisories. A bell icon indicates an alarm. A solid bell icon with an exclamation point and three audible alerts indicate a warning. And an outlined hollow bell icon and a single audible alert indicate an advisory.

Advisories are notifications that require attention but not immediately. Alarms require immediate correction; therefore, sprayer operation automatically stops.

This screen also shows diagnostic information. There are three lines of data on the left side. The top line shows the power supply or alternator power supply. This should be between 23-25 Volts for power supply systems and 10-14 Volts for alternator systems. The middle line shows the sensor voltage. This should be between 4.9-5.1 Volts.

The center of the screen shows linear sensor vertical bar graphs and reed switch information. The A side information is on the left and the B side information is on the right. Linear sensor position is displayed on the bar graph that goes up and down when the pump moves. This bar graph should move from top to bottom to match each pump stroke.

The state of the two reed switches in each air motor are shown with the arrow above each vertical bar graph.

Icon	Function
	Moving up
	Moving down
	Top changeover
	Bottom changeover
	One reed switch signal is missing
	Blank: No reed switch signal

Diagnose Alarms

See **Alarm Codes and Troubleshooting** for causes and solutions to each alarm code.

Clear Alarms

Press to clear alarms and advisories. From the alarm information screen, press to return to the run (fluid control) screen.

Alarm Codes and Troubleshooting

Alarm Code	Alarm Problem	When Active	Cause	Solution			
General Performance Alarms							
R4B	Ratio High B (Overdose B), system delivering too much B component.	Spray	B Dosing valve not closing.	Perform Pump Test to test for leakage. See Pump and Metering test in manual 312359. Loosen valve packing nut. Check air signal at valve top Repair valve or air solenoid. See Replace Solenoid Module , page 32.			
			No B restriction at mix manifold.	Increase B Restriction by turning B restrictor stem clockwise. See Adjust B Mix Manifold Restriction in manual 312359.			
			Pump filter plugged on A side.	Clean filter. See manual 311762. Use alternate 30 mesh screen. See manual 311762 for part number.			
			Inlet air dropping below 80 psi (0.55 MPa, 5.5 bar) while spraying. B dosing valve not closing correctly.	Check air filters. See Air Controls , page 40. Use larger air hose. Use larger compressor. Use smaller gun tips or less guns to reduce flow rate.			
			Solenoid air regulator set below 80 psi (0.55 MPa, 5.5 bar)	Adjust air regulator.			
			R1B	Ratio Low B (under dose B); system delivering not enough B component.	Spray	B dosing valve will not open.	Check for air signal to valve.
						B mix manifold valve closed.	Open green mix manifold valve.
			Pump filter plugged on B side.	Use alternate 30 mesh screen. See manual 311762 for part number. Clean B pump outlet filter. See manual 311762.			
REC	System detected five R4B (ratio high B) or five R1B (ratio low B) alarms within five minutes. Sprayer shuts down for five minutes to resolve problem.	Spray	See R4B or R1B alarm causes.	See R4B or R1B alarm solutions. Flush mixed material if necessary, and purge off-ratio mixed material in hose.			
FHA FHB	System detects pump movement (fluid flow) when valves are closed.	Spray	Recirculation valve or dosing valve open or leaking for more than 5 seconds.	Close or repair recirculation valve, and run Pump Test. See Pump and Metering test in manual 312359. See Mix Manifold Assembly , page 42.			
R2D	Dosing sizes are not optimized.	Spray	Dosing valve is operating near high or low timing limits.	Adjust mix manifold B restrictor stem clockwise or counter clockwise as indicated by bar graph on restrictor screen. See Adjust B Mix Manifold Restriction in manual 312359.			

Alarm Code	Alarm Problem	When Active	Cause	Solution
P4A P4B	Pressure high	Always	Fluid pressure is above maximum.	Decrease main air regulator or feed pump pressure.
DAA DAB	Pump runaway, above 80 cpm for 10 sec.	Always	No material in pump or lines; no fluid restriction.	Refill material in tank or hoses; install fluid tip.
DDA DDB	Pump cavitation; dives more than 3/4 of stroke.	Always	No fluid or valve closed.	Refill supply and open inlet valve.
Material is too cold or thick.			Increase material temperature to reduce viscosity. (See Heat Fluid section in manual 312359.) Shear material with agitation to reduce viscosity.	
Pump inlet check valve not closing.			Clear debris from check valve. Or replace ball, seat, and seal. See Pump Assembly , page 44.	
Feed pump not providing material.			Check feed pump (if used).	
Inlet strainer plugged (if used).			Check and clean strainer. See Pump Assembly , page 44.	
P1A P1B	Pressure low.	Spray, Pump Test, Leak Test	Fluid pressure is below 1000 psi (7 MPa, 70 bar).	Increase main air regulator.
P4R	Pressure high.	Recirculation	Pressure is above maximum advisory limit of 3000 psi (21 MPa, 210 bar) on A side.	Decrease pump air regulator pressure.
P5R	Pressure high.	Recirculation	Pressure is above maximum warning limit of 5200 psi (35.9 MPa, 359 bar) on A side.	Decrease pump air regulator pressure.
P9A	A pump pressure is abnormally low compared to B pump pressure.	Spray	A air motor is icing up causing restriction and lower fluid pressure.	Open the air motor de-ice bleed air controls. Allow ice to melt. Dry compressed air. Heat compressed air. Use a smaller tip.
			A pump is binding.	Repair lower. See Remove Displacement Pump , page 44.
			A motor is hanging up.	Repair air motor. See Remove Air Motor , page 45.
P9B	B pump pressure is abnormally low compared to A pump pressure.	Spray	B air motor is icing up causing restriction and lower fluid pressure.	Open the air motor de-ice bleed air controls. Allow ice to melt. Dry compressed air. Heat compressed air. Use a smaller tip.
			B pump is binding.	Repair lower. See Remove Displacement Pump , page 44.
B3A	Dosing size A advisory	Spray	The fluid dosing size is greater than 35 cc when fast dosing is turned off.	Adjust the B side fluid restriction.
			The fluid dosing size is greater than 20 cc when fast dosing is turned on.	Decrease the air motor velocity with a smaller tip.

Alarm Code	Alarm Problem	When Active	Cause	Solution
B4A	Dosing size A alarm	Spray	The fluid dosing size is greater than 45 cc when fast dosing is turned off.	Adjust the B side fluid restriction.
			The fluid dosing size is greater than 30 cc when fast dosing is turned on.	Decrease the air motor velocity with a smaller tip.
Pump Test (Daily Check Recommended)				
DFA DFB	Pump did not stall against fluid pressure on up stroke only.	Pump Test	Pump piston check valve, piston packings, or dosing valve are not holding fluid pressure.	Flush pump. See Flush , page 14. Recheck. Remove, clean, and repair lower. See Pump Assembly , page 44.
DGA DGB	Pump did not stall against fluid pressure on down stroke only.	Pump Test	Pump inlet check or dose valve is fouled, or damaged.	Remove inlet housing & clean and inspect. See Pump Assembly , page 44.
DEA DEB	Pump does not move in 10 minutes.	Park or Pump Test	Recirculation valves were not opened to allow flow.	Open recirculation valves.
General System Component Alarms				
DJA DJB	Pump motor linear sensor has no signal.	Always	No linear sensor signal from motor.	Swap A and B sensors. Replace sensor if problem follows sensor.
			Linear sensor plugged in while power is on.	Power sprayer off and back on. Do not plug in linear sensor while power is on.
			Bad connection inside fluid control module.	Replace fluid control module. See page 34.
	Pump motor linear sensor is out of range.	Always	Linear sensor is beyond range.	Replace sensor or sensor magnet.
			Sprayer is not properly grounded.	See Grounding , page 11.
DKA DKB	Pump motor reed switch failure; missing signals from one or both switches.	Always	Bad motor cable connections, or bad reed switch.	Swap A and B motor cables. Replace cable if problem persists. Otherwise replace reed sensor assembly.
			Reed switch cable is plugged in while power is on.	Power sprayer off and back on. Do not plug in reed switch cable while power is on.
			Bad connection inside fluid control module.	Replace fluid control module. See page 34.
P6A P6B	Pressure sensor failure; no signal.	Always	Pressure sensor or cable is bad on the A or B side.	Replace sensor and cable assembly. See Pump Assembly , page 44.

Alarm Code	Alarm Problem	When Active	Cause	Solution
V1M	Voltage low control	Always	Voltage dropping below 9 Vdc from power supply.	Change air filter in control filter regulator. See Replace Air Filter Element , page 31.
				Check the pressure setting is 18 psi (0.12 MPa, 1.24 bar) on turbine air regulator.
				Check voltage on information screen.
			Turbine not spinning with air on.	Replace air turbine cartridge. See Alternator Power Supply Control Components , page 38.
N6C	Display has no signal.	Always	No display communication signal.	Check cable connections. Replace display.
			Machine powered down in spray mode.	Press stop button before turning off power.
DLA	A air motor reed switch signal missing advisory.	Always	Reed switch does not see the air motor magnet.	Replace air motor reed switch magnet.
			Reed switches are bad.	Replace air motor reed switch.
			Air motor is icing up.	Prevent air motor icing. See advisory P9A and P9B.
DLB	B air motor reed switch signal missing advisory.	Always	Reed switch does not see the air motor magnet.	Replace air motor reed switch magnet.
			Reed switches are bad.	Replace air motor reed switch.
			Air motor is icing up.	Prevent air motor icing. See advisory P9A and P9B.
DMA	A air motor linear sensor jump advisory.	Always	System ran out of fluid.	Add fluid to the system.
			Linear sensor is bad.	Replace linear sensor.
DMB	B air motor linear sensor jump advisory.	Always	System ran out of fluid.	Add fluid to the system.
			Linear sensor is bad.	Replace linear sensor.
Optional User-Settable Maintenance Warnings				
MAA MAB	Maintain pump	Always, if enabled	Pump usage exceeds user-set limit. Maintenance due.	Service pump. See Pump Assembly , page 44.
MEA MEB	Maintain dosing valve	Always, if enabled	Dosing valve usage exceeds user-set limit. Maintenance due.	Service dosing valve. See Dosing Valve Assembly , page 42.
MG0	Maintain air filter	Always, if enabled	Air filter exceeds user-set limit. Maintenance due.	Service main air filter and control filter regulator. See Replace Air Filter Element , page 31.
P5A P5B	Pressure exceeded alarm limits	Always, if enabled	Pressure exceeded high or low alarm limits for more than 15 seconds.	Adjust pump pressure regulator, change tips, or adjust target set point.

Alarm Code	Alarm Problem	When Active	Cause	Solution
Optional User-Settable Spray Limits				
T5A T5B	Temperature exceeded alarm limits	Always, if enabled	Fluid temperature exceeded high or low alarm limits for more than four minutes.	<p>If fluid temperature is too low, return to circulation mode to increase fluid temperature. Adjust heater set point if needed. See Heat Fluid section in manual 312359.</p> <p>If fluid temperature is too high, lower heater set point, and return circulation mode to cool. See Heat Fluid section in manual 312359.</p> <p>Adjust temperature target set-point. See Heat Fluid section in manual 312359.</p>
P2A P2B	Pressure exceeded advisory limits	Always, if enabled	Pressure exceeded high or low advisory limits for more than 15 seconds.	Same as P5A or P5B.
T2A T2B	Temperature exceeded temperature limits	Always, if enabled	Fluid temperature exceeded high or low limits for more than four minutes.	Same as T5A or T5B.
N4D	Pot life timer expired. Mixed fluid will cure in hoses, mixer, and gun.	Spray	Have not sprayed enough volume to keep fresh mixed fluid in the integration hose, mixer, whip hose, and spray gun.	Spray fluid, or flush. Resets when you leave spray mode. See manual 312359. See Flush , page 14.

Possible Alarms by Mode

The following table outlines the alarms that you may receive while operating the system. The alarms are categorized according to each mode.

Mode	Control Logic	Alarms
Spray	Dosing valves close for startup test; green light blinks.	--
	If fluid pressure is under 1000 psi (7 MPa, 70 bar), STOP.	P1A
	If pumps move (indicating internal leakage), STOP.	FHA, FHB
	If fluid pressure is more than 103% of allowed maximum, air motor shuts off until fluid pressure drops.	None
	If is pressure more than 110% of allowed maximum, STOP.	P4B
	Dosing valve A opens, and dosing valve B cycles to maintain ratio.	--
	A and B blue lights illuminate when dosing valves are operating.	--
	If there is not enough B component to hold ratio, dosing valve A closes momentarily.	R2D
	If A or B component is more than 5% off ratio setpoint, STOP.	R1B, R4B
	If A dose size is too large, STOP.	B4A
	A and B dosing valves close momentarily at each pump changeover	--
Park	Both dosing valves open; A and B blue lights turn on.	--
	User opens circulation valves or sprays gun. When pump reaches bottom stroke the blue light turns off.	--
	If park does not complete in 10 minutes, turn off air to both motors.	DEA, DEB
Circulation	A and/or B dosing valves open and motor air turns on.	--
	If fluid pressure exceeds 3000 psi (21.0 MPa, 210 bar) on the A pump, receive yellow light advisory.	P4A
	If fluid pressure exceeds 5600 psi (39.2 MPa, 392 bar) on the A pump, STOP.	P4A
	If no movement in 10 minutes, turn off air to both motors.	DEA, DEB
Pump Test	Both dosing valves close; green light blinks.	--
	If fluid pressure is under 1000 psi (7.0 MPa, 70 bar), STOP.	P1A, P1B
	If pumps move (indicating leakage) STOP.	FHA, FHB
	Turn on A blue light, open A dosing valve, user opens sampling valve.	--
	Close A dosing valve on upstroke; check for no movement.	DFA
	Close A dose valve on down stroke; check for no movement.	DGA
	Open A dose valve and dispense total of 750 ml material, close valve, turn off blue light.	--
	Repeat for B side.	DFB, DGB, DHB
	If both pumps pass pump test, display shows two beakers of 750ml each.	--
	Batch Dispense Test	User selects total volume desired.
Open A dosing valve, turn on blue light, user opens sampling valve, turn off blue light when complete.		--
Open B dosing valve, turn on blue light, user opens sampling valve, turn off blue light when complete.		--
Display shows volume of A and B components at end of batch dispense test.		--
Valve Test	If fluid pressure is not 1000 psi (7 MPa, 70 bar), STOP.	P1A
	Check for no movement of pumps (stall within 10 seconds).	FHA, FHB

Alarm Code Key

Use the following table as a quick guide to determine alarm codes.

What		Alert		Where	
B	Dose	1	Low	A	Material A
F	Flow	2	Deviation	B	Material B
N	Time	3	Deviation High	C	Controller
P	Pressure	4	High	D	Dosing/Pot life
R	Ratio	5	Limit warning	M	Power or Air supply
T	Temperature	6	Sensor or connection failure	R	Recirculation
V	Voltage	9	Unbalanced		
D	Pump	A	Pump runaway		
		D	Pump diving/cavitation		
		E	Pump time-out		
		F	Pump failed to stall up		
		G	Pump failed to stall down		
		H	Pump failed to stall		
		J	Linear sensor failure		
		K	Directional switch failure		
		M	Linear sensor jump		
M	Maintenance due	A	Pump		
		E	Dosing valve		
		G	Filter		

LED Diagnostic Information

The following LED signals, diagnosis, and solutions are the same for the display module, fluid control module, and USB module. LEDs are located next to the module power cable.

Module Status LED Signal	Diagnosis	Solution
Green on	System is powered up and power supply voltage is greater than 11 Vdc.	-
Yellow	Internal communication in progress	-
Red solid	Hardware failure	Replace display module, fluid control module, or USB module.
Red flashing fast	Uploading software	-
Red flashing slow	Token error	Remove token and upload software token again.

Repair

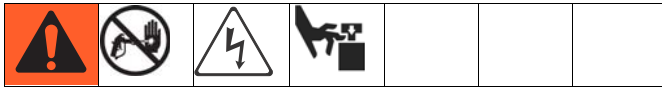

Follow **Shutdown Entire System** procedure, page 18, if service time may exceed pot life time, before servicing fluid components, and before transporting sprayer to a service area.

Replace Air Filter Element

There are two air filters on the system: the inlet air regulator filter on the air controls and the main air inlet manifold filter. Check filters weekly and replace element as needed.

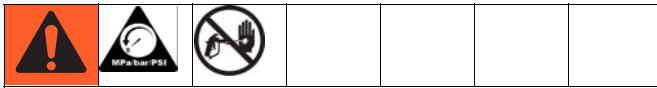

Removing a pressurized air filter bowl could cause serious injury. Do not service air filter until air line is depressurized.

Both Filters

1. Close main air shutoff valve on air supply line and on unit. Depressurize air line.

Control Air Regulator Filter

2. Remove front and rear shrouds (12, 13). Remove four nuts (14) and then shrouds.

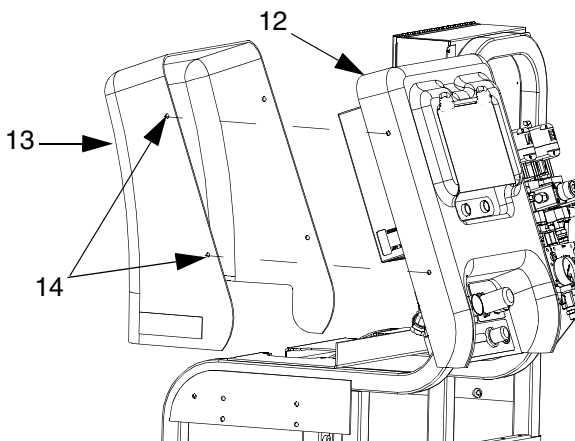

r_312359_313289_16

3. Unscrew filter bowl from inlet air regulator (344).

4. Remove and replace element.

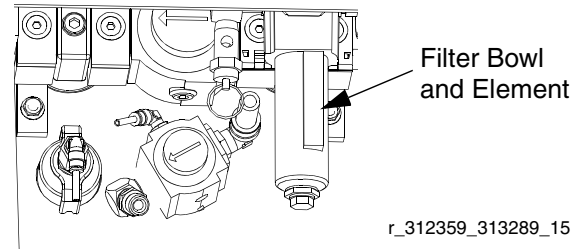
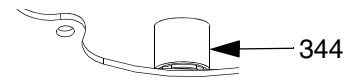

r_312359_313289_15

5. Screw filter bowl on securely.

Main Air Inlet Manifold Filter

2. Unscrew filter bowl from main air inlet manifold (6).
3. Remove and replace filter element (604a). See **Air Inlet Manifold (255762) Parts**, page 77.

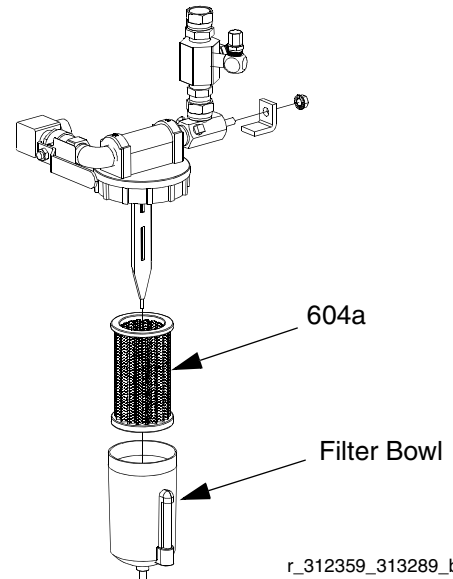

r_312359_313289_b_6

4. Reassemble filter bowl.
5. Replace front and rear shrouds (12, 13) using four nuts (14).

User Interface/Control Box

NOTE:

This section covers all components included in the wall power supply control box option and the intrinsically safe pneumatic power supply control box option.

Remove Shroud

1. Close main air shutoff valve on air supply line and on system.
2. Remove shrouds (12, 13) covering control box. Remove four nuts (14) and front shroud (12) first.

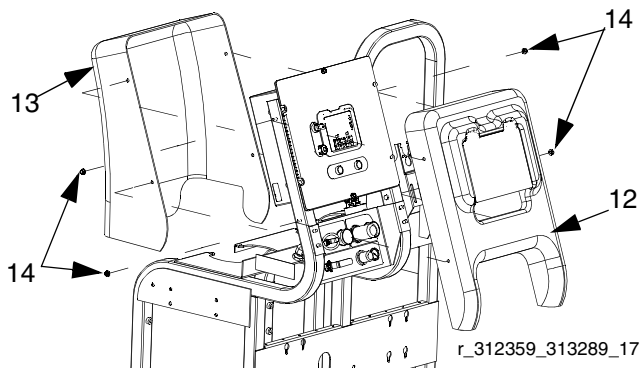

Replace Solenoid Module

Follow this procedure to replace a single solenoid

1. Remove shroud. See **Remove Shroud**.
2. Disconnect power.
3. Remove four nuts (4); leave two nuts on left side of panel tight. Open front panel of control box (11).

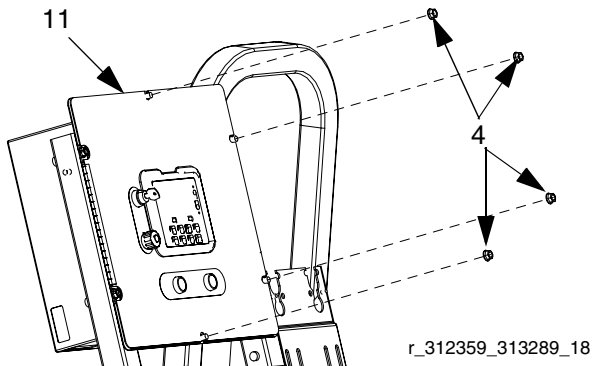

4. Disconnect solenoid cable connectors (242) from solenoids.

5. Disconnect air tubing from solenoid manifold block (209).

NOTE:

If your sprayer is an intrinsically safe model, you will need to remove the alternator air regulator from the solenoid module. See **Replace Alternator Regulator**, page 39, for removal instructions.

6. Remove two screws (210).

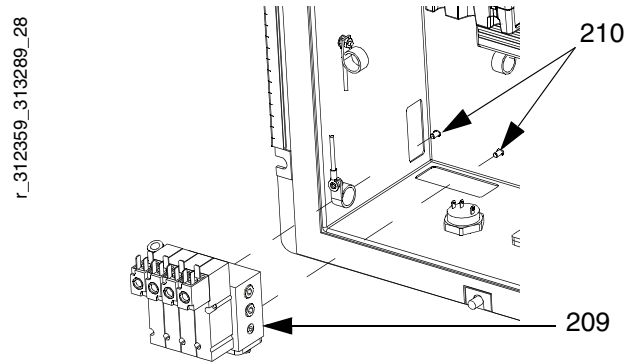

7. Remove and replace solenoid (209).
8. Reassemble screws (210) and solenoid cable connectors (242).

NOTE:

From left to right, solenoid functions are as follows:

- Dosing valve A (DVA) (normally open)
- Dosing valve B (DVB) (normally open)
- Pump A (PA) (normally closed)
- Pump B (PB) (normally closed)

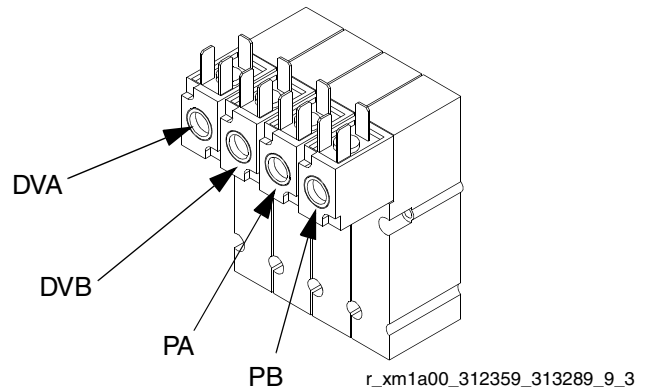

Update USB Module Software

1. Remove shroud. See **Remove Shroud**.
2. Use software token 16A265. See Graco Control Architecture™ Module Programming manual for instructions.

NOTE: Upgrade all modules in the system to the software version on the token, even if you are replacing only one or two modules. Different software versions may not be compatible.

All data in the module may be reset to factory default settings. Record all settings and user preferences before the upgrade, for ease of restoring them following the upgrade.

The latest software version for each system can be found at Tech Support at www.graco.com.

Replace USB Module

1. Remove shroud. See **Remove Shroud**.
2. Disconnect power.
3. Remove four nuts (4); leave two nuts on left side of panel tight. Open front panel of control box (11).
4. Disconnect CAN cables and USB cable from USB module (219).
5. Remove two mounting screws from USB module and remove module from base.

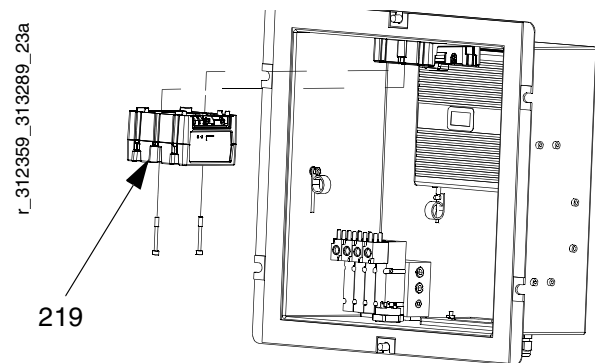

6. Follow steps in reverse order to install new USB module.
7. Load software. See **Update USB Module Software**.

Update Fluid Control Module (FCM) Software

1. Remove shroud. See **Remove Shroud**.
2. Use software token 16A265. See Graco Control Architecture™ Module Programming manual for instructions.

NOTE: Upgrade all modules in the system to the software version on the token, even if you are replacing only one or two modules. Different software versions may not be compatible.

All data in the module may be reset to factory default settings. Record all settings and user preferences before the upgrade, for ease of restoring them following the upgrade.

The latest software version for each system can be found at Tech Support at www.graco.com.

Replace Fluid Control Module (FCM)

NOTE:

The USB module does not need to be removed prior to replacing the FCM.

1. Remove shroud. See **Remove Shroud**.
2. Disconnect power.
3. Remove four nuts (4); leave two nuts on left side of panel tight. Open front panel of control box (11).
4. Remove all cables from FCM (218). Take note of cable locations.
5. Loosen four mounting screws (235).

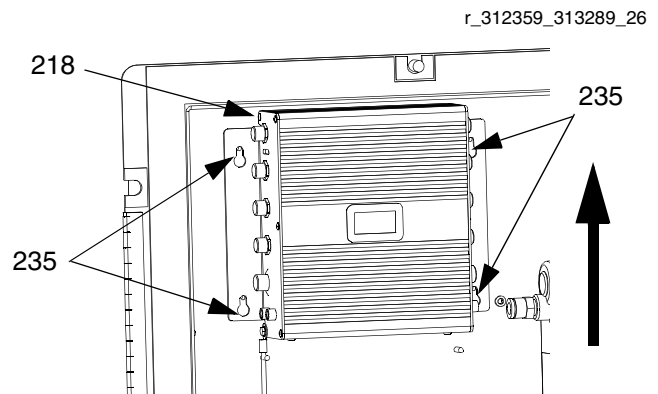

6. Slide FCM up and out of keyhole slots.
7. Follow steps in reverse order to install new FCM.
8. Load software. See **Update Fluid Control Module (FCM) Software**.
9. Most of the system configuration is stored in the FCM. Use the display to change the configuration to the values in the old FCM. See XM plural-component operation manual for instructions.

Replace Alarm

1. Remove shroud. See **Remove Shroud**.
2. Disconnect power.
3. Remove four nuts (4); leave two nuts on left side of panel tight. Open front panel of control box (11).
4. Disconnect alarm wires from alarm (217).
5. Unscrew alarm (217) and replace.

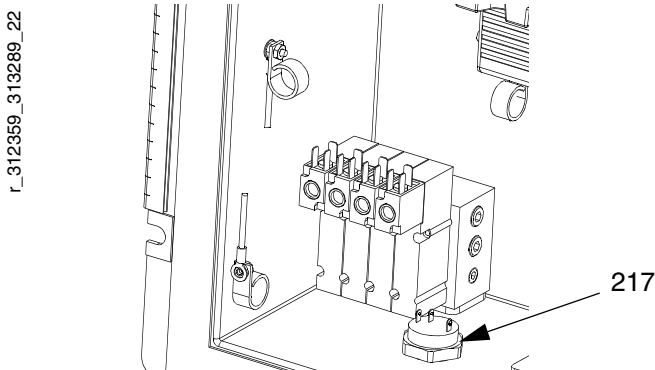

6. Screw in new alarm. Reconnect alarm wires. Refer to **Electrical Schematics**, page 47.
7. Reassemble air control front shroud (12).

Display

Upgrade Software

Do not upgrade software when an explosive gas atmosphere may be present.							

NOTICE
To avoid damaging circuit board, wear a grounding strap.

Use software token 16A265. See Graco Control Architecture™ Module Programming manual for instructions.

NOTE: Upgrade all modules in the system to the software version on the token, even if you are replacing only one or two modules. Different software versions may not be compatible.

All data in the module may be reset to factory default settings. Record all settings and user preferences before the upgrade, for ease of restoring them following the upgrade.

The latest software version for each system can be found at Tech Support at www.graco.com.

1. Remove shroud. See **Remove Shroud**.
2. Disconnect power.
3. Remove four nuts (4); leave two nuts on left side of panel tight. Open front panel of control box (11).
4. Remove four screws (204f) and then access cover (204e).

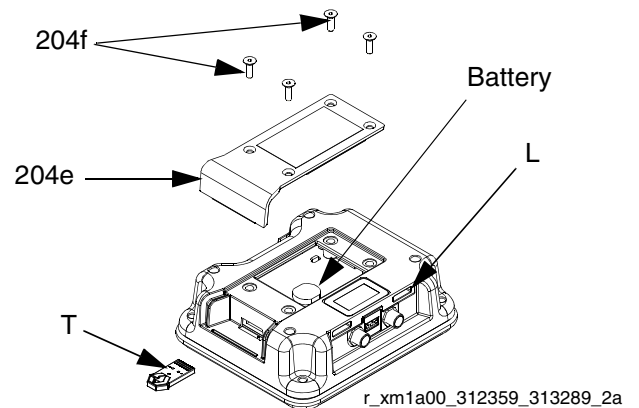



5. Insert and press token (T) firmly into slot.

NOTE:

There is no preferred orientation of token.

6. Turn power on.
7. The red indicator light (L) will flash until new software is completely loaded.
8. Turn power off.
9. Remove token (T).
10. Reassemble access cover (204e) and screws (204f).

Replace Display Battery

						
Do not replace battery when an explosive gas atmosphere may be present.						

NOTICE
To avoid damaging circuit board, wear a grounding strap.

1. Perform steps 1-4 under **Upgrade Software** section, page 35.
2. Use a flat head screwdriver to pry out old battery.

Remove Old Battery

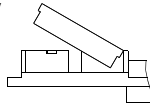

Insert New Battery

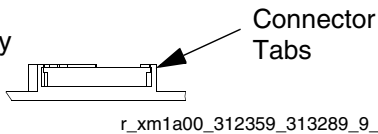

r_xm1a00_312359_313289_9_8a

3. Replace with new battery. Ensure battery fits under connector tabs before snapping other end in place.

NOTE:
Use only Panasonic CR2032 batteries for replacement.

4. Reassemble access cover (204e) and screws (204f).

Replace Display

NOTE: Order kit 257484 for replacement.

NOTICE
To avoid damaging circuit board, wear a grounding strap.

1. Remove shroud. See **Remove Shroud**.
2. Disconnect power.
3. Remove four nuts (4); leave two nuts on left side of panel tight. Open front panel of control box (11).
4. Disconnect CAN cable from display module.
5. Remove four screws (204b) from rear display panel (204c) while holding front display panel (204d) in place.

NOTE:
To ease removal process use clear tape to hold front display panel (204d) in place.

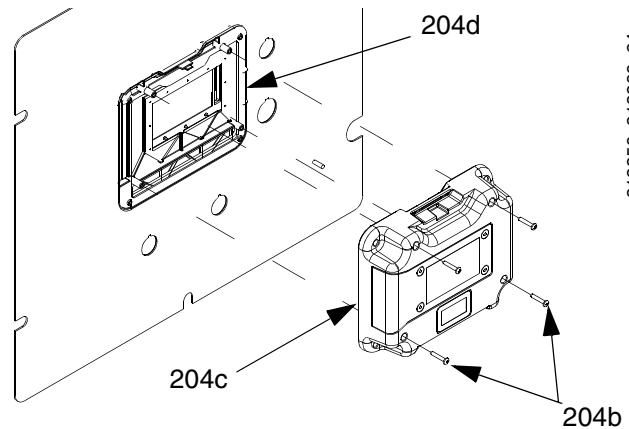

6. Remove rear display panel (204c) and disconnect display cable and key switch cable (239) from circuit board.

- Remove front display panel (204d) and gasket (204g).

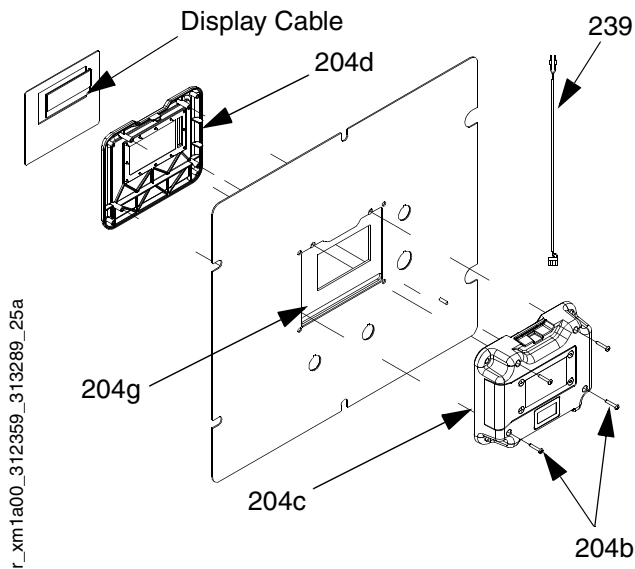

- Discard old display assembly.
- Place new front display panel (204d) and gasket (204g) on front panel of control box (11).

NOTE:

To ease installation process use clear tape to hold front display panel in place.

- Carefully connect display cables and key switch cable to new circuit board.
- Install new rear display panel (204c) and secure with four screws (204b). Ensure key switch cable protrudes from opening in top of display module.
- Install access cover and screws. Apply warning label to access cover.
- Reconnect CAN cable to display module.
- Reconnect power.
- Load software. See **Upgrade Software**, 35.
- Replace shroud.
- Configure system settings as they were set on old display. See XM Plural-Component Operation manual 312359 for instructions.

Replace Front Panel

See **Replace Display**, page 36, for instructions

Wall Power Supply Control Components

Replace Power Supply Module

- Remove shroud. See **Remove Shroud**.
- Disconnect main power.
- Remove four nuts (4); leave two nuts on left side of panel tight. Open front panel of control box (11).
- Disconnect incoming power cable connections to power supply module and ground lead (260) from control box.
- Disconnect power supply cable (272) from FCM (218).
- Remove four screws (273) holding power supply module (270) bracket in place.

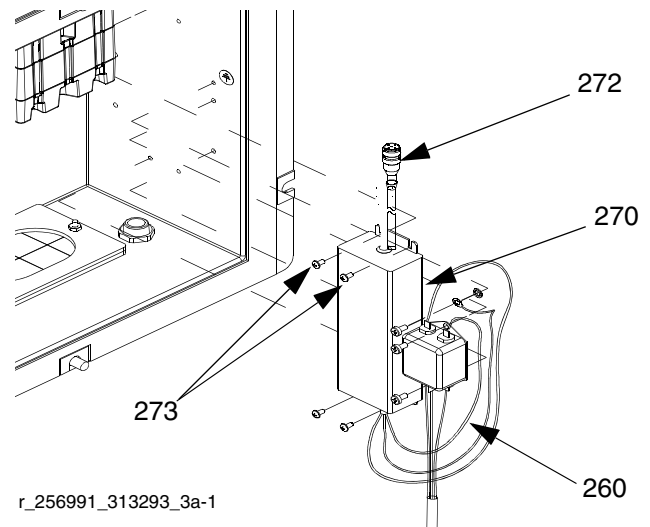

- Remove and replace power supply module (270).
- Follow steps in reverse order to install new power supply module.

Alternator Power Supply Control Components

Alternator Module Repair

Alternator Repair Kit 257147 is available to replace turbine bearings.

1. Remove shroud. See **Remove Shroud**.
2. Disconnect main power.
3. Remove four nuts (4); leave two nuts on left side of panel tight. Open front panel of control box (11).
4. Disconnect output power cable connections from alternator module and ground lead from control box.
5. Disconnect power supply cables from FCM, USB, and display.

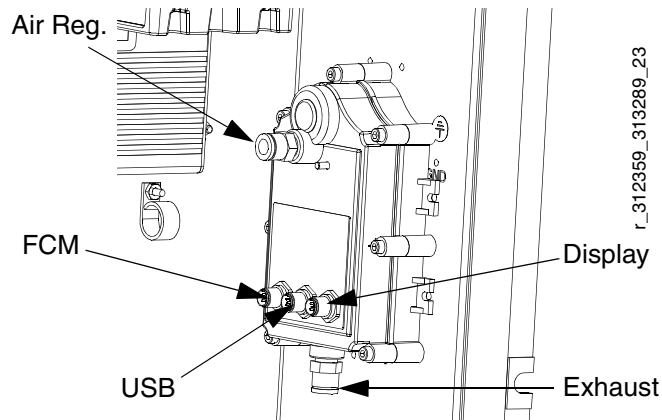

6. Disconnect air regulator air line and exhaust air line.
7. Remove four screws (263) from mounting to remove alternator from control box.

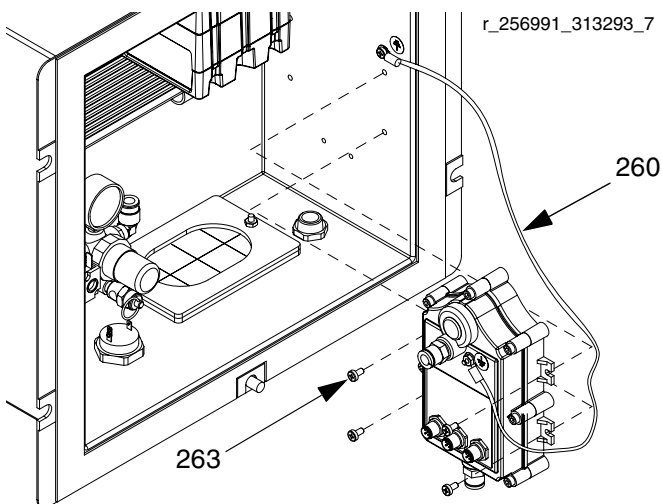

8. Remove seven screws (708) to separate alternator housings.
9. Replace turbine (704) if necessary. Lightly lubricate turbine o-ring to ease alternator housing reassembly.

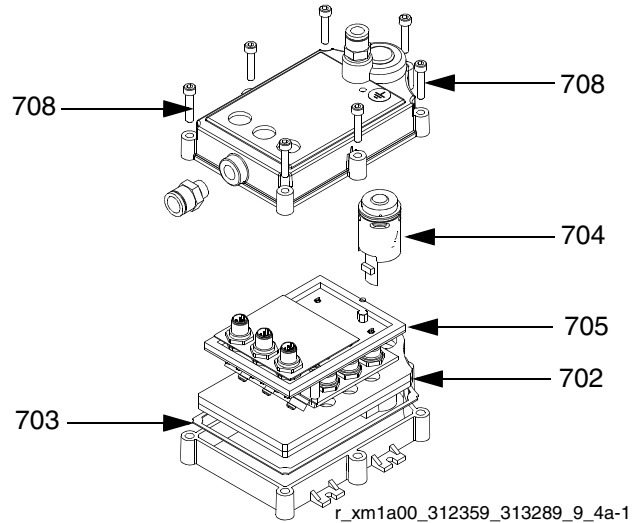

10. Replace gasket (702) and/or circuit board assembly (705) if damaged.
11. Follow steps in reverse order to reassemble alternator regulator assembly and to reconnect power cables and air lines. Refer to **Electrical Schematics**, page 47.

NOTE:

Avoid causing a kink in the flexible circuit board when you reconnect the circuit board assembly (705).

12. Start machine. Check control voltage on Alarm information screen. Voltage should be between 10-14 Vdc.

Replace Alternator Regulator

1. Remove shroud. See **Remove Shroud**, page 32
2. Disconnect main power.
3. Remove four nuts (4); leave two nuts on left side of panel tight. Open front panel of control box (11).
4. Disconnect supply air line from alternator assembly (265).

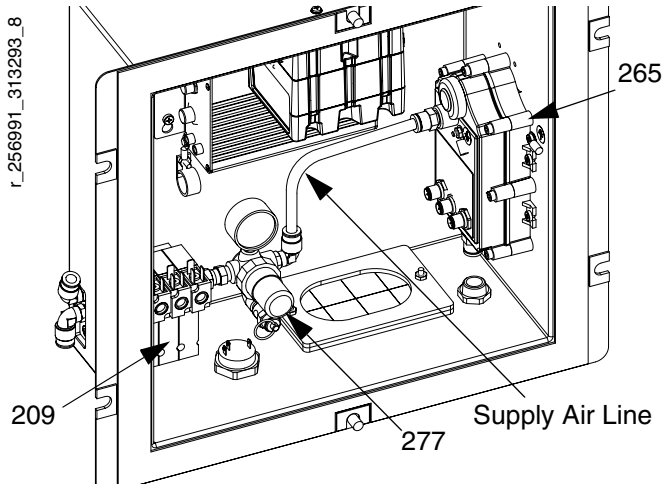

5. Loosen air regulator swivel fitting (276) and remove from solenoid module (209).

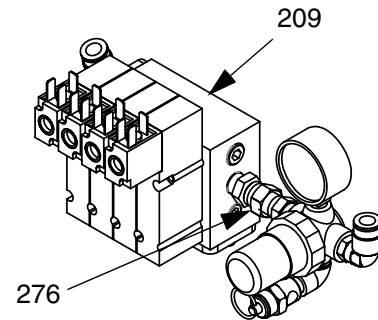

6. Repair or replace alternator regulator parts as necessary. See **Alternator Assembly**, page 72, for repair parts. Replace air regulator swivel fitting (276).
7. Set regulator to 18 +/- 1 psi (12.6 +/- 10 kPa, 1.26 +/- 0.07 bar).
8. Start machine. Check voltage on the alarm information screen. Voltage should be between 10-14 volts.

Air Controls

Remove Air Control Assembly

1. Remove shroud. See **Remove Shroud**, page 32.
2. Disconnect air motor air lines and system air line.
3. Remove four nuts (7) from front of air control bracket (319).
4. Pull out assembly.
5. Follow steps in reverse order to reinstall air control assembly.

Replace Solvent Pump Ball Valve

1. Remove shroud. See **Remove Shroud**, page 32.
2. Disconnect air motor air lines and system air line.
3. Remove four nuts (7) from front of air control bracket (319).
4. Pull out assembly.
5. Remove two nuts (330) from front of air control bracket (319).
6. Disconnect air line (332) running to ball valve assembly (326).
7. Replace with new ball valve assembly. See **Air Controls Module (255761) Parts**, page 74.
8. Follow steps in reverse order to reassemble.

Replace Solvent Air Regulator

1. Remove shroud. See **Remove Shroud**, page 32.
2. Disconnect air motor air lines and system air line.
3. Remove four nuts (7) from front of air control bracket (319).
4. Pull out assembly.
5. Remove regulator nut (331), and disconnect air lines (332, 333) running to regulator (325).
6. Remove regulator assembly and replace with new. See **Air Controls Module (255761) Parts**, page 74.
7. Follow steps in reverse order to reassemble.

Replace System Air Regulator

1. Remove shroud. See **Remove Shroud**, page 32.
2. Disconnect air motor air lines and system air line.
3. Remove four nuts (7) from front of air control bracket (319).
4. Pull out assembly.
5. Remove regulator nut (340) and disconnect system air line.
6. Remove screws from quick clamps and open clamps (342b, 342c) at hinge.
7. Remove regulator assembly (345) and replace with new. See **Air Controls Module (255761) Parts**, page 74.
8. Follow steps in reverse order to reassemble.

Replace Solenoid Inlet Air Regulator

1. Remove shroud. See **Remove Shroud**, page 32.
2. Disconnect air motor air lines and system air line.
3. Remove four nuts (7) from front of air control bracket (319).
4. Pull out assembly.
5. Disconnect air line.
6. Remove gauge from block (343).
7. Remove screws from quick clamps (342a, 342b) holding air regulator assembly (344) in place.
8. Open clamps (342a, 342b) at hinge and pull apart from block (343).
9. Remove regulator assembly (344) and replace with new. See **Air Controls Module (255761) Parts**, page 74.
10. Follow steps in reverse order to reassemble.
11. Set new air pressure regulator to 80-85 psi.(0.55-0.58 MPa, 5.5-5.8 bar).

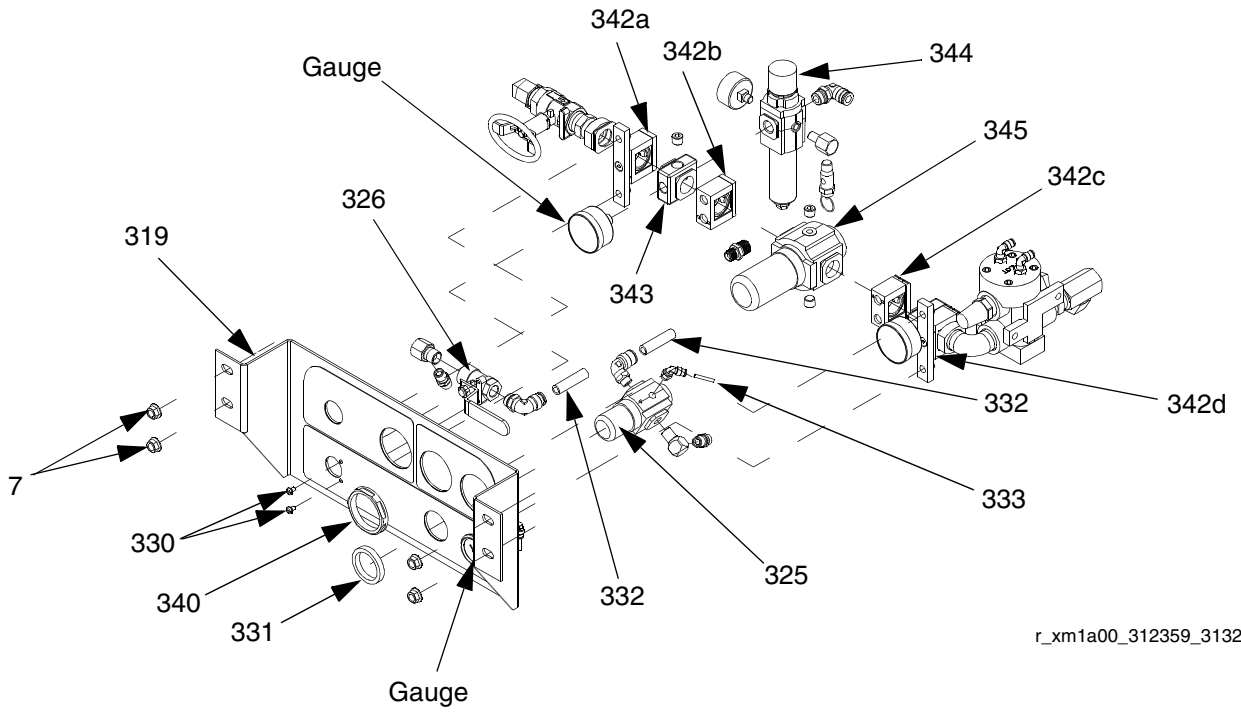

r_xm1a00_312359_313289_9_9

Fluid Control Assembly



Dosing Valve Assembly

1. Follow **Pressure Relief Procedure**, page 12.
2. Disconnect all fluid lines from dosing valve assembly (8).
3. Remove three bolts (16) on back of each dosing valve (501) from bracket.
4. Unscrew dosing valve housing seats from adapters on mix manifold.

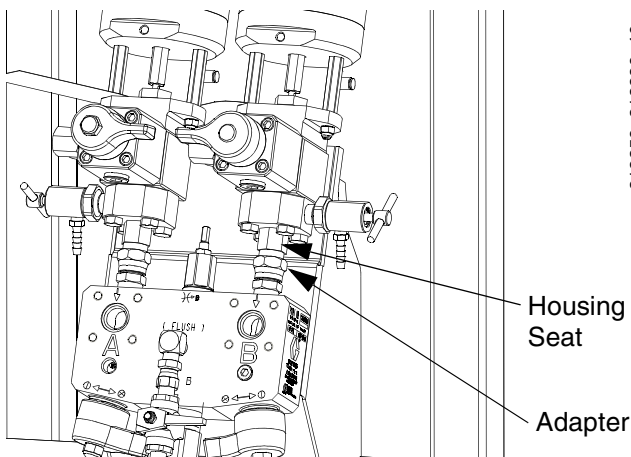

5. Disconnect RTD (506) from cord grip. Disconnect pressure sensor (507) and fluid line adapter from each dosing valve (501).

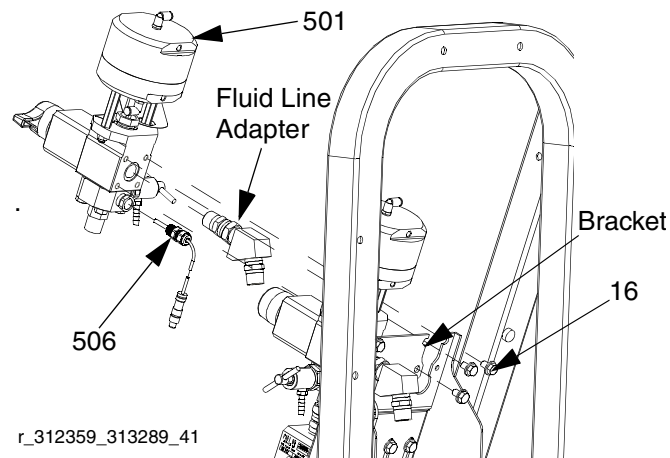

6. Remove dosing valves. See manual 313342 for dosing valve service and repair instructions.
7. Follow steps in reverse order to reassemble dosing valve assembly.

Mix Manifold Assembly

1. Follow **Pressure Relief Procedure**, page 12.
2. Disconnect fluid line and solvent lines from mix manifold assembly.
3. Loosen four bolts securing mix manifold (508) to bracket.

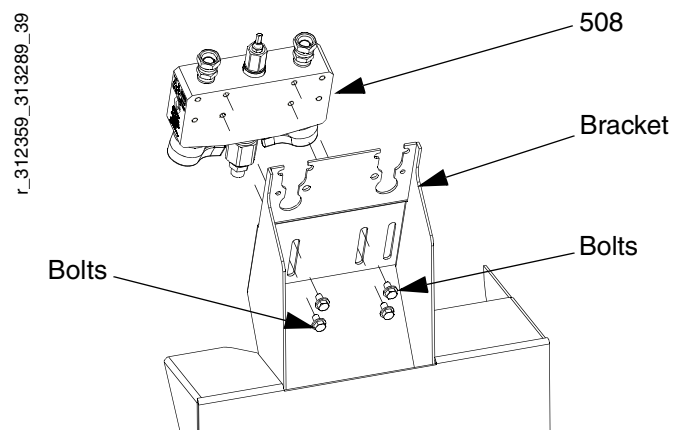

4. Unscrew dosing valve housing seats from adapters on mix manifold.
5. Remove four bolts securing mix manifold (508) to bracket.
6. Remove mix manifold assembly (508) from bracket. See manual 312749 for mix manifold service and repair instructions.
7. Follow steps in reverse order to reassemble mix manifold assembly.

Sensors

Replace Fluid Pressure Sensor

1. Close main air shutoff valve on air supply line and on system.
2. Relieve fluid pressure. See **Pressure Relief Procedure**, page 12.
3. Open control box cover. See **User Interface/Control Box**, page 32.
4. Disconnect pressure sensor (507) from FCM (218).
5. Disconnect fluid pressure sensor (507) from dosing valve (501).

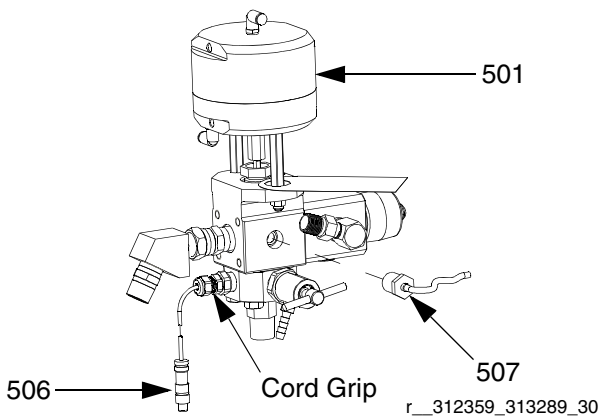

6. Replace with new fluid pressure sensor, and reconnect pressure sensor to FCM.

Temperature (RTD) Sensor

1. Close main air shutoff valve on air supply line and on system.
2. Relieve fluid pressure. See **Pressure Relief Procedure**, page 12.
3. Open control box cover. See **User Interface/Control Box**, page 32.
4. Disconnect temperature sensors (506) from FCM (218).

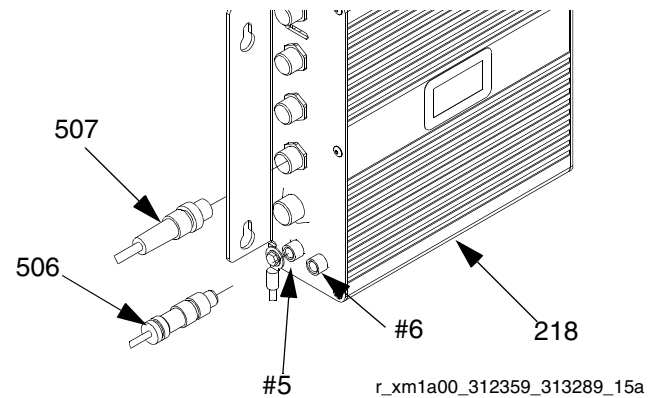

5. Remove RTD (506) cable from cord grip.
6. Replace with new temperature (RTD) sensor.
7. Reassemble RTD cable (506) and cord grip.
8. Connect temperature (RTD) sensor to FCM connector #5. Do not use connector #6.
9. Close control box cover.

Pump Assembly



Prior to servicing the pump assembly you must first remove either the entire pump assembly or the displacement pump and air motor individually.

Remove Pump Assembly

1. Follow **Pressure Relief Procedure**, page 12.
2. Close ball valve on hopper outlet assembly.
3. Disconnect displacement pump from fluid inlet assembly.
 - *50:1 Pump*: disconnect reducer bushing fitting from swivel fitting on fluid inlet assembly.
 - *70:1 Pump*: disconnect reducing swivel from fluid inlet assembly.

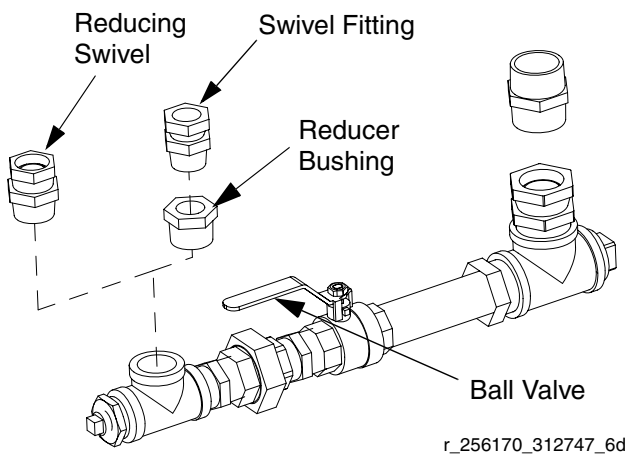

NOTE:

Refer to the Double Wall Hopper manual 312747 to service or repair the fluid inlet assembly.

4. Disconnect air motor.
 - a. Disconnect sensor cable, air line, and ground wire from air motor.
 - b. Remove mounting screws (4) and washers (3) holding air motor (2) to mounting bracket. See illustration in **Remove Air Motor** section.

5. Remove pump assembly by lift ring on air motor.

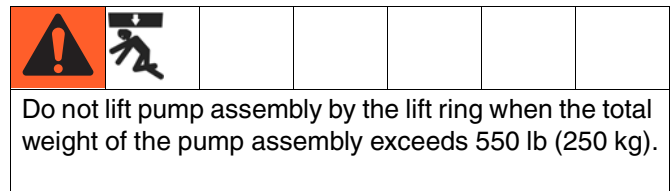

6. Refer to Xtreme Displacement Pump manual 311762 to service or repair the displacement pump. Refer to NXT Air Motor manual 311238 to service or repair the air motor.
7. Follow steps in reverse order to reinstall pump assembly.

Remove Displacement Pump

Follow these instructions for removing only the displacement pump; the air motor will remain installed.

1. Follow **Pressure Relief Procedure**, page 12.
2. Disconnect displacement pump from fluid inlet assembly. See steps 2 and 3 under **Remove Pump Assembly**, page 44.
3. Remove clip (133), and slide coupling cover (134) up to remove coupling (132).

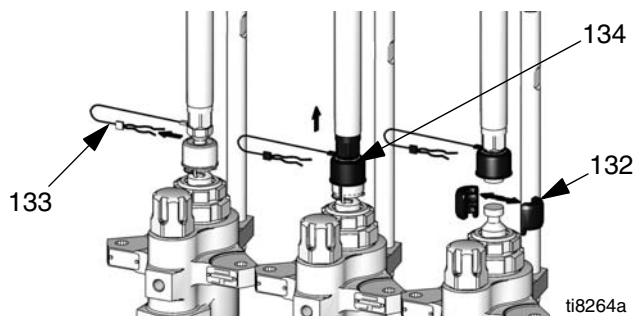

- Use a wrench to hold the tie rod flats to keep the rods from turning. Unscrew the nuts (129) from the tie rods (128) and carefully remove the displacement pump (66 or 67).

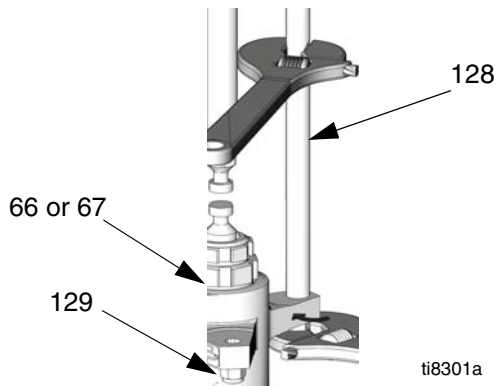

- Refer to the Xtreme Displacement Pump manual 311762 to service or repair the displacement pump.
- Follow steps in reverse order to reinstall displacement pump.

Remove Air Motor

- Follow **Pressure Relief Procedure**, page 12.
- Disconnect displacement pump from air motor. See steps 2 and 3 under **Remove Displacement Pump**, page 44.
- Disconnect sensor cable, air line, and ground wire from air motor.
- Remove mounting screws (4) and washers (3) holding air motor (2) to mounting bracket.

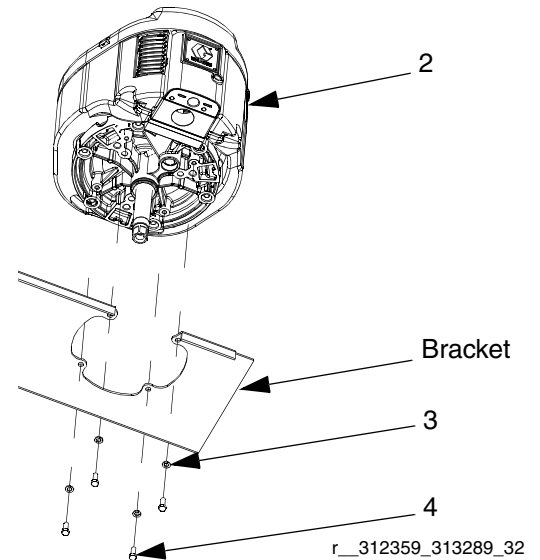

- Refer to NXT Air Motor manual 311238 to service or repair the air motor.
- Follow steps in reverse order to reinstall air motor.

Solvent Pump

1. Follow **Pressure Relief Procedure**, page 12.
2. Disconnect fluid line (140) and air lines (107, 126) from solvent pump.
3. Remove four screws (106) that attach solvent pump (103) to bracket (138) and remove solvent pump.

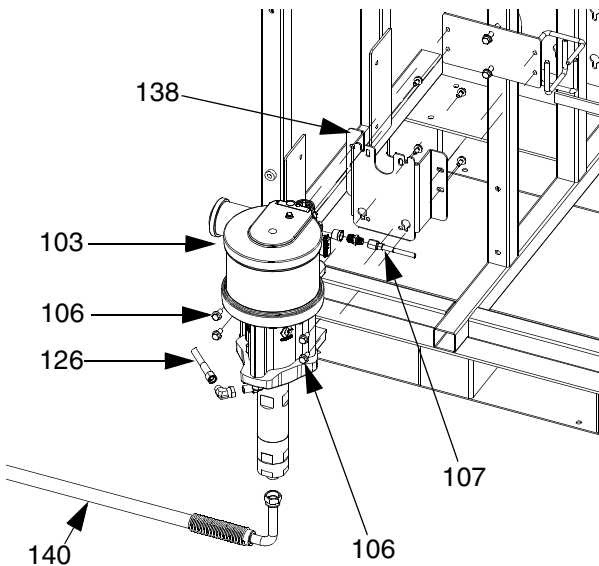

r_312359_313289_22a-1

4. Refer to Merkur Pump Assembly manual 312794 to service or repair solvent pump.
5. Follow steps in reverse order to reinstall solvent pump.

Fluid Heaters

NOTE:

Wiring for explosion-proof heaters (245863) is not provided. See Viscon HP heater manual 309524 for wiring, repair, and parts information for explosion-proof heaters.

Service and Repair

1. Follow **Pressure Relief Procedure**, page 12.
2. Disconnect fluid lines and electrical wiring from fluid heater.
3. Refer to Viscon HP heater manual 309524 to service or repair heater.
4. Reconnect fluid lines and electrical wiring.

Replace

1. Follow steps 1 through 2 above.
2. Loosen four mounting screws (X), lock washers (Y), and plain washers (127) on back of heater (90). Slide heater up and remove from mounting plate.

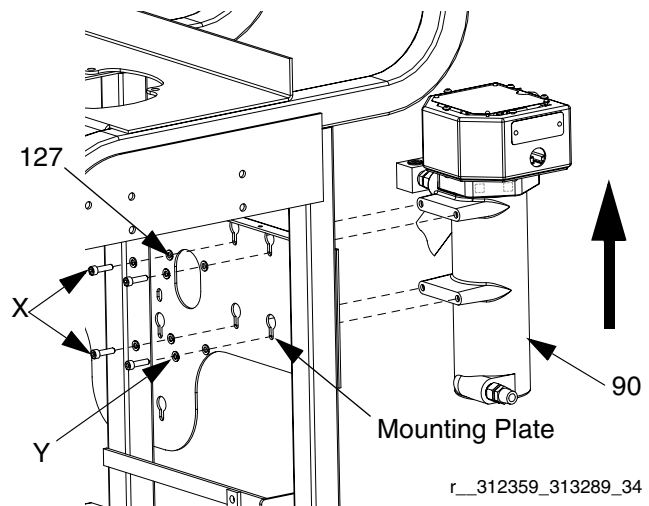

r_312359_313289_34

3. Replace heater. Follow steps in reverse order to install new heater.

Electrical Schematics

Simplified Electrical Schematic, XM Sprayer with Alternator

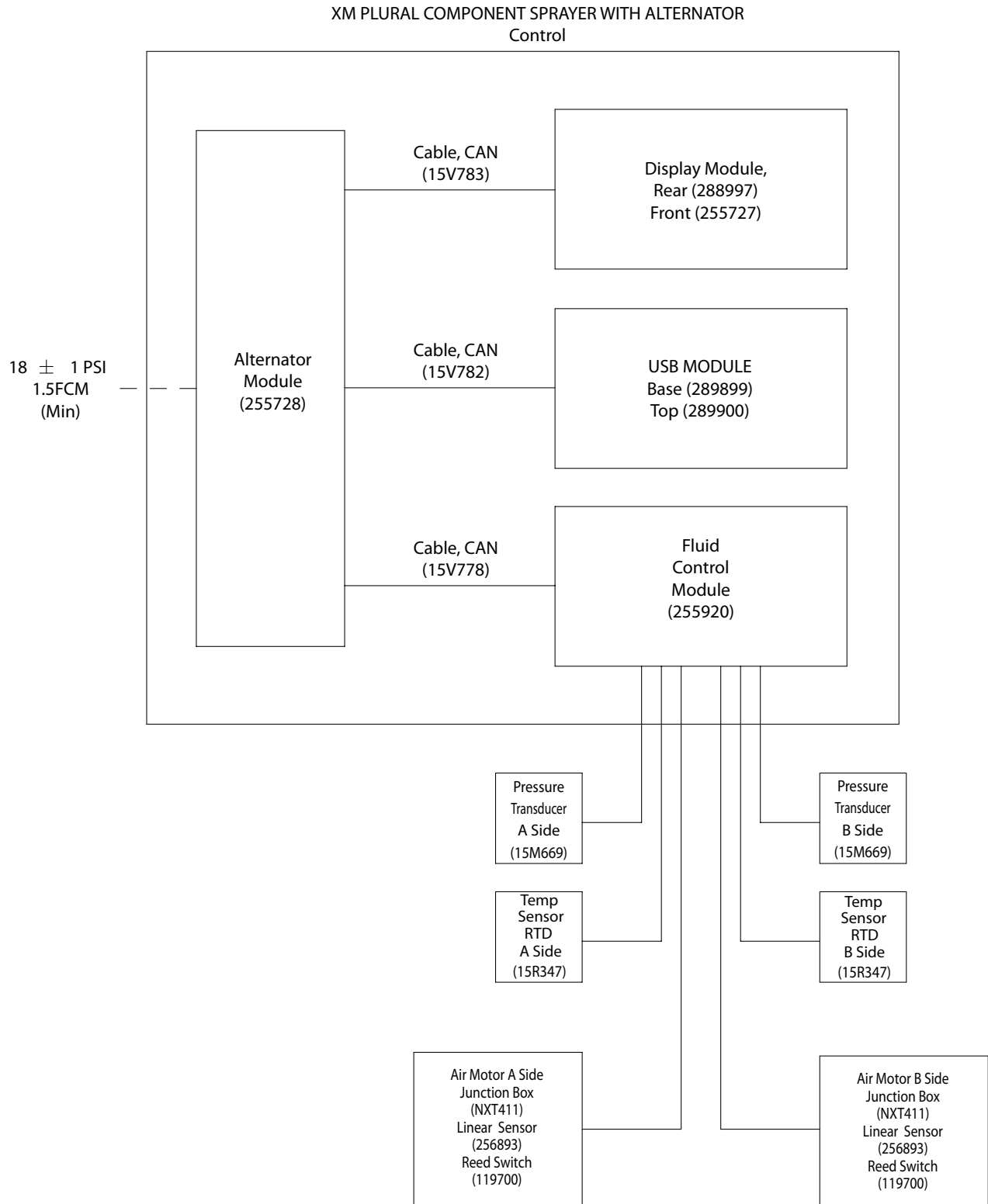

Simplified Pneumatic Schematic, XM Sprayer with Alternator

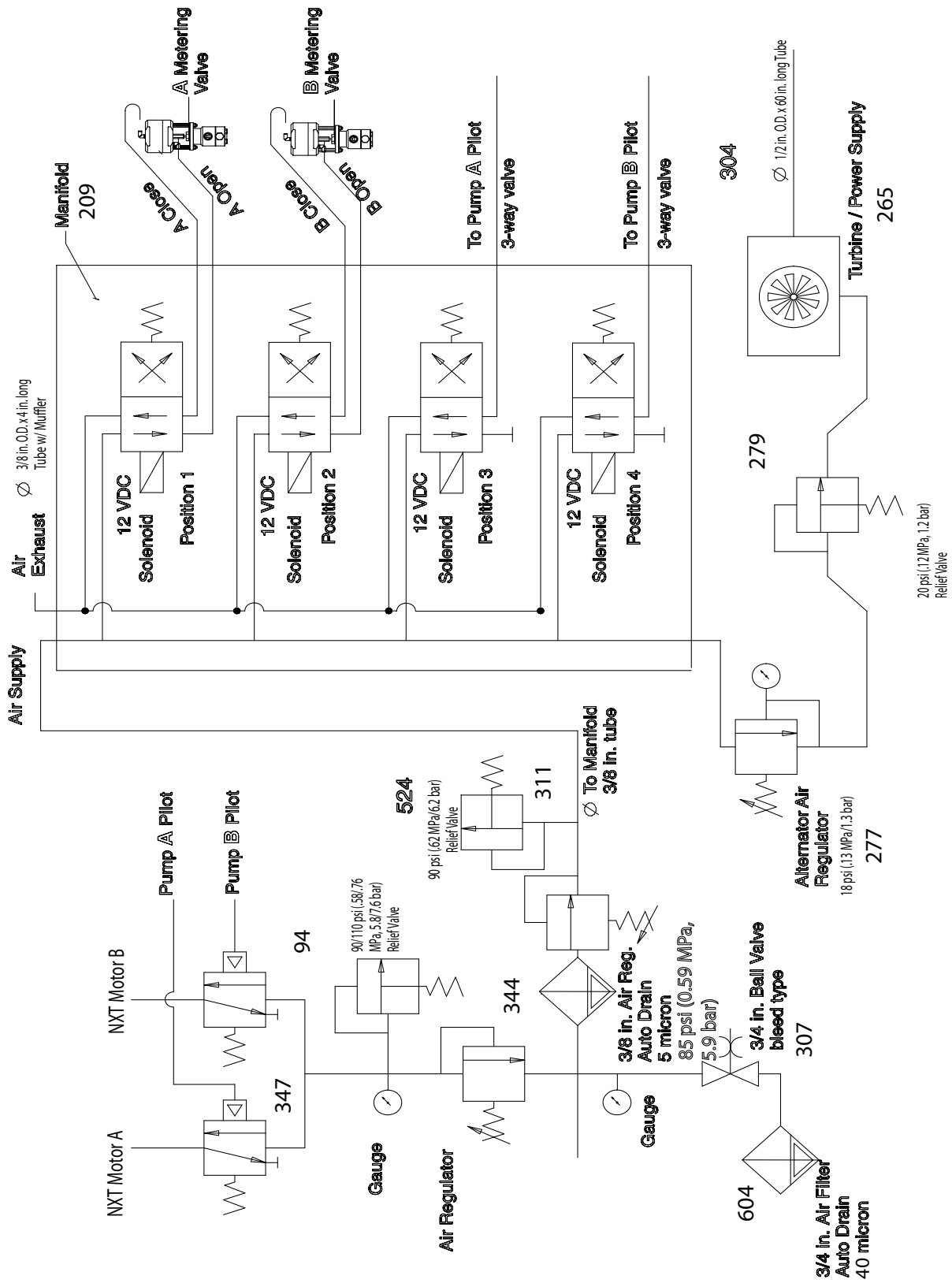

Detailed Electrical Schematic, XM Sprayer with Alternator (page 1)

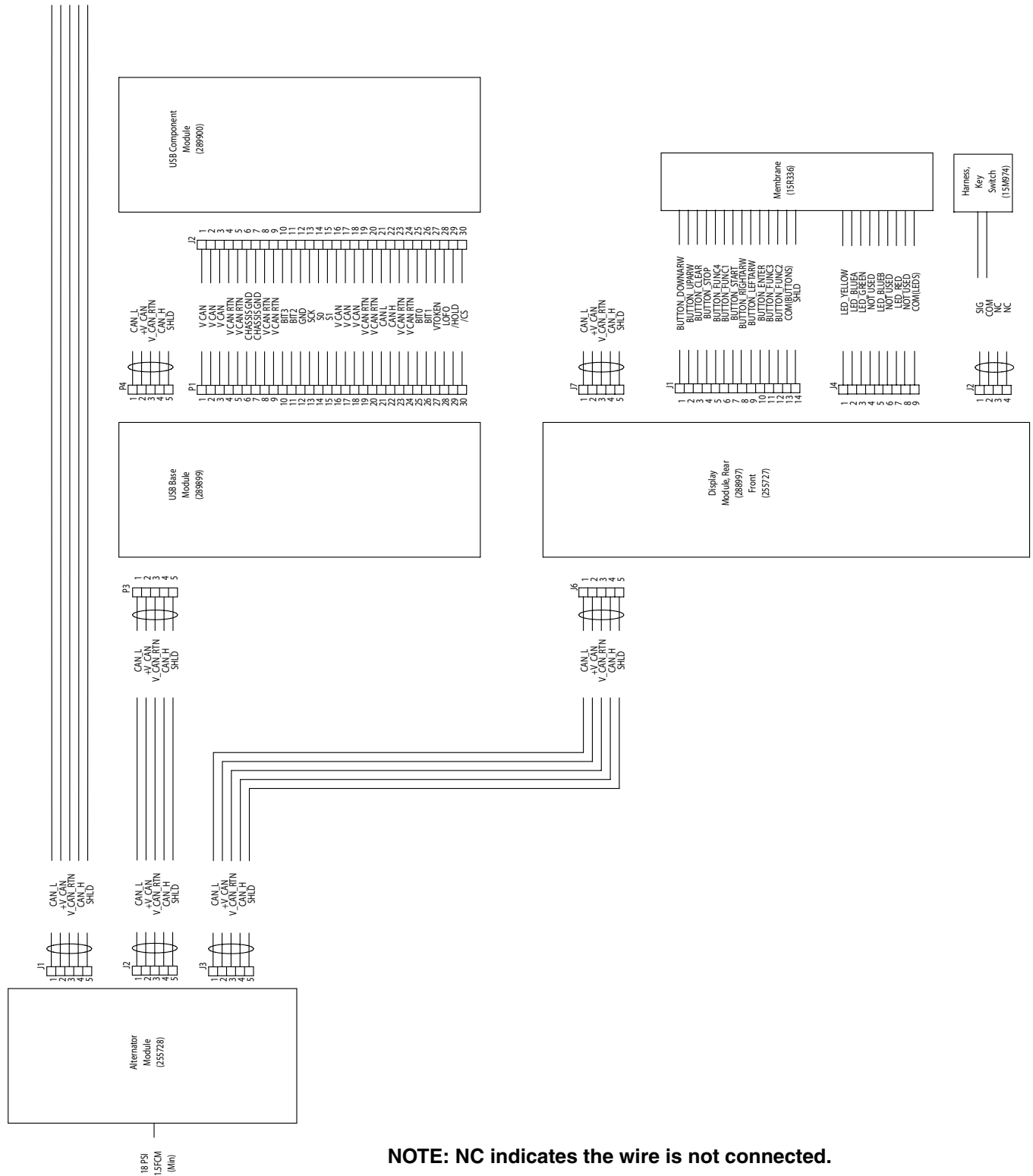

Detailed Electrical Schematic, XM Sprayer with Alternator (page 2)

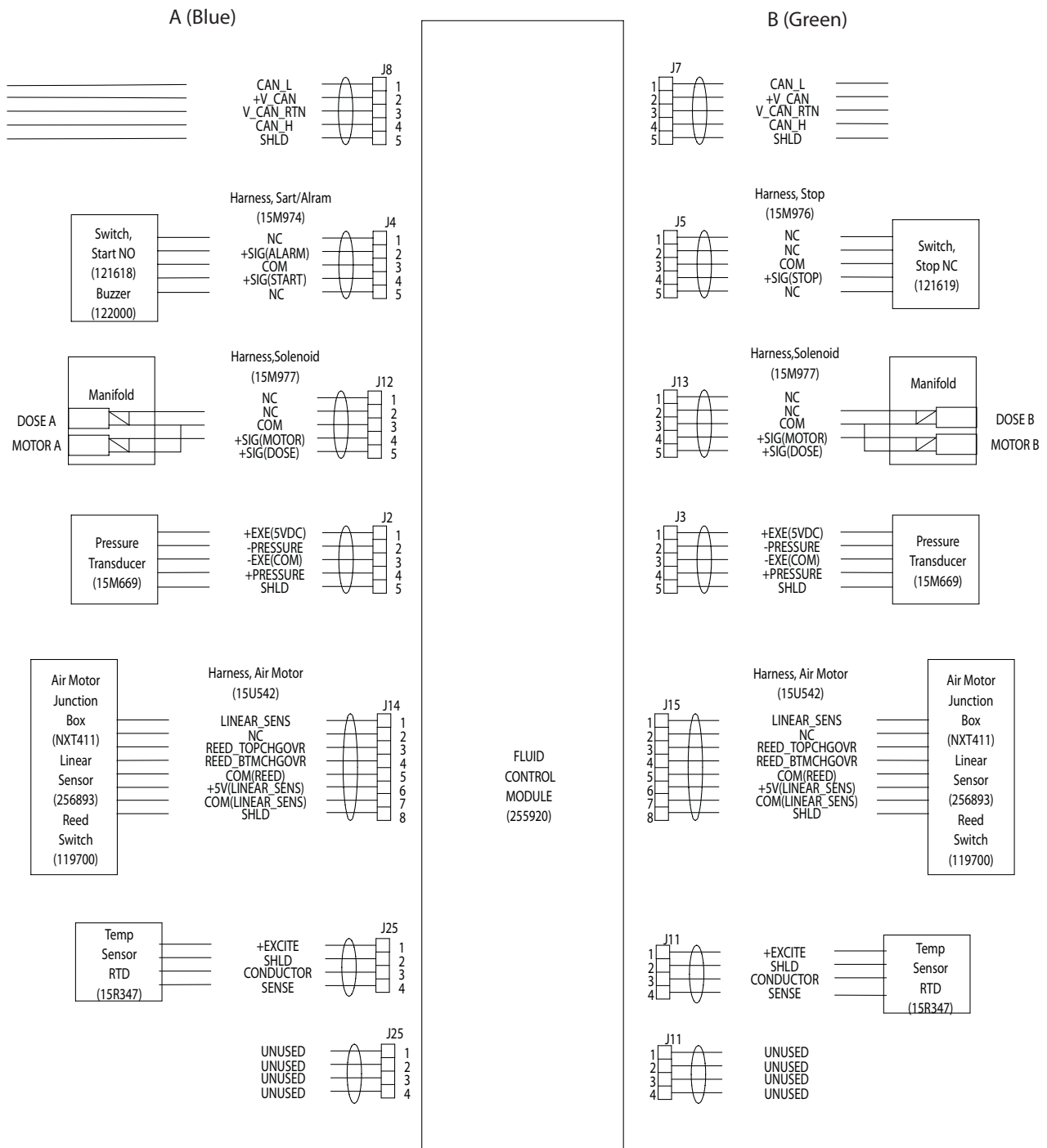

NOTE: NC indicates the wire is not connected.

Simplified Electrical Schematic, XM Sprayer with Wall Power

XM PLURAL COMPONENT SPRAYER WITH WALL POWER
Control

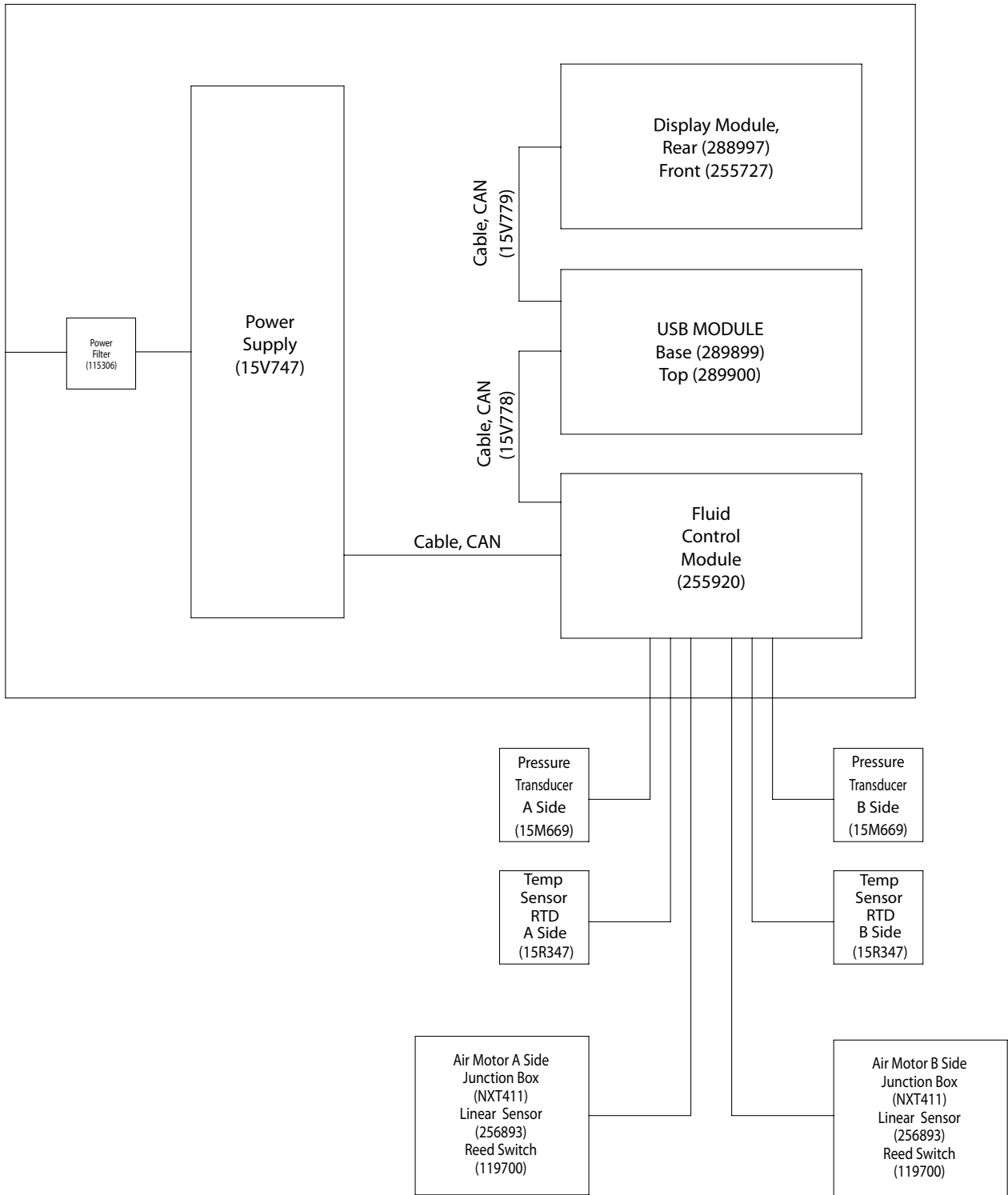

Simplified Pneumatic Schematic, XM Sprayer with Wall Power

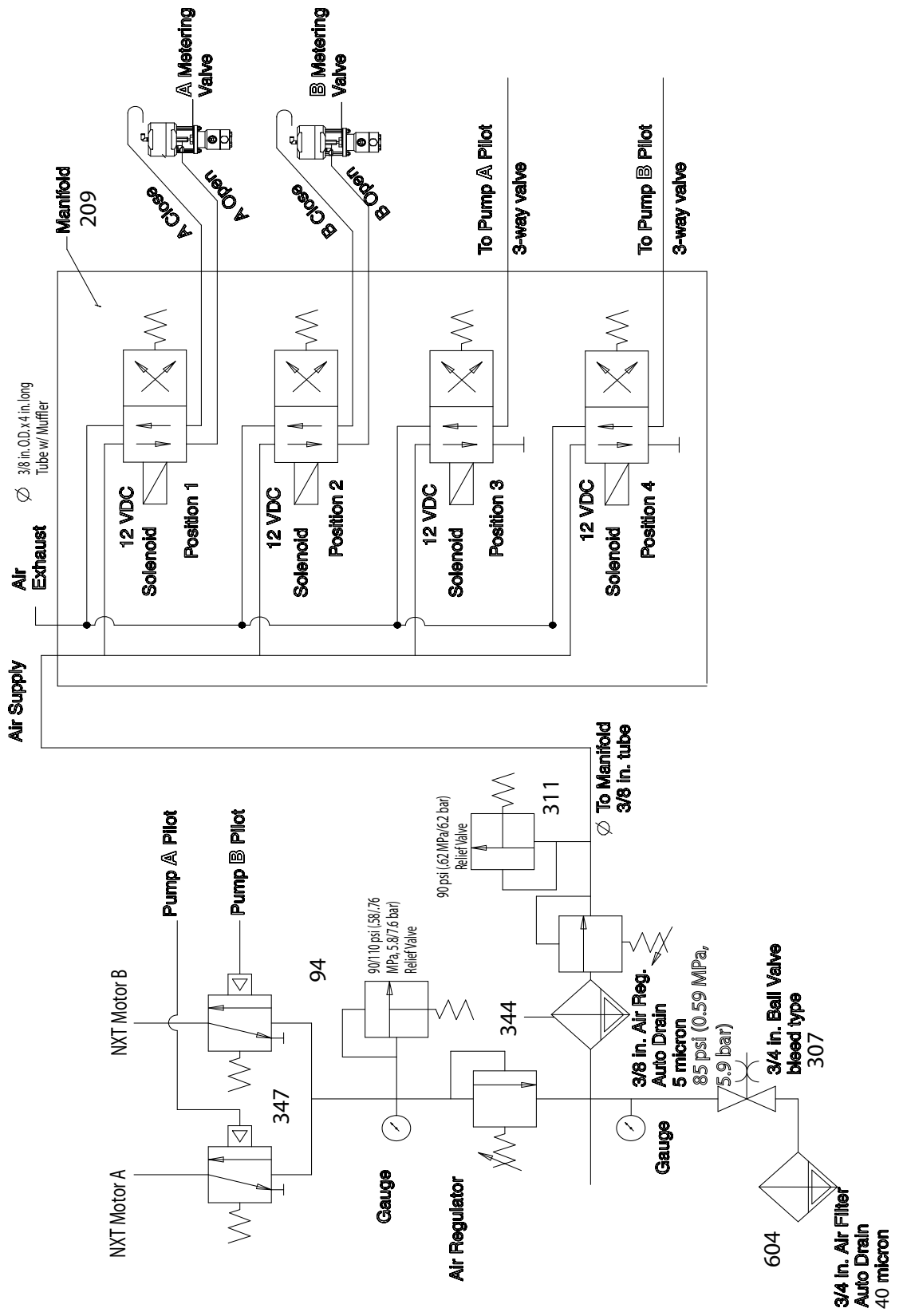

Detailed Electrical Schematic, XM Sprayer with Wall Power (page 1)

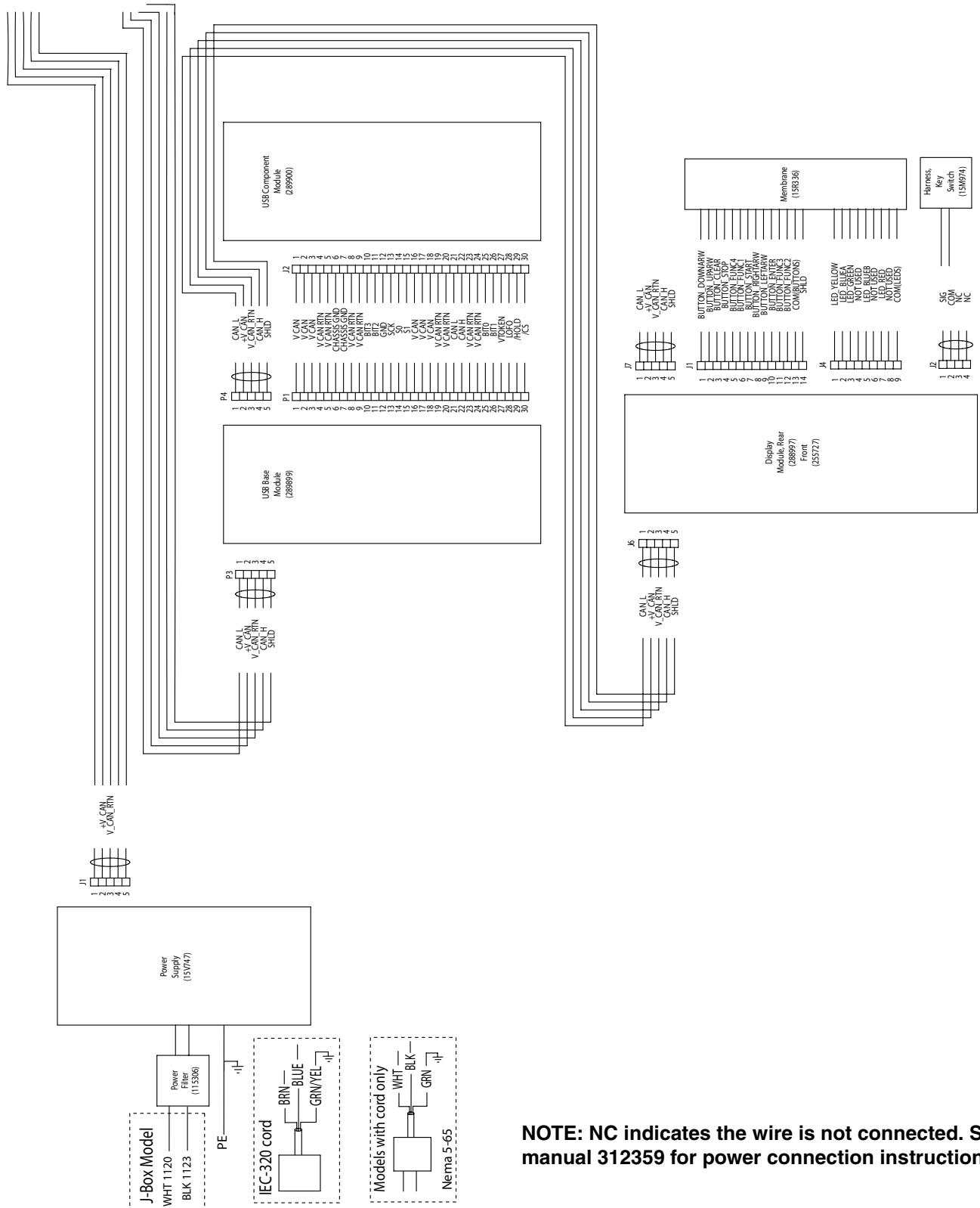

Detailed Electrical Schematic, XM Sprayer with Wall Power (page 2)

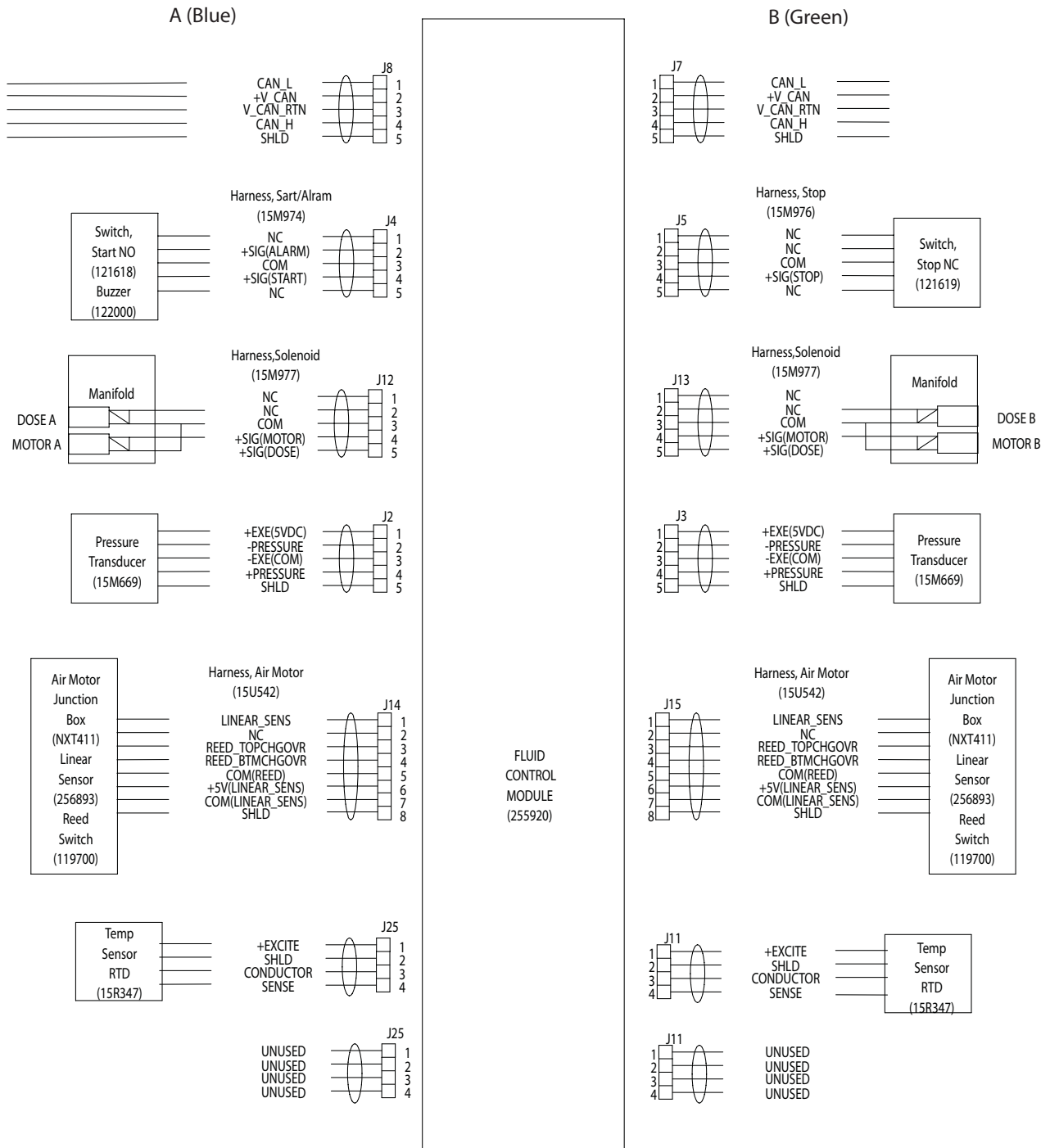

NOTE: NC indicates the wire is not connected.

Junction Box Wiring Schematics

Fluid Heaters

NOTE: See manual 312359 for power connection instructions.

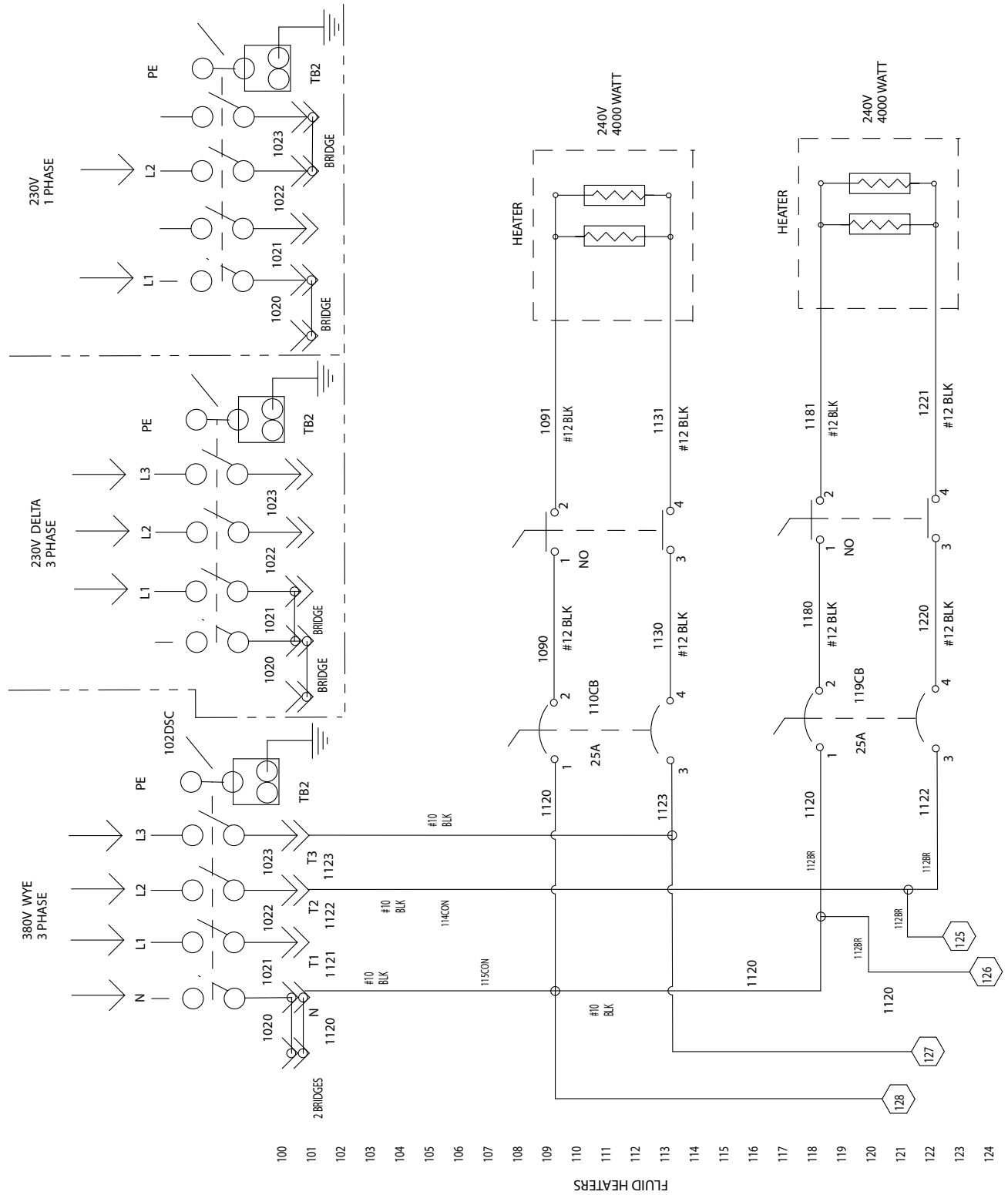

100
101
102
103
104
105
106
107
108
109
110
111
112
113
114
115
116
117
118
119
120
121
122
123
124

FLUID HEATERS

Hopper Heaters

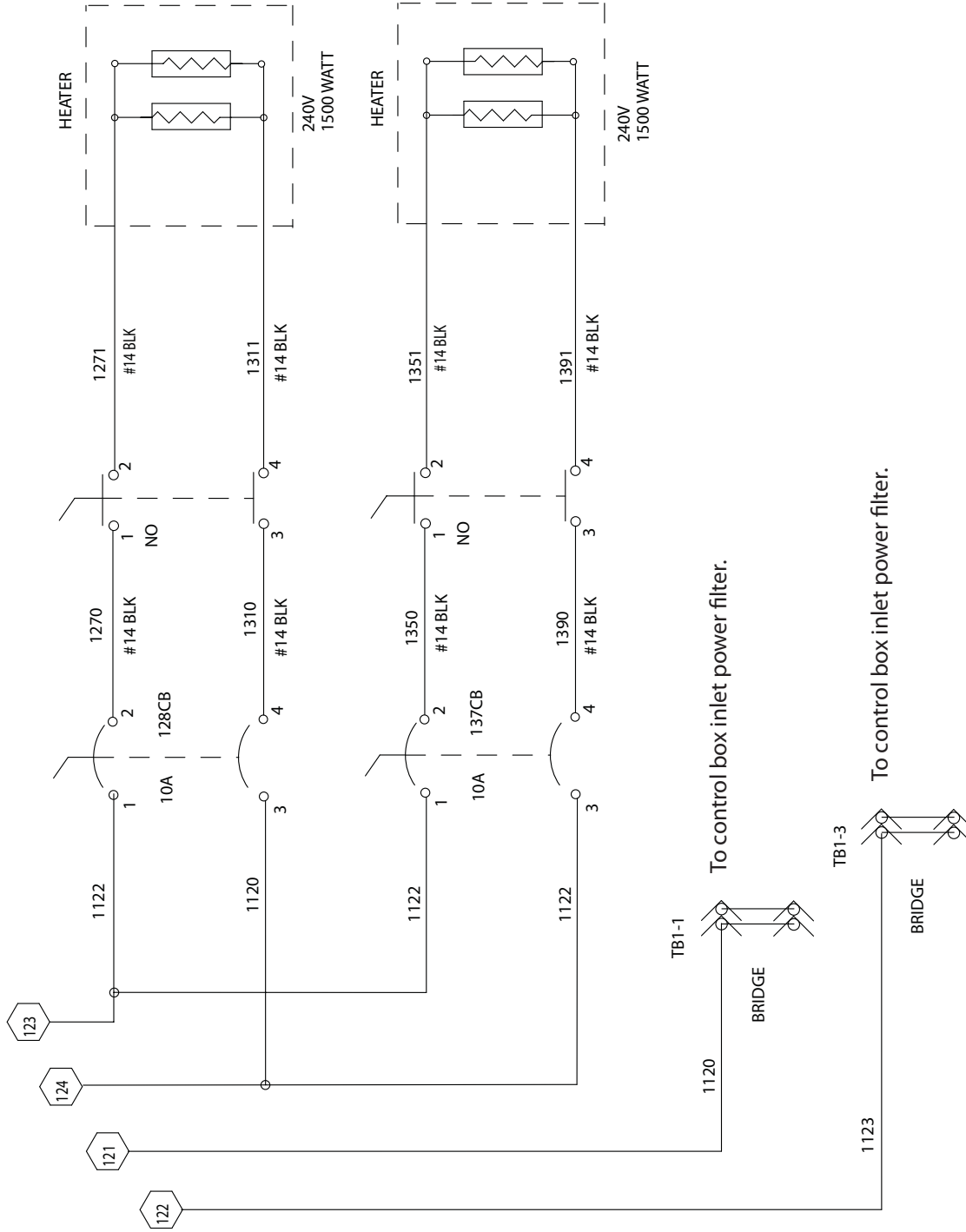

HOPPER HEATERS

Parts

XM Plural-Component Sprayers

 Do not use swivel union end on mixer inlet. Use female pipe thread.

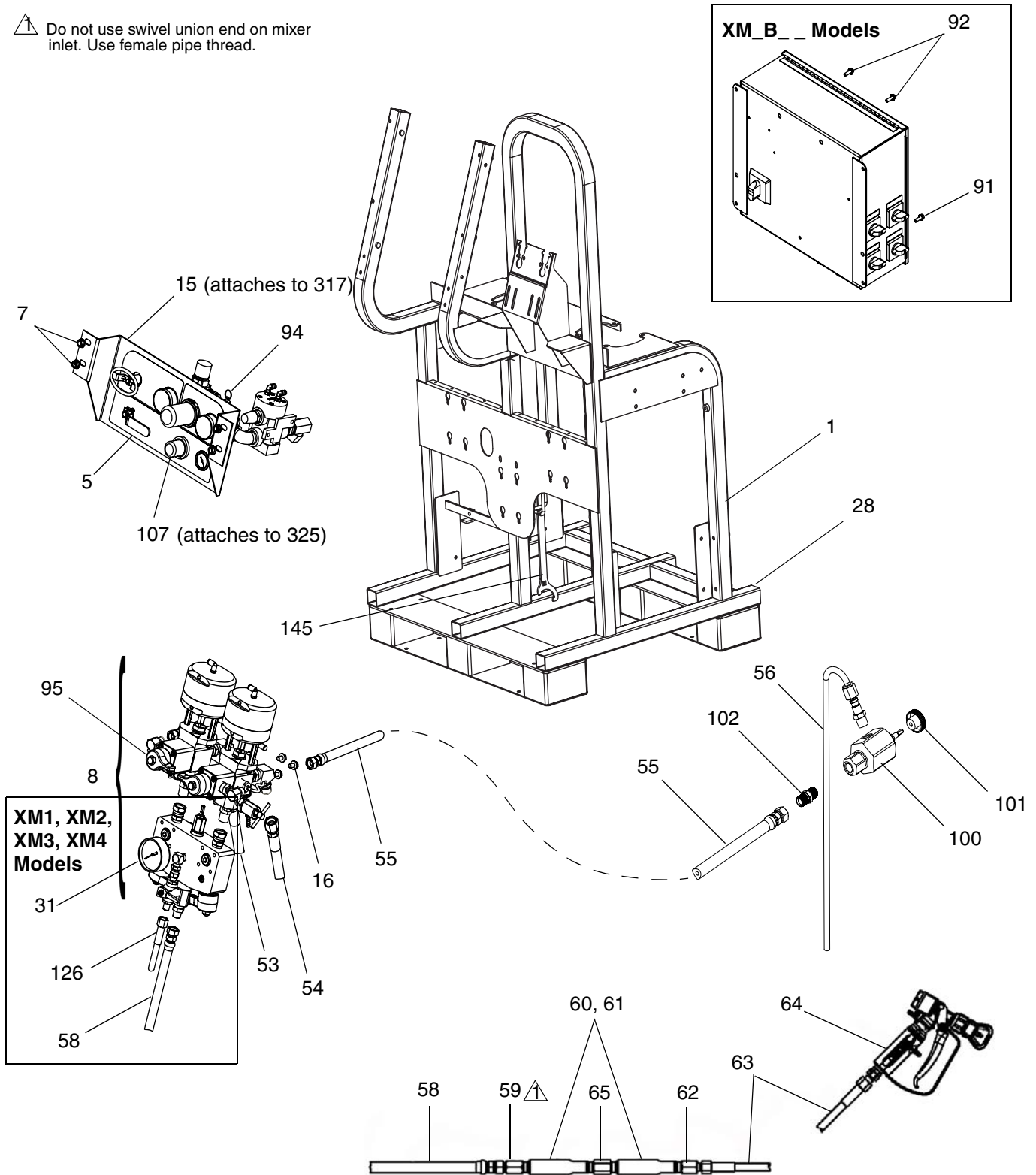

XM Plural-Component Sprayers

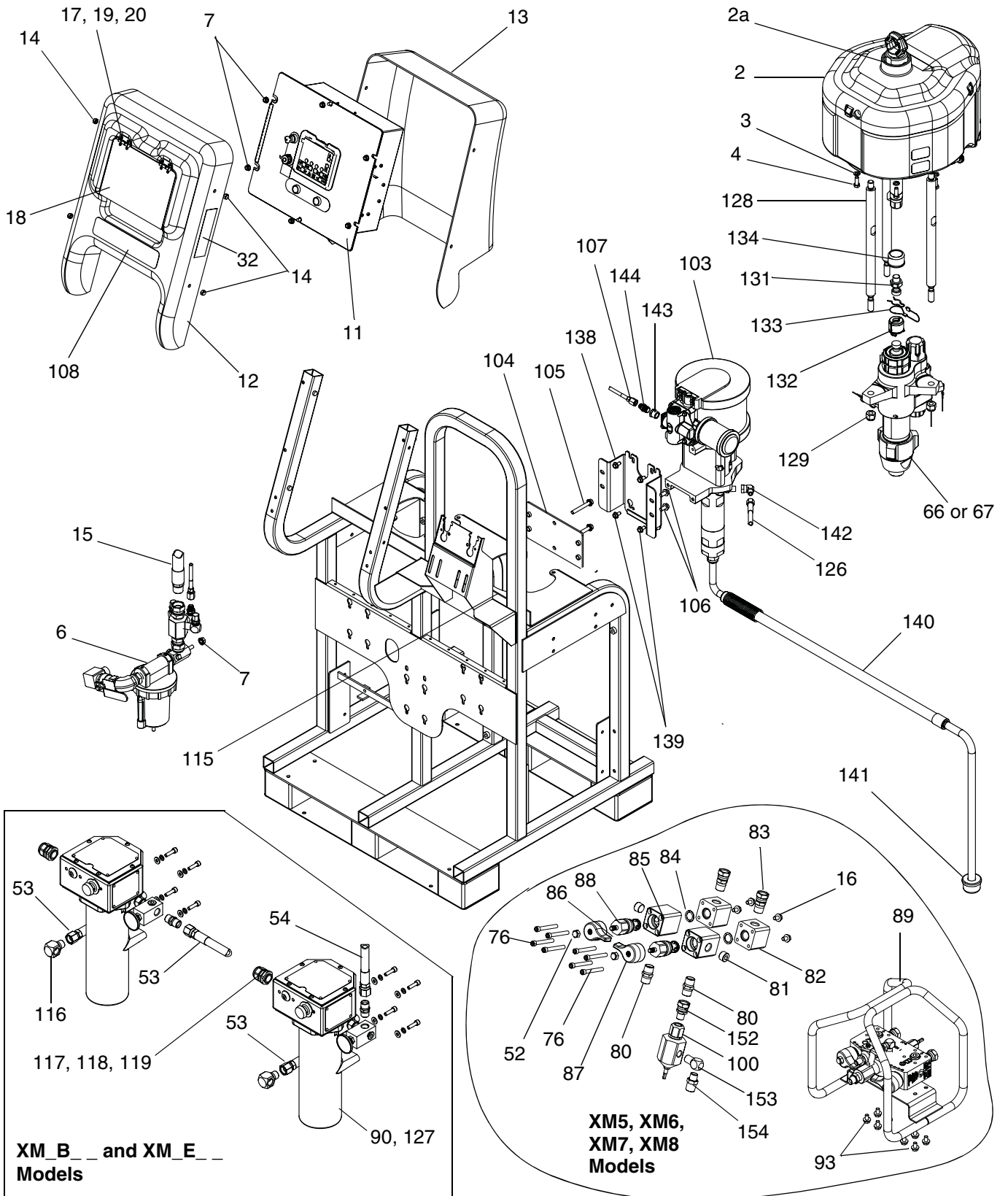

XM Plural-Component Sprayers

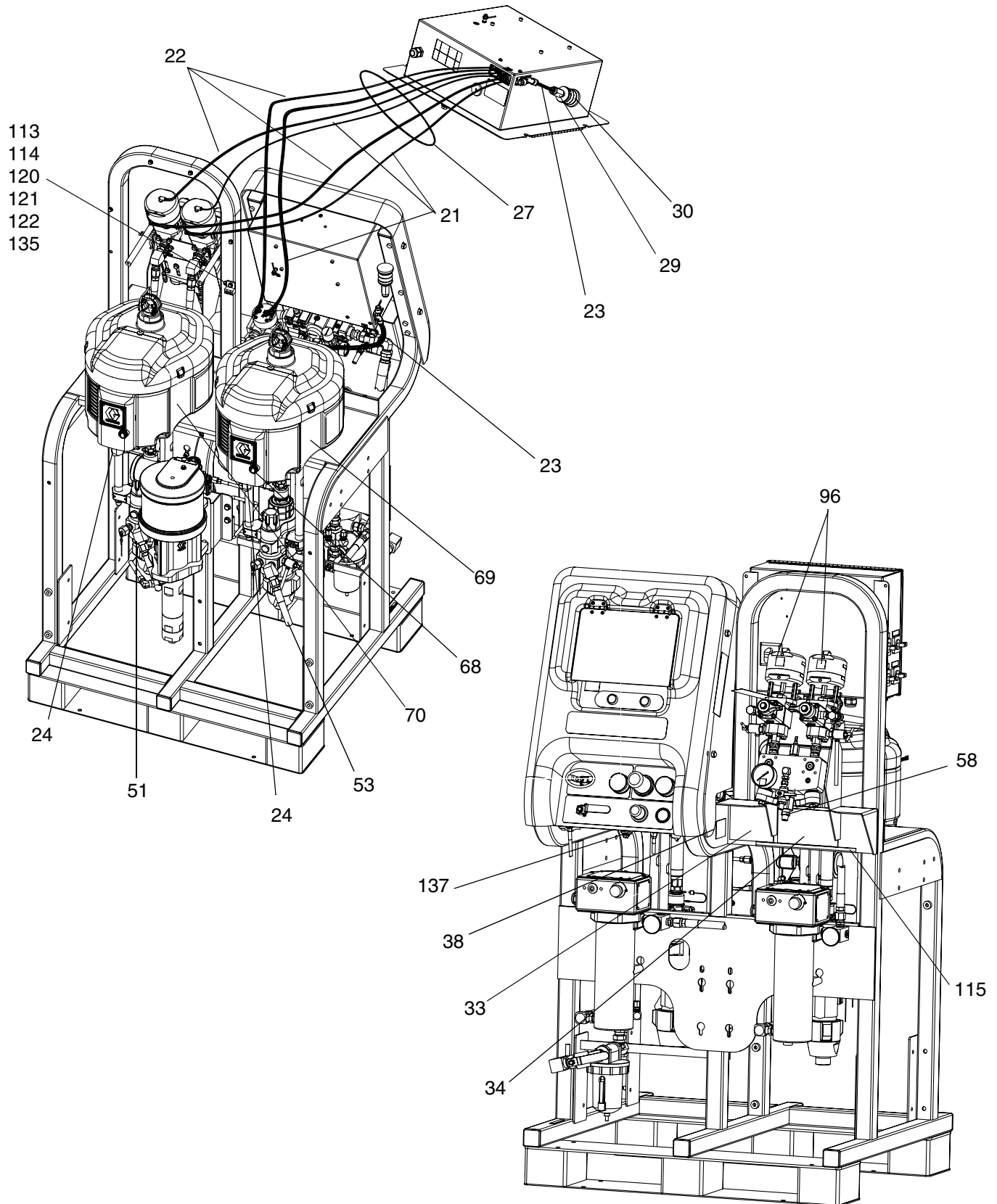

Common Parts

Ref.	Part	Description	Qty.	Ref.	Part	Description	Qty.
				59	15B729	COUPLING; 3/8-18 npsm x 3/8-18 npt	1
1		FRAME	1	60	15E592	HOUSING, mixer	2
2	257055	MOTOR, 6500, de-icing; see manual 311238	2	61*	248927	KIT, mixer, element; pack of 25	1
2a	256893	HOUSING, assy., linear sensor; see manual 311328	2	62	150287	COUPLING; 1/4-18 npsm x 3/8-18 npt	1
2b*	NXT102	CONTROL, assy, de-ice	2	63	H72510	HOSE, coupled; 1/4-18 npsm; 10 ft	1
3	100133	WASHER, lock	8	64	XTR704	GUN	1
4	100101	SCREW, cap, hex hd	8	65	162024	COUPLING; 3/8-18 npt x 3/8-18 npt	1
5	255761	AIR CONTROLS, module, upper; see Air Controls Module (255761) Parts , page 74	1	75*	206995	TSL; 1 qt.	1
6	255762	MANIFOLD, inlet, air distribution; see Air Inlet Manifold (255762) Parts , page 77	1	95	15U655	LABEL, identification	1
7	112958	NUT, hex, flanged	9	96	15U654	LABEL, identification	1
8		FLUID CONTROL, assy; see Fluid Control Assembly Parts , page 76	1	101✓	114593	KNOB	2
11	255771	BOX, control; see Control Box (255771) Parts , page 70	1	103	W30CAS	PUMP, solvent, Merkur; see manual 312794	1
12	256177	SHROUD, front	1	104	256169	PLATE, pump, solvent	1
13	256178	SHROUD, rear	1	105		SCREW, hex hd, flanged	2
14	117623	NUT, cap (3/8-16)	4	106	112395	SCREW, cap, flanged	4
15	240900	HOSE, coupled, 30 in.	3	107	248208	HOSE, coupled; 4 ft	1
16	111801	SCREW, cap, hex hd	10	113	117666	TERMINAL, ground	1
17	121471	HINGE, friction, positioning	2	114	100028	WASHER, lock	1
18	15T568	DOOR, control shroud	1	115	115901	TRIM, edge	2
19	15T567	NUT, backup plate, hinge	4	120		WIRE, ground assy.	1
20	112380	SCREW, mach, pan head	8	121		WIRE, electric; copper	
21	054172	TUBE, nylon, 1/4 OD, black; 10 ft		122	109025	RING, terminal	1
22	054175	TUBE, nylon, 1/4 OD, natural; 7 ft		124▲		LABEL, pressure control	2
23	C12508	TUBE, nylon, round; 1.3 ft		125*✓	162449	NIPPLE, reducing; 1/2 x 1/4 npt	2
24	160327	FITTING, union adapter; 90 deg.	2	128	257150	ROD, tie	6
27	114601	CONDUIT, flexible, non-metallic; 3 ft		129	101712	NUT, lock	6
28	115313	PLUG, tube	8	131	15H392	ROD, adapter	2
29	121688	CONNECTOR; 3/8 npt x 3/8 tube ptc	1	132	244819	COUPLING, assy.	2
30	108636	MUFFLER	1	133	244820	CLIP, hairpin with lanyard	2
31	114434	GAUGE, pressure, fluid, sst	1	134	197340	COVER, coupler	2
32▲	15T468	LABEL, warning	2	135	113796	SCREW, flanged, hex head	1
33▲		LABEL, codes, alerts	1	136*	114958	TIE, strap	10
	15U926	English		137*	054760	TUBE, polyurethane, black; 3.5 ft.	-
	✓15X126	All languages		138	256561	PLATE, mounting, solvent pump	1
34▲	15W598	LABEL, warning	1	139	111799	SCREW, cap, hex head	4
35*	15U656	LABEL, identification	1	140	256421	HOSE, siphon, assy.	1
38	293547	LABEL, identification	1	141	181073	STRAINER, inlet	1
51	15M987	ELBOW; 60 deg.	2	142	116935	SCREW, cap	1
53	H75003	HOSE, coupled; 1/2-14 npsm; 3 ft	3	143	100081	BUSHING, pipe	1
54	H75002	HOSE, coupled; 1/2-14 npsm; 2 ft	1	144	157350	ADAPTER; 3/8 npt x 1/4 npt	1
55✓	H53806	HOSE, coupled; 3/8-18 npsm; 6 ft	2	145	15T258	TOOL, wrench, Xtreme	1
56✓	15T396	TUBE, recirculation	2	146✓	159239	NIPPLE, reducing; 1/2 x 3/8 npt	1
57*	551390	SIGHTGLASS, beaker, graduated	10	147*	16A004	FLASH DRIVE, USB; 4 GB	1
58	H73825	HOSE, coupled; 3/8-18 npsm; 25 ft	1				

▲ Replacement Danger and Warning labels, tags, and cards are available at no cost.

* Not shown.

✓ Not assembled.

Parts Varying by Model

XM1_ _ _ and XM2_ _ _ Models

Ref.	Part	Description	XM-50 Plural-Component Sprayer Models							
			XM1A00	XM1B00	XM1D00	XM1E00	XM2A00	XM2B00	XM2D00	XM2E00
52	117623	NUT, cap								
66	L250C4	LOWER, A side; see manual 311762	1	1	1	1				
	L250C3	LOWER, A side (without filter); see manual 311762					1	1	1	1
67	L220C4	LOWER, B side; see manual 311762	1	1	1	1				
	L220C3	LOWER, B side (without filter); see manual 311762					1	1	1	1
69	15H652	LABEL, motor, A side	1	1	1	1	1	1	1	1
70	15H654	LABEL, motor, B side	1	1	1	1	1	1	1	1
76	121295	SCREW, cap, socket head								
77		LABEL, system	1	1			1	1		
					1	1			1	1
80	158491	NIPPLE; 1/2 npt	2	2	2	2	2	2	2	2
81	100361	PLUG, pipe								
82	15R529	BLOCK, fluid distribution								
83	156684	UNION, adapter								
84	121139	O-RING; PTFE								
85	15J594	HOUSING, check valve								
86	15J916	HANDLE, blue								
87	15R380	HANDLE, green								
88	255747	CARTRIDGE, valve								
89	24A034	CARRIAGE, remote mix manifold								
90	245869	HEATER, fluid		2				2		
	245863					2				2
91	256540	BOX, junction		1				1		
92	113796	SCREW, flanged, hex head	1	5	1	1	1	5	1	1
93	111801	SCREW, cap, hex head								
94	113498	VALVE, relief; 110 psi (0.76 MPa, 7.6 bar)	1	1	1	1	1	1	1	1
100✓	222200	VALVE, restrictor	2	2	2	2	2	2	2	2
102✓	156849	PIPE, nipple; 3/8 npt	2	2	2	2	2	2	2	2
108		LABEL, XM50	1	1	1	1	1	1	1	1
		LABEL, XM70								
112		CABLE, CAN, IS, display to USB; female B/female B	1	1			1	1		
116†	158683	ELBOW, 90 deg.		2		2		2		2
117	15T967	CABLE, heater		2				2		
118	116171	BUSHING, strain relief		2				2		
119	122032	NUT, wire		4				4		
126	H42506	HOSE, coupled, 4500 psi	1	1	1	1	1	1	1	1
127	100527	WASHER		8		8		8		8

XM1___ and XM2___ Models (continued)

Ref.	Part	Description	XM-50 Plural-Component Sprayer Models							
			XM1A00	XM1B00	XM1D00	XM1E00	XM2A00	XM2B00	XM2D00	XM2E00
128*	224458	STRAINER, pump; 30 mesh (qty. of 2)	1	1	1	1				
152	162505	UNION, swivel; 3/8 male x 1/2 female npt								
153	155699	ELBOW, street; 3/8-18 npt								
154	159239	NIPPLE, pipe; 1/2 x 3/8 npt								
155	164672	ADAPTER								

† *Must purchase when installing fluid heaters on a non-heated sprayer.*

* *Not shown.*

✓ *Not assembled.*

Parts Varying by Model (continued)

XM3_ _ _ and XM4_ _ _ Models

Ref.	Part	Description	XM Plural-Component Sprayer Models							
			XM3A00	XM3B00	XM3D00	XM3E00	XM4A00	XM4B00	XM4D00	XM4E00
52	117623	NUT, cap								
66	L180C4	LOWER, A side; see manual 311762	1	1	1	1				
	L180C3	LOWER, A side (without filter); see manual 311762					1	1	1	1
67	L145C4	LOWER, B side; see manual 311762	1	1	1	1				
	L145C3	LOWER, B side (without filter); see manual 311762					1	1	1	1
69	15H107	LABEL, motor, A side	1	1	1	1	1	1	1	1
70	15J692	LABEL, motor, B side	1	1	1	1	1	1	1	1
76	121295	SCREW, cap, socket head								
77		LABEL, system	1	1			1	1		
					1	1			1	1
80	158491	NIPPLE; 1/2 npt	2	2	2	2	2	2	2	2
81	100361	PLUG, pipe								
82	15R529	BLOCK, fluid distribution								
83	156684	UNION, adapter								
84	121139	O-RING; PTFE								
85	15J594	HOUSING, check valve								
86	15J916	HANDLE, blue								
87	15R380	HANDLE, green								
88	255747	CARTRIDGE, valve								
89	24A034	CARRIAGE, remote mix manifold								
90	245869	HEATER, fluid		2				2		
	245863					2				2
91	256540	BOX, junction		1				1		
92	113796	SCREW, flanged, hex head	1	5	1	1	1	5	1	1
93	111801	SCREW, cap, hex head								
94	116643	VALVE, relief; 90 psi (0.63 MPa, 6.3 bar)	1	1	1	1	1	1	1	1
100✓	222200	VALVE, restrictor	2	2	2	2	2	2	2	2
102✓	156849	PIPE, nipple; 3/8 npt	2	2	2	2	2	2	2	2
108		LABEL, XM50								
		LABEL, XM70	1	1	1	1	1	1	1	1
112		CABLE, CAN, IS, display to USB; female B/female B	1	1			1	1		
116†	158683	ELBOW, 90 deg.		2		2		2		2
117	15T967	CABLE, heater		2				2		
118	116171	BUSHING, strain relief		2				2		
119	122032	NUT, wire		4				4		
126	H42506	HOSE, coupled, 4500 psi	1	1	1	1	1	1	1	1
127	100527	WASHER		8		8		8		8

XM3___ and XM4___ Models (continued)

Ref.	Part	Description	XM Plural-Component Sprayer Models							
			XM3A00	XM3B00	XM3D00	XM3E00	XM4A00	XM4B00	XM4D00	XM4E00
128*	224458	STRAINER, pump; 30 mesh (qty. of 2)	1	1	1	1				
152	162505	UNION, swivel; 3/8 male x 1/2 female npt								
153	155699	ELBOW, street; 3/8-18 npt								
154	159239	NIPPLE, pipe; 1/2 x 3/8 npt								
155	164672	ADAPTER								

† *Must purchase when installing fluid heaters on a non-heated sprayer.*

* *Not shown.*

✓ *Not assembled.*

Parts Varying by Model (continued)

XM5_ _ _ and XM6_ _ _ Models

Ref.	Part	Description	XM Plural-Component Sprayer Models							
			XM5A00	XM5B00	XM5D00	XM5E00	XM6A00	XM6B00	XM6D00	XM6E00
52	117623	NUT, cap	2	2	2	2	2	2	2	2
66	L250C4	LOWER, A side; see manual 311762	1	1	1	1				
	L250C3						1	1	1	1
67	L220C4	LOWER, B side; see manual 311762	1	1	1	1				
	L220C3						1	1	1	1
69	15H652	LABEL, motor, A side	1	1	1	1	1	1	1	1
70	15H654	LABEL, motor, B side	1	1	1	1	1	1	1	1
76	121295	SCREW, cap, socket head	8	8	8	8	8	8	8	8
77		LABEL, system	1	1			1	1		
					1	1			1	1
80	158491	NIPPLE; 1/2 npt	4	4	4	4	4	4	4	4
81	100361	PLUG, pipe	2	2	2	2	2	2	2	2
82	15R529	BLOCK, fluid distribution	2	2	2	2	2	2	2	2
83	156684	UNION, adapter	2	2	2	2	2	2	2	2
84	121139	O-RING; PTFE	2	2	2	2	2	2	2	2
85	15J594	HOUSING, check valve	2	2	2	2	2	2	2	2
86	15J916	HANDLE, blue	1	1	1	1	1	1	1	1
87	15R380	HANDLE, green	1	1	1	1	1	1	1	1
88	255747	CARTRIDGE, valve	2	2	2	2	2	2	2	2
89	24A034	CARRIAGE, remote mix manifold	1	1	1	1	1	1	1	1
90	245869	HEATER, fluid		2				2		
	245863					2				2
91	256540	BOX, junction		1				1		
92	113796	SCREW, flanged, hex head	1	5	1	1	1	5	1	1
93	111801	SCREW, cap, hex head	8	8	8	8	8	8	8	8
94	113498	VALVE, relief; 110 psi (0.76 MPa, 7.6 bar)	1	1	1	1	1	1	1	1
100✓	222200	VALVE, restrictor	3	3	3	3	3	3	3	3
102❖	156849	PIPE, nipple; 3/8 npt	3	3	3	3	3	3	3	3
108		LABEL, XM50	1	1	1	1	1	1	1	1
		LABEL, XM70								
112		CABLE, CAN, IS, display to USB; female B/female B	1	1			1	1		
116†	158683	ELBOW, 90 deg.		2		2		2		2
117	15T967	CABLE, heater		2				2		
118	116171	BUSHING, strain relief		2				2		
119	122032	NUT, wire		4				4		
126	H42506	HOSE, coupled, 4500 psi								
127	100527	WASHER		8		8		8		8

XM5___ and XM6___ Models

Ref.	Part	Description	XM Plural-Component Sprayer Models							
			XM5A00	XM5B00	XM5D00	XM5E00	XM6A00	XM6B00	XM6D00	XM6E00
128*	224458	STRAINER, pump; 30 mesh (qty. of 2)	1	1	1	1				
152	162505	UNION, swivel; 3/8 male x 1/2 female npt	1	1	1	1	1	1	1	1
153	155699	ELBOW, street; 3/8-18 npt	1	1	1	1	1	1	1	1
154	159239	NIPPLE, pipe; 1/2 x 3/8 npt	1	1	1	1	1	1	1	1
155	164672	ADAPTER	1	1	1	1	1	1	1	1

† *Must purchase when installing fluid heaters on a non-heated sprayer.*

* *Not shown.*

✓ *Not assembled.*

❖ *Assemble remote restrictor valve.*

Parts Varying by Model (continued)

XM7_ _ _ and XM8_ _ _ Models

Ref.	Part	Description	XM Plural-Component Sprayer Models							
			XM7A00	XM7B00	XM7D00	XM7E00	XM8A00	XM8B00	XM8D00	XM8E00
52	117623	NUT, cap	2	2	2	2	2	2	2	2
66	L180C4	LOWER, A side; see manual 311762	1	1	1	1				
	L180C3						1	1	1	1
67	L145C4	LOWER, B side; see manual 311762	1	1	1	1				
	L145C3						1	1	1	1
69	15H107	LABEL, motor, A side	1	1	1	1	1	1	1	1
70	15J692	LABEL, motor, B side	1	1	1	1	1	1	1	1
76	121295	SCREW, cap, socket head	8	8	8	8	8	8	8	8
77		LABEL, system	1	1			1	1		
					1	1			1	1
80	158491	NIPPLE; 1/2 npt	4	4	4	4	4	4	4	4
81	100361	PLUG, pipe	2	2	2	2	2	2	2	2
82	15R529	BLOCK, fluid distribution	2	2	2	2	2	2	2	2
83	156684	UNION, adapter	2	2	2	2	2	2	2	2
84	121139	O-RING; PTFE	2	2	2	2	2	2	2	2
85	15J594	HOUSING, check valve	2	2	2	2	2	2	2	2
86	15J916	HANDLE, blue	1	1	1	1	1	1	1	1
87	15R380	HANDLE, green	1	1	1	1	1	1	1	1
88	255747	CARTRIDGE, valve	2	2	2	2	2	2	2	2
89	24A034	CARRIAGE, remote mix manifold	1	1	1	1	1	1	1	1
90	245869	HEATER, fluid		2				2		
	245863					2				2
91	256540	BOX, junction		1				1		
92	113796	SCREW, flanged, hex head	1	5	1	1	1	5	1	1
93	111801	SCREW, cap, hex head	8	8	8	8	8	8	8	8
94	116643	VALVE, relief; 90 psi (0.63 MPa, 6.3 bar)	1	1	1	1	1	1	1	1
100✓	222200	VALVE, restrictor	3	3	3	3	3	3	3	3
102❖	156849	PIPE, nipple; 3/8 npt	3	3	3	3	3	3	3	3
108		LABEL, XM50								
		LABEL, XM70	1	1	1	1	1	1	1	1
112		CABLE, CAN, IS, display to USB; female B/female B	1	1			1	1		
116†	158683	ELBOW, 90 deg.		2		2		2		2
117	15T967	CABLE, heater		2				2		
118	116171	BUSHING, strain relief		2				2		
119	122032	NUT, wire		4				4		
126	H42506	HOSE, coupled, 4500 psi								
127	100527	WASHER		8		8		8		8

XM7___ and XM8___ Models

Ref.	Part	Description	XM Plural-Component Sprayer Models							
			XM7A00	XM7B00	XM7D00	XM7E00	XM8A00	XM8B00	XM8D00	XM8E00
128*	224458	STRAINER, pump; 30 mesh (qty. of 2)	1	1	1	1				
152	162505	UNION, swivel; 3/8 male x 1/2 female npt	1	1	1	1	1	1	1	1
153	155699	ELBOW, street; 3/8-18 npt	1	1	1	1	1	1	1	1
154	159239	NIPPLE, pipe; 1/2 x 3/8 npt	1	1	1	1	1	1	1	1
155	164672	ADAPTER	1	1	1	1	1	1	1	1

† *Must purchase when installing fluid heaters on a non-heated sprayer.*

* *Not shown.*

✓ *Not assembled.*

❖ *Assemble remote restrictor valve.*

Control Box (255771) Parts

Air Power and Electric Power Versions

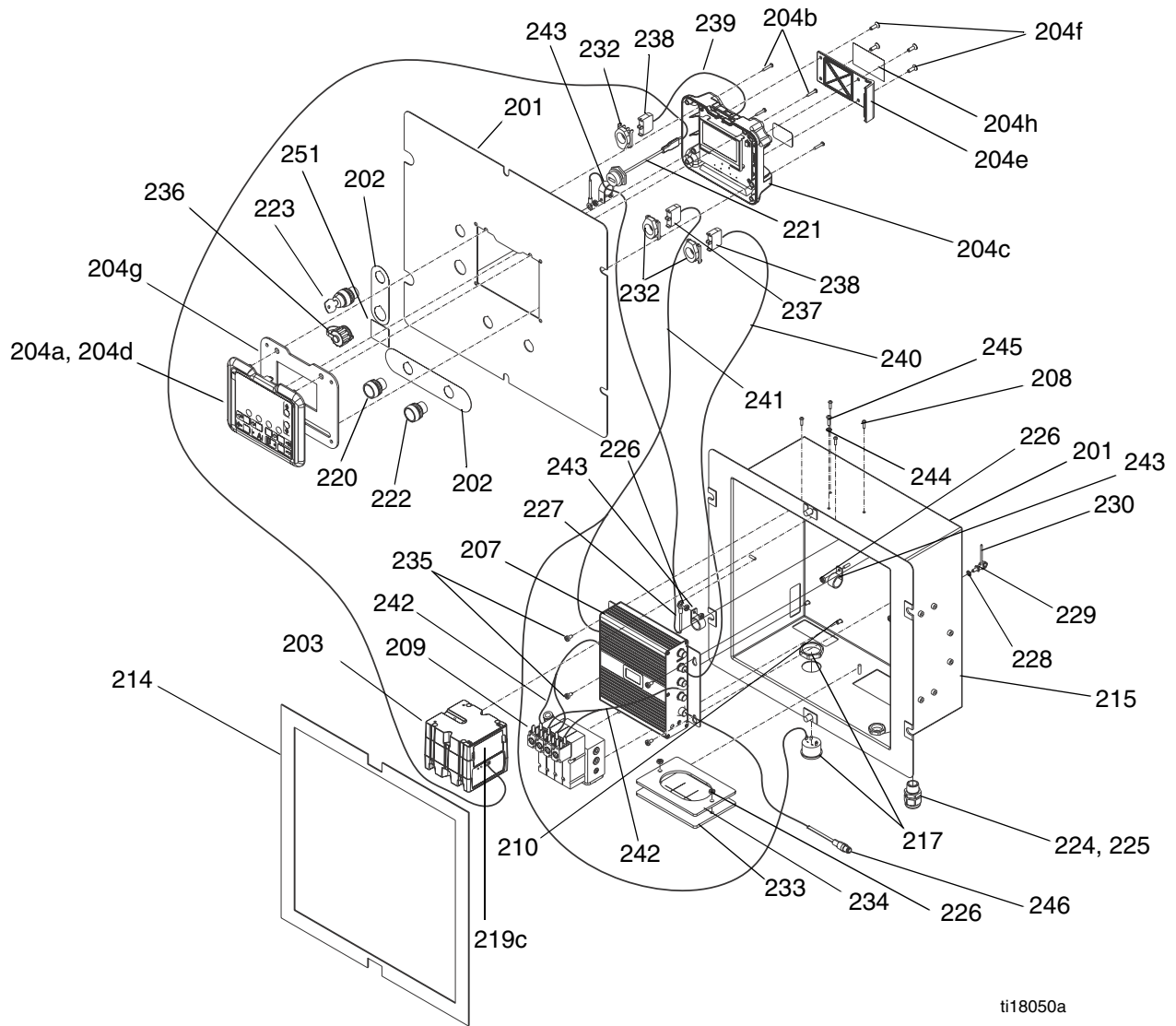

Ref.	Part	Description	Qty.	Ref.	Part	Description	Qty.
201		BOX, control	1	205†	262642	Kit, replacement, display; includes 204 and 206	1
202		LABEL, control display	1	206	16A265	TOKEN, software	1
203†	262641	KIT, replacement, USB; includes 219 and 206	1	207†	262643	KIT, replacement, FCM; includes 218 and 206	1
204●	257484	MODULE, display, kit		208		SCREW, pan head	4
204a	15M483	SHIELD, membrane, display (qty. 10)	1	209	256555	MODULE, solenoid, IS version	1
204b		SCREW, pan head; #6 x 7/8 in.	4	209a	121636	VALVE, solenoid, din connector	4
●204c	288997	CASE, rear, display module, IS version	1	209b	15A789	GASKET, solenoid, outlet	1
204d	255727	CASE, front, data module	1	209c	15A799	GASKET, solenoid, inlet/exhaust	1
204e	277463	COVER, access, low level display	1	210	106084	SCREW, machine, pan head	2
204f	113768	SCREW, socket, flat head	4	214	15R379	GASKET, box, control	1
204g	15R458	GASKET, control, front panel	1	215		LABEL	1
▲204h	15W958	LABEL, warning, battery	1	216*	15B056	LABEL, air motor/dosing valve	1
				217	122000	ALARM, panel mount	1

Ref.	Part	Description	Qty.
218●	255920	MODULE, fluid control	1
219●	257088	MODULE, USB, assy.	
219a	289899	BASE	1
●219b	289900	MODULE, USB	1
219c	277674	DOOR, module	1
220	121618	SWITCH, start, push button, green	1
221	15R324	HARNESS, USB, plug/bulkhead; 32 in.	1
222	121619	SWITCH, stop, push button, red	1
223	121617	SWITCH, 2 position, key, controls	1
223a*	123412	KEY, replacement (pair)	
224	117745	BUSHING, strain relief	1
225	117625	NUT, locking	1
226	113505	NUT, keps, hex head	6
227	15B090	WIRE, grounding, door	1
228	558685	WASHER, lock, external	1
229	15R343	CLAMP, ground, electrical	1
230	065213	WIRE, copper, elect	3
231*	172953	LABEL, designation	2
232	120493	LATCH, mounting	3
233	15H189	BOOT, wire feed through	1
234	15G816	COVER, plate, wire	1
235	110637	SCREW, machine, pan head	4
236	15R325	COVER, dust, bulkhead receptacle	1
237	120494	BLOCK, switch, n.o.	2
238	120495	BLOCK, switch, n.c.	1
239	15M974	HARNESS, key switch	1
240	15M975	HARNESS, start/alarm	1
241	15M976	HARNESS, stop	1
242	15M977	HARNESS, solenoid	2
243	121988	RETAINER, routing, wire harness	4
244	195875	SCREW, machine, pan head	1
245	102063	WASHER, lock	1
246	15U542	CABLE, motor	2
251▲		LABEL, warning, USB	1
	15X214	English	
	15X393	All languages	
252*	122829	CONDUIT; 0.75 ft.	-

▲ Replacement Danger and Warning labels, tags, and cards are available at no cost.

* Not shown.

● Base electronic components do not have XM-specific software installed. Therefore, use software upgrade token (206) to install software before use.

† Includes software token (206) and instruction sheet.

Control Box Power Supply Options

Alternator Assembly

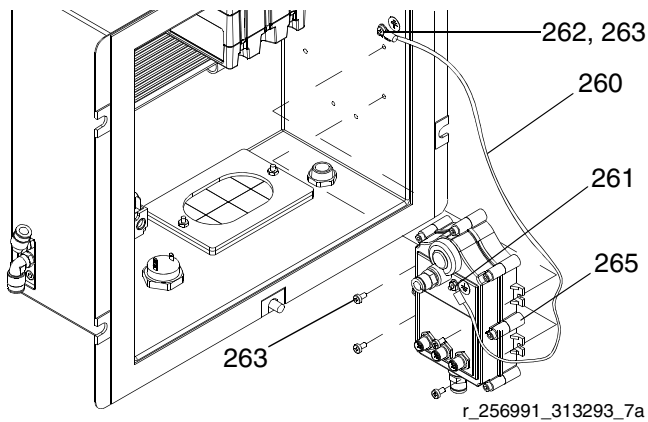

Ref.	Part	Description	Qty.
260	15B090	WIRE, grounding, door	1
261	100284	NUT, hex	1
262	102063	WASHER, lock; carbon steel	1
263	110637	SCREW, machine pan head	5
264*	C12508	TUBING, round; nylon; 5.0 ft	
265	255728	ALTERNATOR, module; see page 78	1
266	15V778	CABLE, CAN, IS, female B/female B; 20 in.	1
267	15V782	CABLE, CAN, IS, male B/female B; 20 in.	1
268	15V783	CABLE, CAN, IS, female A/male B; 39 in.	1

Alternator Assembly Cable Connections

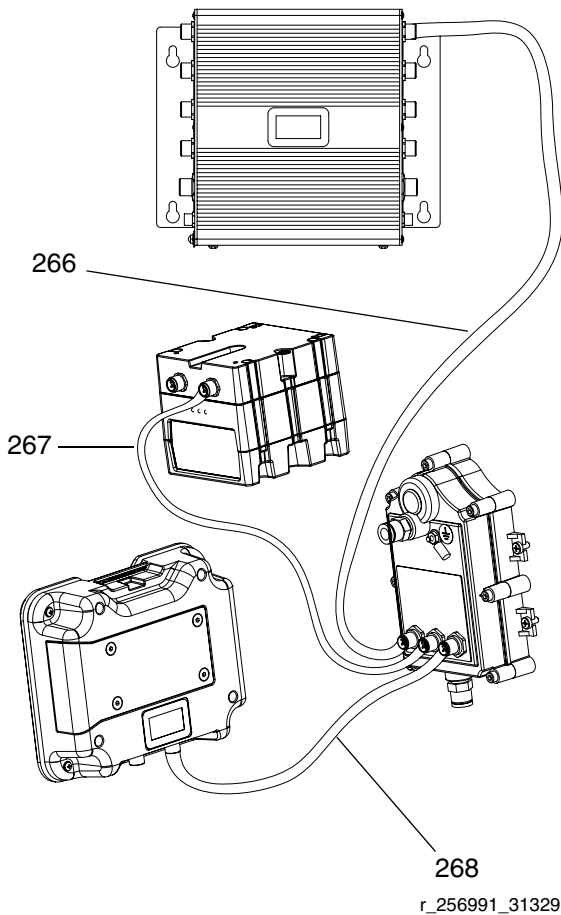

Air Regulator Assembly

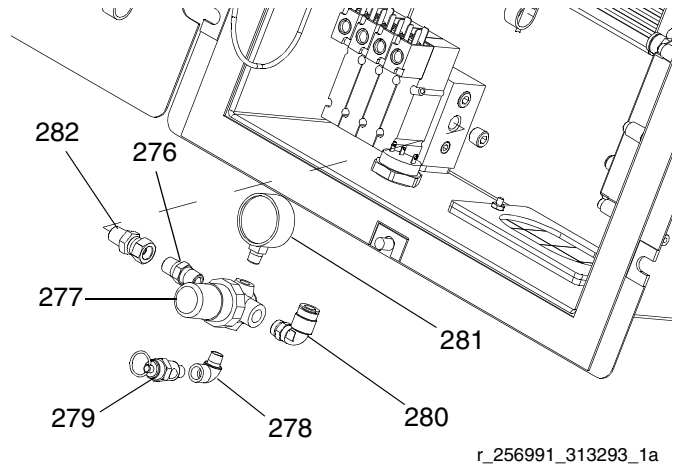

Ref.	Part	Description	Qty.
276	156971	NIPPLE, short; 2 x 1/4-18 npt	1
277	115243	REGULATOR, air; 1/4 npt	1
278	112307	ELBOW, union; 90 deg.; 1/8 npt(f) x 1/8 npt(m); carbon steel	1
279	15W017	VALVE, safety, regulator	1
280	115841	ELBOW, swivel, male; 1/4 npt	1
281	104655	GAUGE, air pressure	1
282	156823	SWIVEL, union; 2 x 1/4-18 npt	1

Wall Power Supply Assembly

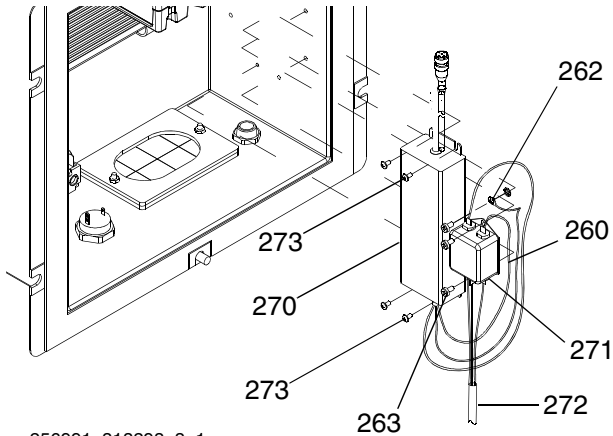

r_256991_313293_3a1

Ref.	Part	Description	Qty.
262	102063	WASHER, lock; carbon steel	1
263	110637	SCREW, machine pan head	3
266	15V778	CABLE, CAN, IS, female B/female B; 20 in.	1
270	15V747	POWER SUPPLY; 24V, 2.5A, 60W	1
271	115306	FILTER, power supply	1
272*		CABLE, power, control box	1
272a*	15X407	CABLE, power, US plug	1
272b*	15Y685	CORD; 240V, 10A, IEC320	1
	195551	RETAINER, adapter, cord	1
	242001	CORD, set, adapter, Europe	1
	242005	CORD, set, adapter, Australia	1
273	100035	SCREW, machine pan head	4
274	15V779	CABLE, CAN, IS, female B/female B; 39.4 in.	1

* Used on XM_A_ _ models only.

* Not shown.

Wall Power Supply Assembly Cable Connections

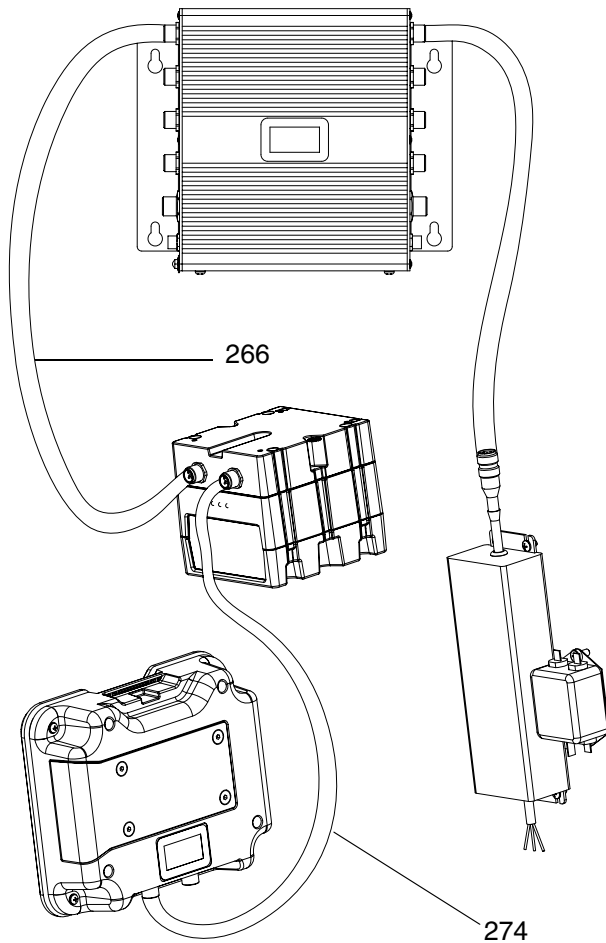

r_256991_313293_10

Air Controls Module (255761) Parts

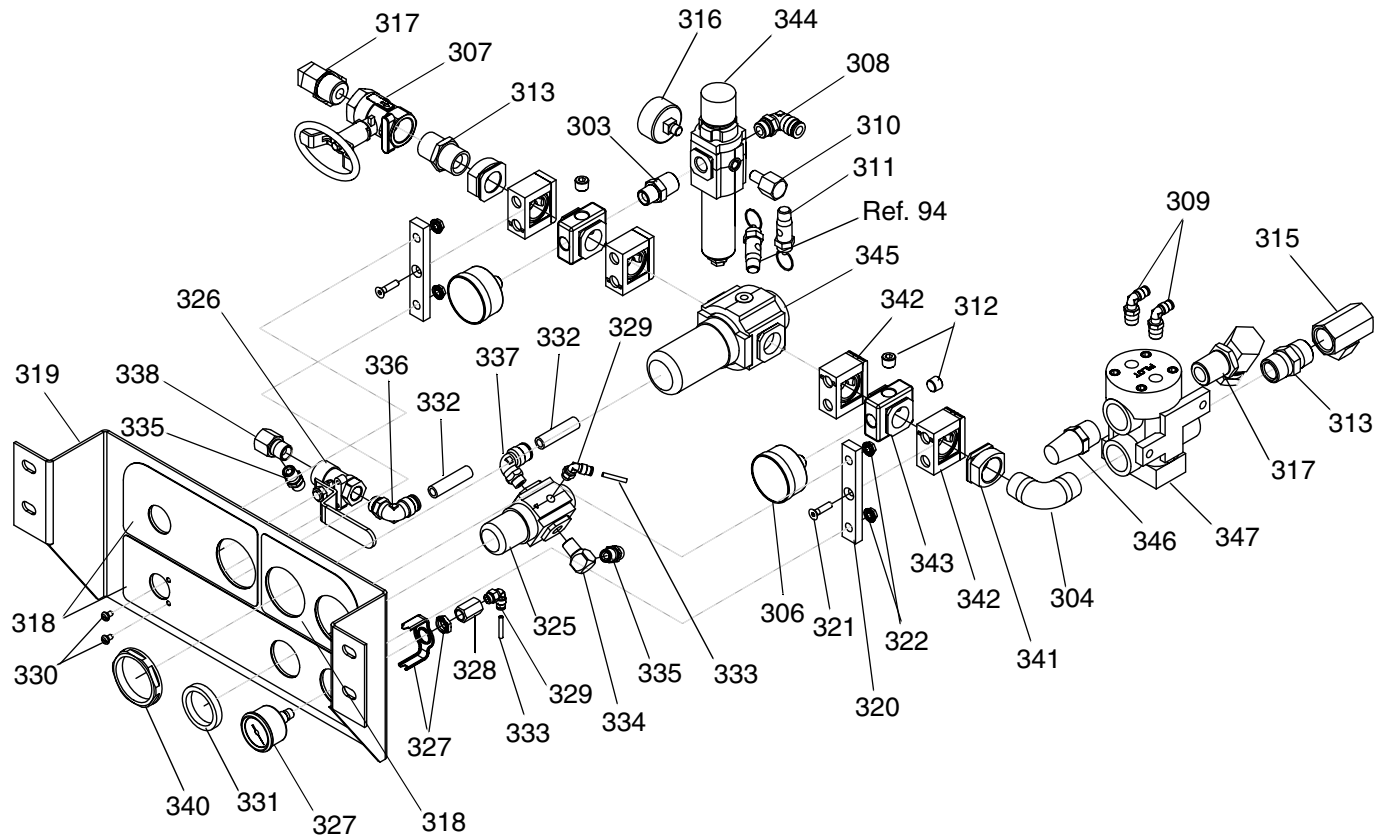

Ref.	Part	Description	Qty.	Ref.	Part	Description	Qty.
303	157350	NIPPLE, pipe; 1/2 x 3/8 npt	1	332	054760	TUBE, polyurethane, round, black; 1.25 in.	-
304	108307	ELBOW, pipe, male	1	333		TUBE, polyurethane, round; 0.6 ft.	-
306	101689	GAUGE, press, air	2	334	100840	ELBOW, street	1
307	117346	VALVE, ball, vented	1	335	162453	FITTING; 1/4 npsm x 1/4 npt	2
308	114316	ELBOW, male, swivel	1	336	114114	ELBOW, male, swivel	1
309*	114109	ELBOW, male, swivel; 1/4 OD tube	2	337	114128	ELBOW, male, swivel	1
310	158962	ELBOW, street; 1/4(f) x 1/8(m)	1	338	164259	ELBOW, street	1
311	116643	VALVE, safety, relief, air	1	340★	122336	NUT, panel, regulator	1
312	100721	PLUG, pipe	3	341★	113440	ADAPTER	2
313	119992	PIPE, nipple; 3/4 x 3/4 npt	2	342★	113431	CLAMP, quick	4
315	156589	ADAPTER, union; 90 deg.	1	343★	113442	BLOCK, porting	2
316	113911	GAUGE, pressure, air	1	344★	15R488	REGULATOR	1
317	160327	ADAPTER, union; 90 deg.	2	344a	123454	FILTER, element; 5 micron	1
318	15T119	LABEL, control	1	345★	15R487	REGULATOR	1
319		BRACKET, air controls	1	346★	15R486	MUFFLER	1
320	15R437	BRACKET, adapter, air controls	2	347★	15R485	VALVE, dual pilot	1
321	121432	SCREW, machine, hex flat head	2				
322	115942	NUT, hex, flange head	4				
325	116513	REGULATOR, air	1				
326	121457	VALVE, ball, air, panel mounted	1				
327	121424	GAUGE, pressure, panel mount, 1.5 in.	1				
328	100451	COUPLING	1				
329	114151	ELBOW, male, swivel	2				
330	100264	SCREW, machine, pan head	2				
331	116514	NUT, regulator	1				

★ Parts included in Air Controls Kit 255772 (purchase separately).

* Early models used 114469 for 5/32 tube.

Junction Box (256540) Parts

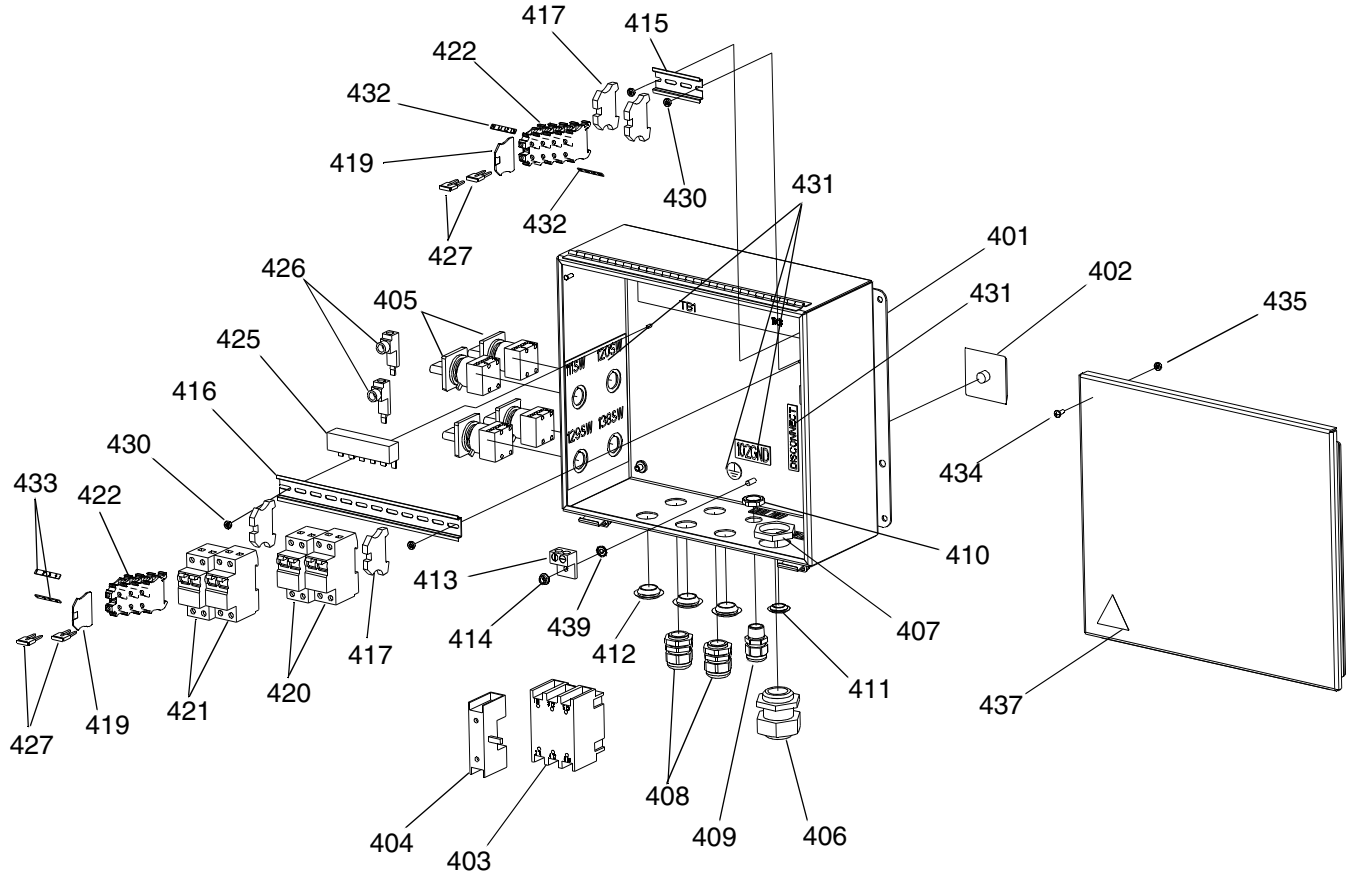

r_312359_313289_38

Ref.	Part	Description	Qty.	Ref.	Part	Description	Qty.
401		ENCLOSURE, electrical	1	428*	15U954	HARNESSESS, junction box	1
402	117545	KNOB, operator disconnect	1	430	113505	NUT, keps, hex head	4
403	117564	SWITCH, disconnect; 100A	1	431	15U662	LABEL, identification	1
404	117553	SWITCH, disconnect, phase	1	432		MARKER, block, terminal	2
		expander; 100A		433		MARKER, block, terminal	2
405	15U423	SWITCH; 25A	4	434	112948	SCREW, machine head	1
406	255047	BUSHING, strain relief, m40 thread	1	435	100166	NUT, full hex	1
407	255048	NUT, strain relief; M40 thread	1	436*	15R344	LABEL, identification, wiring	1
408	116171	BUSHING, strain relief	2	437▲	196548	LABEL, caution	1
409	117745	BUSHING, strain relief	1	438*		SCHEMATIC, wiring	1
410	117625	NUT, locking	1	439	558685	WASHER, 1/4 external	1
411	15U543	PLUG, hole; 7/8 in.	1				
412	15U544	PLUG, hole; 1 1/8 in.	3				
413	117666	TERMINAL, ground	1				
414	115942	NUT, hex, flange head	1				
415		RAIL, mounting; 3 in.	1				
416		RAIL, mounting	1				
417	255045	BLOCK, clamp end	4				
419		COVER, end	2				
420	255050	CIRCUIT BREAKER; 25A	2				
421	121623	CIRCUIT BREAKER; 10A	2				
422	120570	BLOCK, terminal	9				
425		BAR, power bus, 6 pin	1				
426	117679	CONNECTOR, power lug	2				
427	120573	BRIDGE, plug-in	4				

▲ Replacement Danger and Warning labels, tags, and cards are available at no cost.

* Not shown.

Fluid Control Assembly Parts

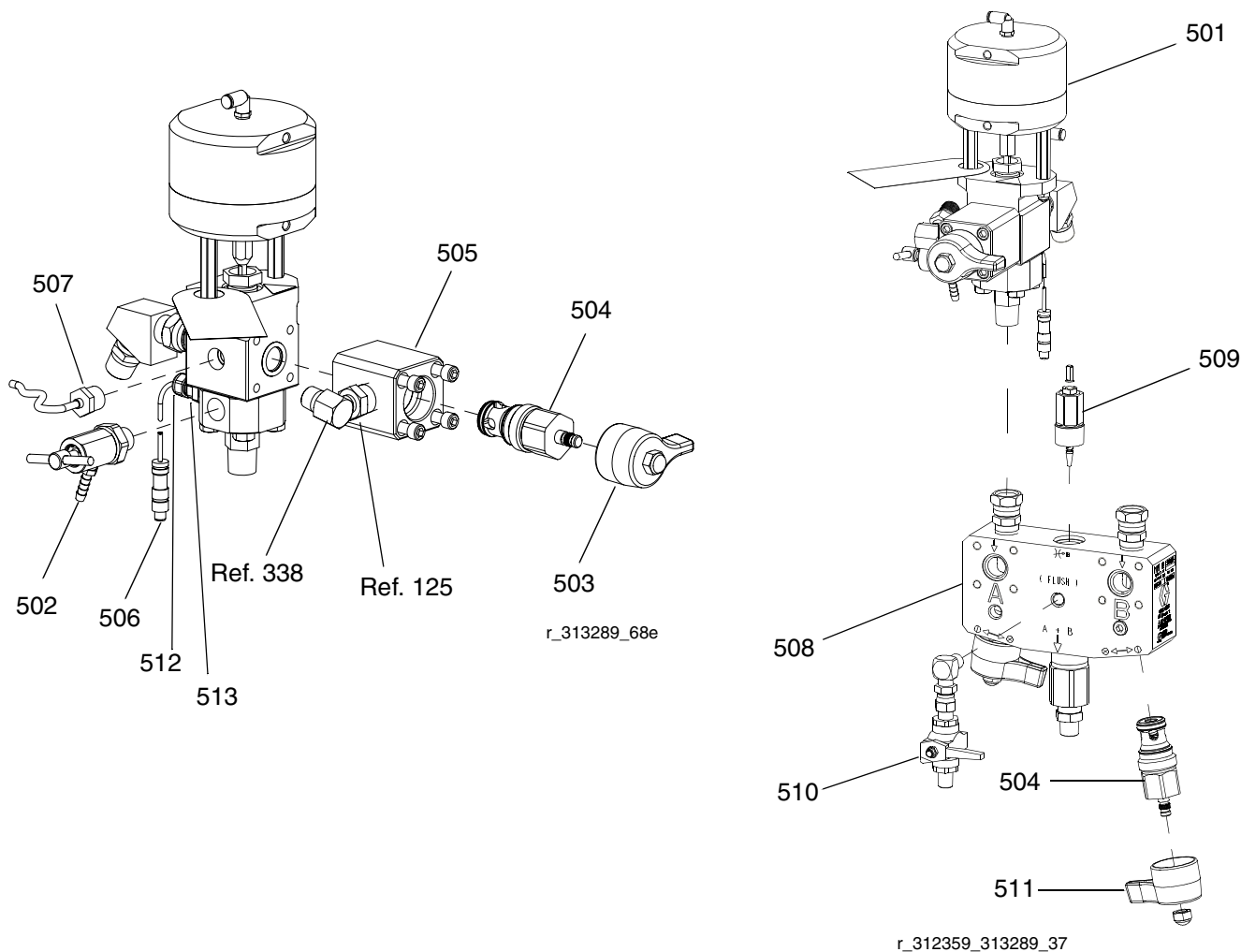

Ref.	Part	Description	Qty.
501✳	255478	VALVE, dosing	2
502‡	245143	VALVE, sampling	2
503✳	15R381	HANDLE, valve, recirculation (black)	2
504✳*	255747	CARTRIDGE, valve, check	4
505✳	15J594	HOUSING, valve, check	2
505a	121139	O-RING, valve; PTFE	2
506	15R347	SENSOR, RTD	2
507	15M669	SENSOR, fluid, pressure	2
507a	121399	O-RING, transducer, pressure	2
508◆	255684	MANIFOLD, mix, assy	1
509◆		VALVE, restrictor, assy	1
510◆	214037	VALVE, solvent, shutoff, assy	1
511◆		HANDLE, valve, mix manifold (blue and green)	2
512	15T072	GRIP, cord	2
513	15T071	FITTING, thermo-well	2

✳ See Dosing Valve manual 313342 for more information.

‡ See Xtreme Displacement Pumps manual 311762 for more information. Repair kit 245145 is available for order.

✳ See High Flow Severe Duty Shutoff Check Valve manual 313343 for more information.

◆ See XM Mix Manifold Kits manual 312749 for more information and part numbers.

* Seal kit 256239 is available for order.

Air Inlet Manifold (255762) Parts

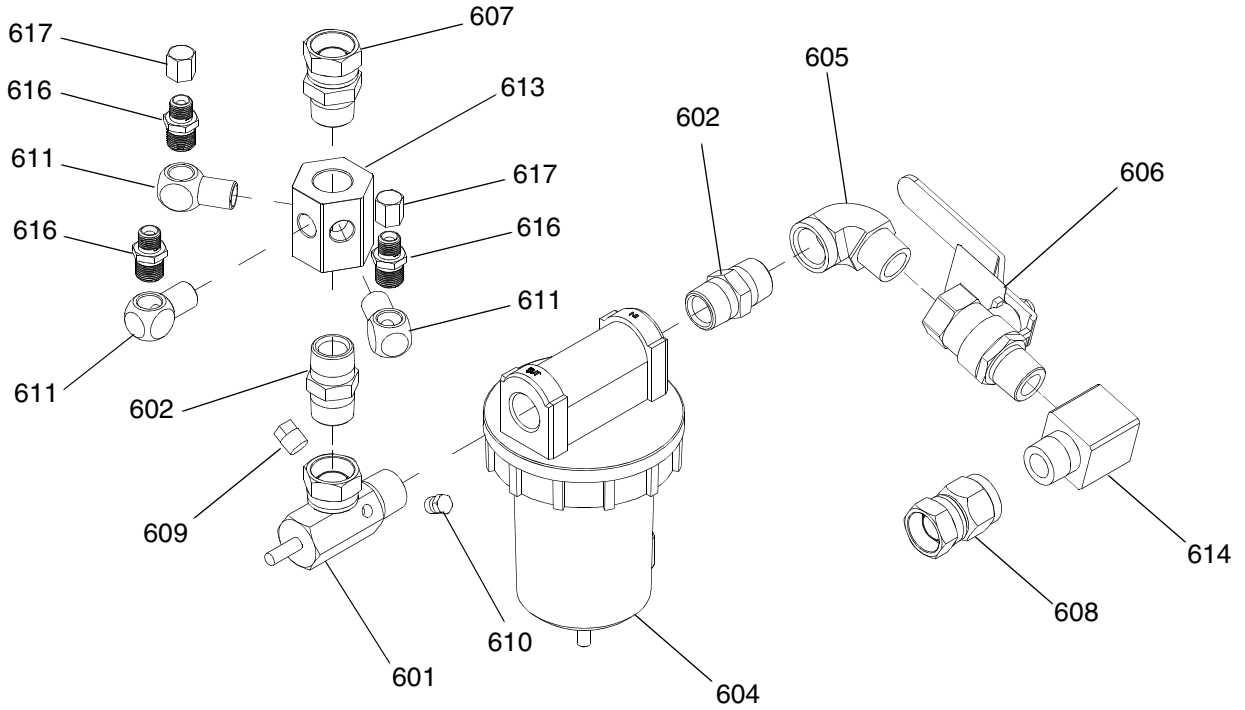

r_xm1a00_312359_313289_21a

Ref.	Part	Description	Qty.
601	207675	MANIFOLD, air	1
602	119992	PIPE, NIPPLE; 3/4 x 3/4 npt	2
603	15E145	MANIFOLD, air distribution	1
604	117628	FILTER, air, auto drain; 3/4 npt	1
604a*	106204	ELEMENT, filter; 3/4 npt	
605	122327	ELBOW, pipe, male	1
606	113218	VALVE, ball, vented	1
607	157785	SWIVEL	1
608	156172	UNION, swivel	1
609	100509	PLUG, pipe	1
610	114234	PLUG, hex head	1
611	155699	ELBOW, street	3
614	166590	ELBOW, street	1
616	157350	ADAPTER	3
617	115781	CAP PLUG	2

* Not shown.

Alternator Module (255728) Parts

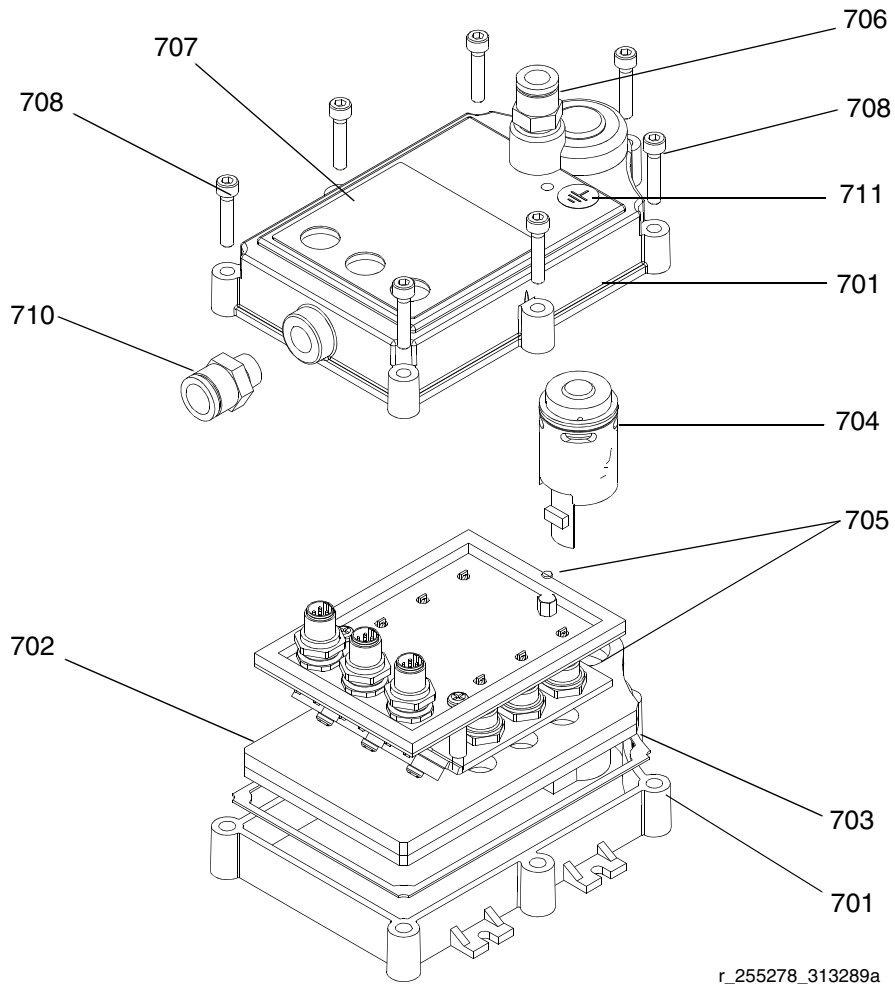

r_255278_313289a

Ref.	Part	Description	Qty.
701		HOUSING, upper and lower	1
702		GASKET, stacked, internal	1
703		GASKET, housing	1
704	257147	TURBINE	1
705		BOARD, assy.	1
706	122161	FITTING, air	1
707▲	15R337	LABEL, warning	1
708	114380	SCREW, cap, socket head	7
709*	C12508	TUBING, nylon; 2 ft.	-
710	122848	FITTING, air	1
711▲	172953	LABEL, grounding	1

▲ Replacement Danger and Warning labels, tags, and cards are available at no cost.

* Not shown.

Repair and Spare Parts Reference

NOTE:

Part numbers and sub-assemblies may change. See www.graco.com for most current part numbers and manuals.

Ref.	Part	Description	Qty.	Part of Assembly
2	257055	NXT Motor w/linear transducer	2	Motor
2	NXT600	Motor seal kit	2	Motor
2	NXT135	Air Valve seal kit	2	Motor
2	NXT136	Air valve rebuild kit	2	Motor
2a	256893	Linear sensor	2	Motor
60	262478	Mixer housing, no mixer; 1/2 in. ID, 3/8 nptm	2	System
61	248927	Mixer sticks; 1/2 in. x 12 element, package of 25	2	System
64	XTR704	XTR spray gun; 7250 psi; includes 519 RAC tip	1	System
64a	XHD001	RAC guard, housing, replacement	1	System
64b	XHDxxx	RAC tip, seal, gasket, x indicates tip size	1	System
66	L250C4	Xtreme displacement pump L250C3 w/o filter	1	XM50 "A" pump
66	244903	Repair kit with Tuff Stack	1	XM50 "A" pump
66	244853	Repair kit with Xtreme seals	1	XM50 "A" pump
66	L180C4	Xtreme displacement pump L180C3 w/o filter	1	XM70 "A" pump
66	244901	Repair kit with Tuff Stack	1	XM70 "A" pump
66	244851	Repair kit with Xtreme seals	1	XM70 "A" pump
67	L220C4	Xtreme displacement pump L220C3 w/o filter	1	XM50 "B" pump
67	244902	Repair kit with Tuff Stack	1	XM50 "B" pump
67	244852	Repair kit with Xtreme seals	1	XM50 "B" pump
67	L145C4	Xtreme displacement L145C3 w/o filter	1	XM70 "B" pump
67	244900	Repair kit with Tuff Stack	1	XM70 "B" pump
67	244850	Repair kit with Xtreme seals	1	XM70 "B" pump
67a	224458	Filter screens; 30 mesh, package of 2 (optional)	1	Pump
67a	224459	Filter screens; 60 mesh, package of 2 (optional)	1	Pump
67b	244895	Filter o-rings; PTFE, package of 10 (thin)	2	Pump
67b	262484	Filter o-rings; package of 10 (medium), PTFE	2	Pump
67b	262483	Filter o-rings; PTFE, package of 10 (thick)	2	Pump
72	15T258	Wrench, Xtreme pump	1	System
75	206995	TSL; quart bottle	1	System
88	255747	Cartridge, circulation, shut-off, mix manifold valves	4-6	Shut-off/check
88a	256239	Seal kit for cartridge valves	4-6	Shut-off/check
100a	223016	Repair kit for b/p restrictor valve	2	System
147	16A004	Flash drive for USB download; 4 GB	1	Control
204a	15M483	Membrane shields, package of 10	1	Control
209a	121636	Solenoid valve, individual replacement valve with DIN	4	Control
223a	123412	Spare key; one pair	1	Controls
344a	123454	Control filter; 5 micron, replacement element	1	Air controls;
501a	234098	Seal kit; include soft parts, old and new dosing valve	2	Dosing valve
501b	234131	Rebuild kit; includes seals, stem, seat, and air spring	2	Dosing valve
502	245143	Sample valve; complete valve	2	Dosing valve
502a	245145	Sample valve kit; includes o-rings, ball, seat, clip	2	Dosing valve
505b	121139	Circulation valve seal; face o-ring, -210, PTFE	2	Dosing valve
507b	121399	Transducer seal; o-ring, -012, solvent resistant rubber	2	Dosing valve
508a	256238	Repair kit; includes seals, balls, seats, shut-off stems	1	Mix manifold
508b	551387	Fluid gauge, bottom mount; 10,000 psi (690 bar)	1	Mix manifold
508c	114434	Fluid gauge, back mount; 10,000 psi (690 bar)	1	Mix manifold
508d	185416	B-side strainer; 40 mesh (use tool 15T630)	1	Mix manifold
508e	121410	Strainer o-ring; PTFE, -113, strainer restrainer	1	Mix manifold
508f	15T630	Strainer tool (push in 121410 o-ring + shut-off u-cup)	1	Mix manifold
510	214037	Flush valve, ball; 1/4 npt(m) PTFE	1	Mix manifold
604a	106204	Main air filter, element (fits 3/4 npt air filters)	1	Air controls
704	257147	Turbine cartridge (fits 255728 XM or Xtreme Mix)	1	Control

Accessories and Kits



Not all accessories and kits are approved for use in hazardous locations. Refer to the specific accessory and kit manuals for approval details.

20-Gallon Hopper Kit, 255963

One complete double-wall 20-gallon hopper. See manual 312747 for more information.

Hopper Heater Kit (240V), 256257

For heating fluid in a 20-gallon hopper. See manual 312747 for more information.

Universal Hopper Fluid Inlet Kit, 256170

For connecting any of the four lower models included with XM sprayer to a 20-gallon hopper. See manual 312747 for more information.

Universal Hopper Mounting Kit, 256259

For mounting a 20-gallon hopper to the side or back of an XM sprayer. See manual 312747 for more information.

Twistork Agitator Kit, 256274

For mixing viscous materials held within a 20-gallon hopper. See manual 312769 for more information.

T2 Feed Pump Kit, 256275

For supplying viscous material from a 20-gallon hopper to an XM sprayer. See manual 312769 for more information.

5:1 Feed Pump Kit, 256276

For supplying viscous materials from a 20-gallon hopper to an XM sprayer. See manual 312769 for more information.

7-Gallon Hopper and Bracket Kit, 256260

One 7-gallon hopper and mounting brackets. Mounts to the side or back of an XM sprayer. See manual 406999 for more information.

2:1 Drum Feed Kit, 256232

One T2 pump feed kit and one Twistork agitator kit for mixing and supplying viscous materials from a with 55-gallon drum to an XM sprayer. See manual 312769 for more information.

5:1 Drum Feed Kit, 256255

One 5:1 pump feed kit and one Twistork agitator kit for mixing and supplying viscous materials from a with 55-gallon drum to an XM sprayer. See manual 312769 for more information.

Hopper/Hose Heat Circulation Kit, 256273

For circulating heated water mixture through 20-gallon hoppers, heated hose, and Viscon HP heater. See manual 313259 for more information.

Desiccant Dryer Kit, 256512

For use with 20-gallon hoppers. See manual 406739 for more information.

Caster Kit, 256262

For mounting casters on XM sprayer frame. See manual 406690 for more information.

Hose Rack Kit, 256263

For mounting to side, front, or back of XM sprayer frame. See manual 406691 for more information.

Lower Strainer and Valve Kit, 256653

For straining material from a feed pump to an XM sprayer fluid inlet. See manual 312770 for more information.

Electric Heated Hose Power Supply Kit, 256876

For monitoring and controlling fluid temperature in low-voltage heated hoses. See manual 313258 for more information.

5000 psi Two-Component Main Heated Hose Set Kit

Electric heated hose set for adding additional sections.

Part	Description
248907	Heated hose set; 1/4 in. ID x 3/8 in. ID; 50 ft.
248908	Heated hose set; 3/8 in. ID x 3/8 in. ID; 50 ft.

10:1 Drum Feed Kit, 256433

For supplying highly viscous material from a 55-gallon drum to an XM sprayer. See manual 312769 for more information.

Shutoff/Check Valve Kit, 255278

For replacing shutoff valve or check valve. See manual 313343 for more information.

Alternator Conversion Kit, 256991

For converting an XM sprayer from wall power supply to intrinsically safe alternator power supply. See manual 313293 for more information.

Mix Manifold Kit, 255684

See manual 312749 for more information.

Remote Mix Manifold and Carriage Kit, 256980

For converting to a remote mix manifold kit with a protective guard. See manual 312749 for more information.

Restrictor Valve Kit, 24F284

For B dosing outlet on remote mix manifold machines. Use to convert early XM machines without the valve on the B outlet.

Xtreme Pump Wet Cup Wrench, 15T258

Xtreme Pump Filter Wrench, 16G819

Dimensions

System Dimensions without Hoppers

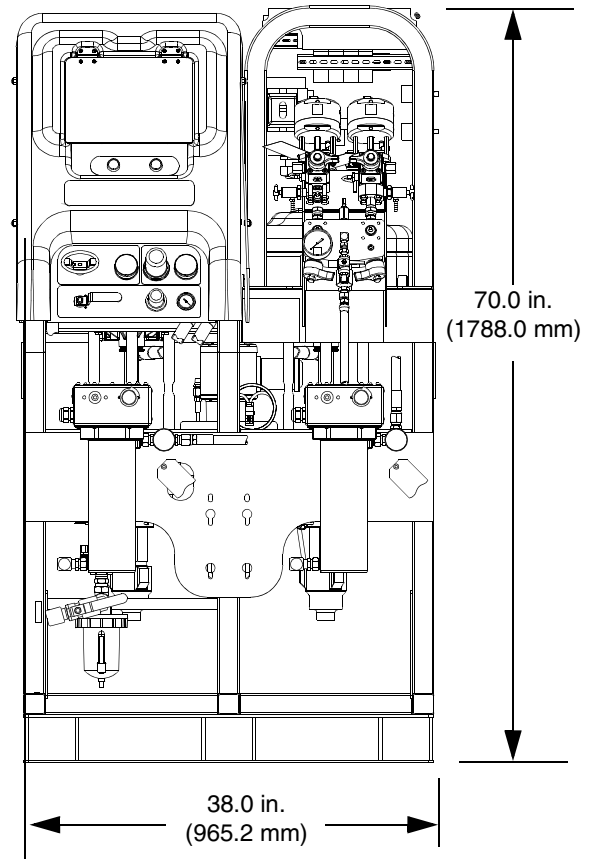
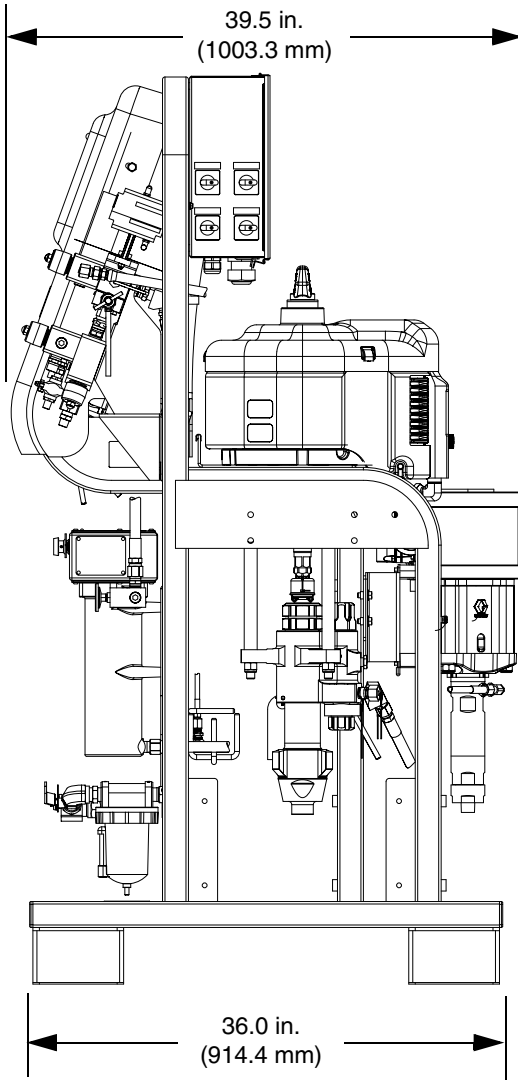

r_xm1a00_312359_313289_12a

r_312359_313289_b_2

System Dimensions with Hoppers

Two 20-Gallon Hoppers Side Mounted

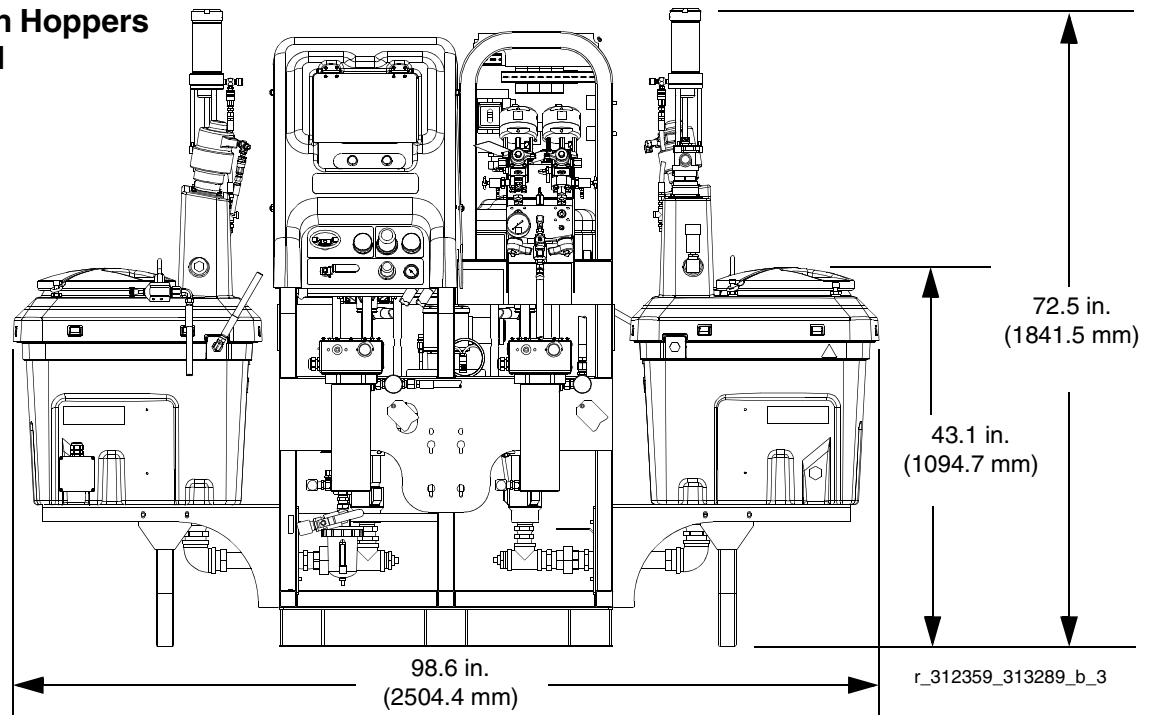

Two 20-Gallon Hoppers Rear Mounted (Top View)

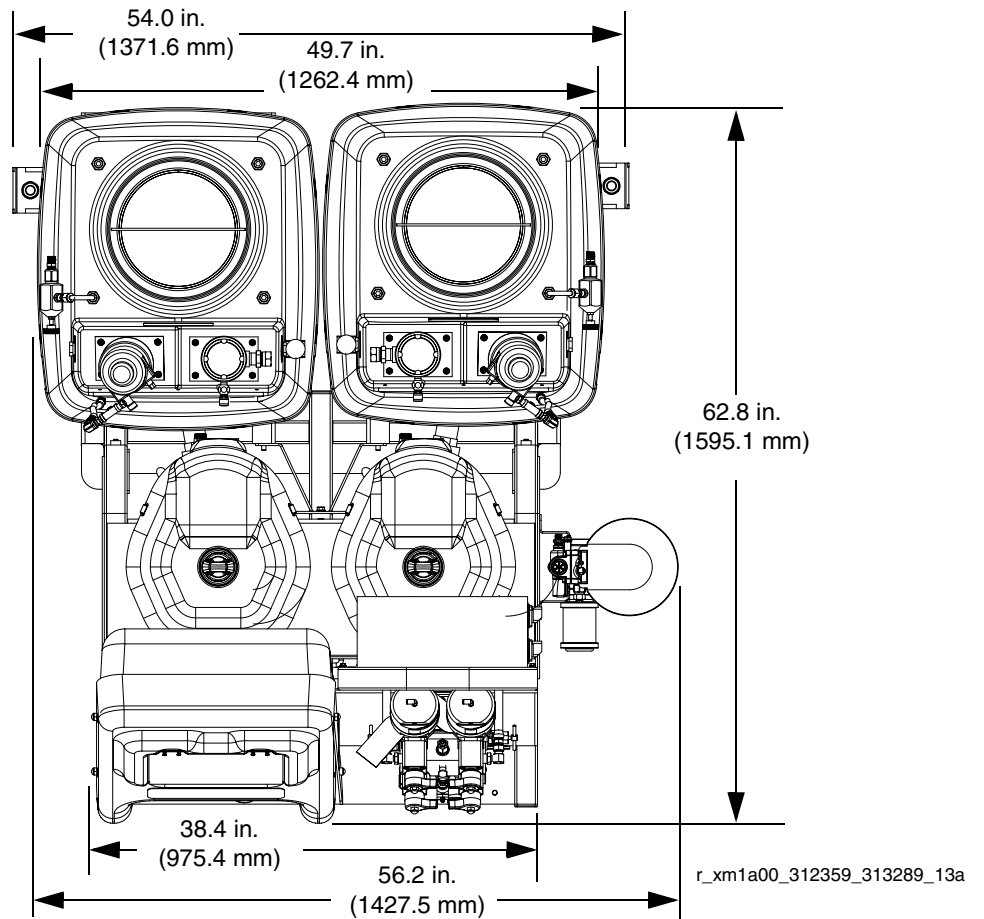

System Dimensions with Hoppers

One 20-Gallon Hopper and One 7-Gallon Hopper

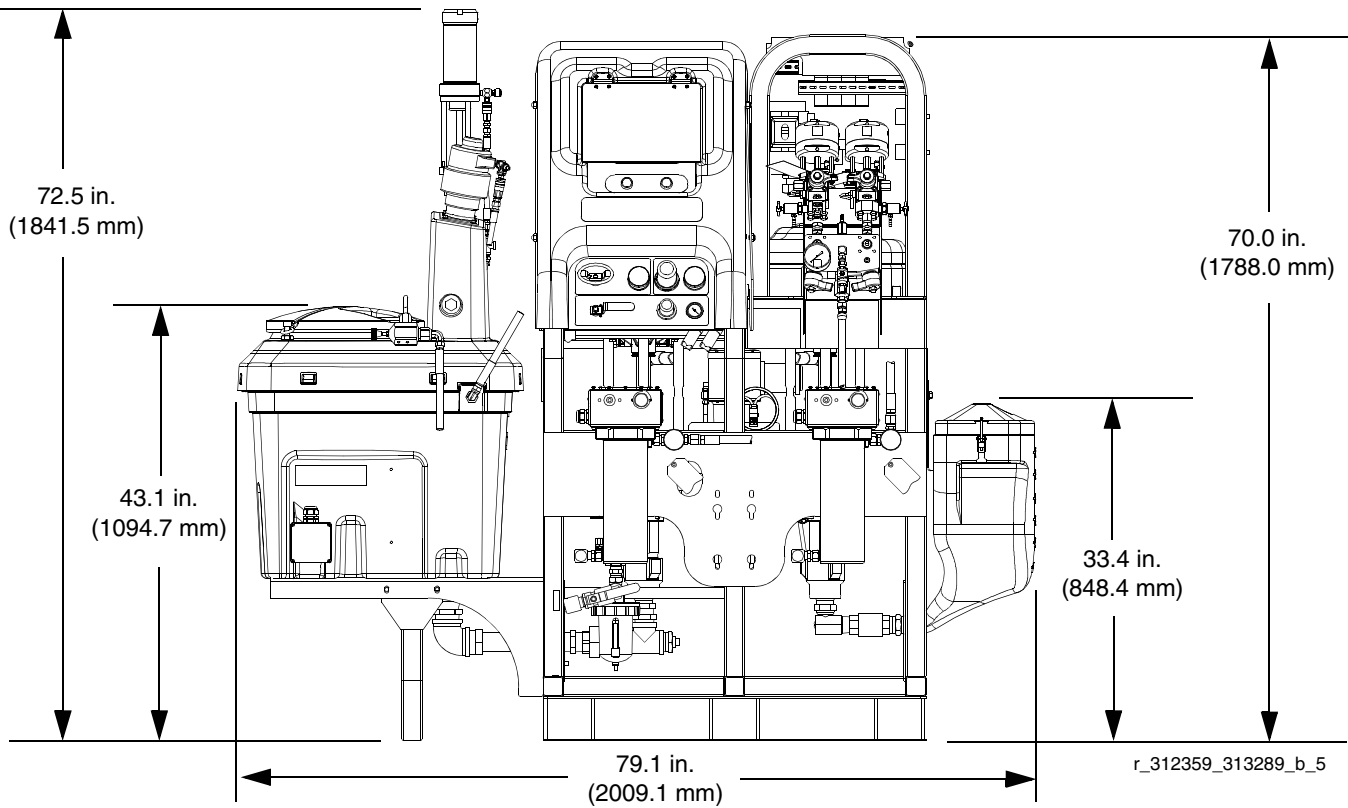

Two 7-Gallon Hoppers

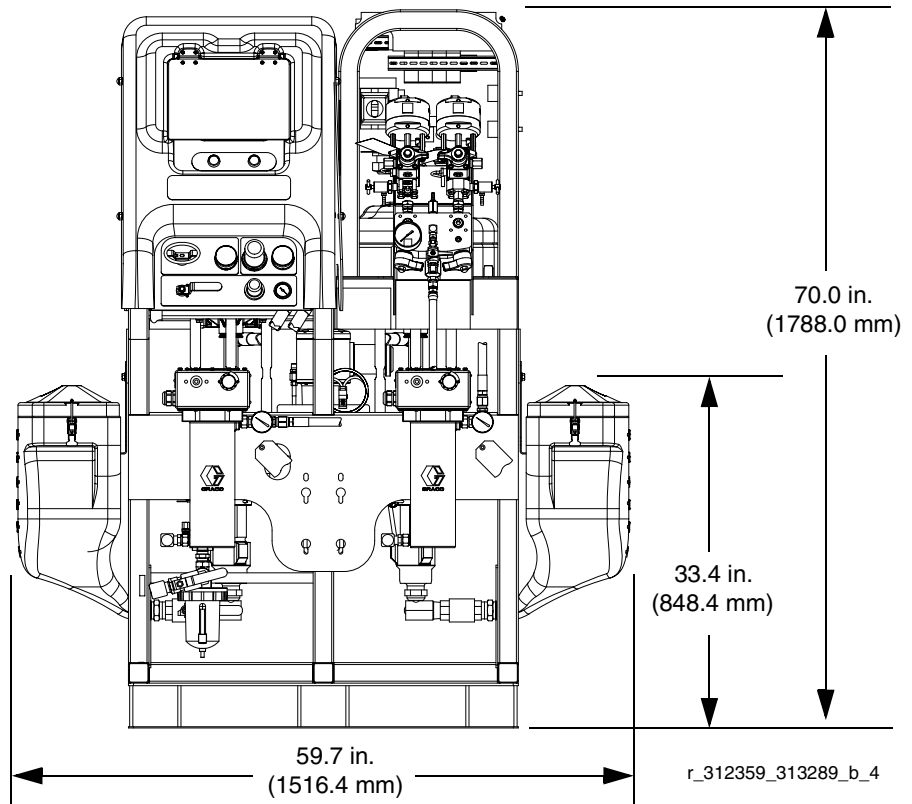

Technical Data

Mixed ratio range	1:1-10:1 (in 0.1 increments)
Ratio tolerance range (before alarm)	+/- 5%
Flow rates	
Minimum	1 qt./min. (0.95 liter/min.)*
Maximum	3 gal./min/ (11.4 liter/min.)
Fluid viscosity range	200-20,000 cps (heavier viscosities can be mixed using heat, circulation, and/or pressure feeding)
Fluid filtration	60 mesh, (238 micron) standard on pump outlets (filter assembly not included on some models)
Air inlet	3/4 npt(f)
Fluid inlets without feed kits	1 1/4 npt(m)
Maximum fluid working pressure of mixed material	
50:1	5200 psi (35.8 MPa, 358 bar)
70:1	6300 psi (43.5 MPa, 435 bar)
Maximum fluid temperature	160° F (71° C)
Air supply pressure range	50-150 psi (0.35-1.0 MPa, 3.5-10.3 bar)
Maximum pump air set pressure	
50:1	105 psi (0.74 MPa, 7.4 bar)
70:1	85 psi (0.60 MPa, 6.0 bar)
Maximum pump inlet fluid feed pressure	250 psi (1.7 MPa, 17 bar)
Maximum air consumption at 100 psi (0.7 MPa, 7.0 bar)	
in scfm (m ³ /min.)	70 scfm per gpm (1.96 m ³ /min. per lpm)
Ambient temperature range	
Operating	32-135° F (0-57° C)
Storage	30-160° F (-1-71° C)
Environmental conditions rating	Indoor/outdoor use Altitude up to 4000 m Maximum relative humidity to 99% up to 130° F (54° C) Pollution degree (11) Installation category (2)
Sound pressure	86 dBA at 100 psi (0.7 MPa, 7 bar)
Sound power	98 dBA at 100 psi (0.7 MPa, 7 bar)
Wetted parts	
Suction tubes	aluminum
Flush pump	carbide, PTFE, stainless steel, UHMWPE
Hoses	nylon
Pumps (A and B)	carbon steel, alloy steel, 303, 440, 17-ph grades stainless steel, zinc and nickel plating, ductile iron, tungsten carbide, PTFE
Metering valves	carbon steel, nickel plating, carbide, polyethylene, leather
Manifold	carbon steel, nickel plating, carbide, 302 stainless steel, PTFE, UHMWPE
Mixer	stainless steel housing with acetal elements
Spray gun	Refer to spray gun manual
Dimensions	See Dimensions , page 82
Weight	Base sprayer (XM1A00 and XM5A00 models) 742 lbs (336.87 kg) (Add component weight(s) to base sprayer weight for your specific model weight. See component manuals.)

* Minimum flow rate is dependent on material being sprayed and mixing capability. Test your material specific to flow rate.

Graco Standard Warranty

Graco warrants all equipment referenced in this document which is manufactured by Graco and bearing its name to be free from defects in material and workmanship on the date of sale to the original purchaser for use. With the exception of any special, extended, or limited warranty published by Graco, Graco will, for a period of twelve months from the date of sale, repair or replace any part of the equipment determined by Graco to be defective. This warranty applies only when the equipment is installed, operated and maintained in accordance with Graco's written recommendations.

This warranty does not cover, and Graco shall not be liable for general wear and tear, or any malfunction, damage or wear caused by faulty installation, misapplication, abrasion, corrosion, inadequate or improper maintenance, negligence, accident, tampering, or substitution of non-Graco component parts. Nor shall Graco be liable for malfunction, damage or wear caused by the incompatibility of Graco equipment with structures, accessories, equipment or materials not supplied by Graco, or the improper design, manufacture, installation, operation or maintenance of structures, accessories, equipment or materials not supplied by Graco.

This warranty is conditioned upon the prepaid return of the equipment claimed to be defective to an authorized Graco distributor for verification of the claimed defect. If the claimed defect is verified, Graco will repair or replace free of charge any defective parts. The equipment will be returned to the original purchaser transportation prepaid. If inspection of the equipment does not disclose any defect in material or workmanship, repairs will be made at a reasonable charge, which charges may include the costs of parts, labor, and transportation.

THIS WARRANTY IS EXCLUSIVE, AND IS IN LIEU OF ANY OTHER WARRANTIES, EXPRESS OR IMPLIED, INCLUDING BUT NOT LIMITED TO WARRANTY OF MERCHANTABILITY OR WARRANTY OF FITNESS FOR A PARTICULAR PURPOSE.

Graco's sole obligation and buyer's sole remedy for any breach of warranty shall be as set forth above. The buyer agrees that no other remedy (including, but not limited to, incidental or consequential damages for lost profits, lost sales, injury to person or property, or any other incidental or consequential loss) shall be available. Any action for breach of warranty must be brought within two (2) years of the date of sale.

GRACO MAKES NO WARRANTY, AND DISCLAIMS ALL IMPLIED WARRANTIES OF MERCHANTABILITY AND FITNESS FOR A PARTICULAR PURPOSE, IN CONNECTION WITH ACCESSORIES, EQUIPMENT, MATERIALS OR COMPONENTS SOLD BUT NOT MANUFACTURED BY GRACO. These items sold, but not manufactured by Graco (such as electric motors, switches, hose, etc.), are subject to the warranty, if any, of their manufacturer. Graco will provide purchaser with reasonable assistance in making any claim for breach of these warranties.

In no event will Graco be liable for indirect, incidental, special or consequential damages resulting from Graco supplying equipment hereunder, or the furnishing, performance, or use of any products or other goods sold hereto, whether due to a breach of contract, breach of warranty, the negligence of Graco, or otherwise.

FOR GRACO CANADA CUSTOMERS

The Parties acknowledge that they have required that the present document, as well as all documents, notices and legal proceedings entered into, given or instituted pursuant hereto or relating directly or indirectly hereto, be drawn up in English. Les parties reconnaissent avoir convenu que la rédaction du présente document sera en Anglais, ainsi que tous documents, avis et procédures judiciaires exécutés, donnés ou intentés, à la suite de ou en rapport, directement ou indirectement, avec les procédures concernées.

Graco Information

For the latest information about Graco products, visit www.graco.com.

TO PLACE AN ORDER, contact your Graco distributor or call to identify the nearest distributor.

Phone: 612-623-6921 **or Toll Free:** 1-800-328-0211 **Fax:** 612-378-3505

*All written and visual data contained in this document reflects the latest product information available at the time of publication.
Graco reserves the right to make changes at any time without notice.*

Original instructions. This manual contains English. MM 313289

Graco Headquarters: Minneapolis

International Offices: Belgium, China, Japan, Korea

GRACO INC. AND SUBSIDIARIES • P.O. BOX 1441 • MINNEAPOLIS MN 55440-1441 • USA

Copyright 2009, Graco Inc. All Graco manufacturing locations are registered to ISO 9001.

www.graco.com
Revised 10/2011