

INSTRUCTIONS



684-026

Revision C



This manual contains important warnings and information.
READ AND RETAIN FOR REFERENCE

Instructions

Air-Powered Premier Hydra-Cat[®] H.P. Variable Ratio Proportioning Pump

100 PSI (6.8 bar) Maximum Working Air Pressure

5000 PSI (333 bar) Maximum Working Fluid Pressure

Model: See Chart

Assembly Part #	Ratio Min.	Ratio Max.
965-481	1.50	4.50
965-479	2.00	6.00
965-530	1.00	3.00
965-579	1.33	4.00
965-480	1.00	3.00

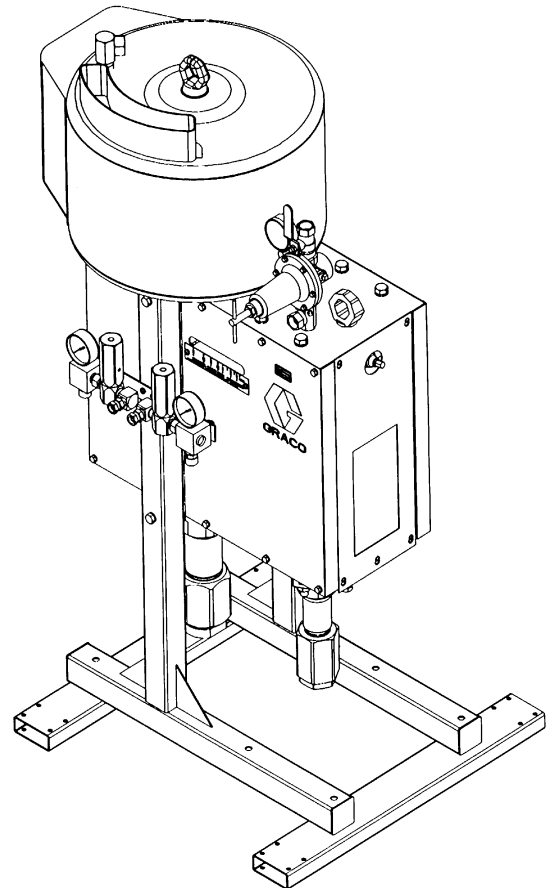

WARNING

MOVING PARTS HAZARD

Relieve fluid and air pressure to unit before servicing unit. Do not operate with panels removed. Follow pressure relief procedure on page 11.

WARNING

Graco Inc. does not manufacture or supply any of the reactive chemical components that are used in this equipment and is not responsible for their effects. Because of the vast number of chemicals that could be used and their varying chemical reactions, the buyer and user of this equipment should determine all factors relating to the fluids used, including any of the potential hazards involved. Particular inquiry and investigation should be made into potential dangers relating to toxic fumes, fires, explosions, reaction times, and exposure of human beings to the individual components or their resultant mixtures. Graco assumes no responsibility for loss, damage, expense or claims for bodily injury or property damage, direct or consequential, arising from the use of such chemical components.

GRACO INC.

P.O. BOX 1441

MINNEAPOLIS, MN

55440-1441

©Copyright 1998 Graco Inc.

Table of Contents

Symbols.....	3	Operation.....	11
Definition of Terms	3	Pressure Relief Procedure.....	11
Warnings	3	System Flushing.....	11
Specification of Hydra-Cat H.P. Pumps	6	Start the Pump	11
Installation	6	Standard Operating Flushing	11
Connect the Fluid Supply Line	6	Checking the Ratio.....	12
Connect the Fluid Output Lines	6	Maintenance	12
System Accessories.....	7	Wet Cups	12
Connect the Air Supply Line.....	7	Bearings	12
Pressure Relief Valve	7	Air Lubrication	13
Electrical Grounding.....	8	Troubleshooting.....	14
Ratio Adjustment	9	Troubleshooting Techniques.....	14
Terms.....	9	Troubleshooting Chart	15
Determine the Ratio	10	Service.....	16
Relationship Between the Primary and		Required Tools.....	16
Secondary Pumps	10	Disconnecting the Displacement Pump	16
Adjusting the Ratio Setting.....	10	Reconnecting the Displacement Pump.....	17
		Disconnecting the Air Motor	17
		Reconnecting the Air Motor.....	17
		Replacing the Bearings.....	18
		Dimensions.....	19
		Air Consumption	19
		Technical Data.....	21
		Graco Phone Numbers.....	22
		The Graco Warranty and Disclaimers	22

Symbols

Warning Symbol

WARNING

This symbol alerts you to the possibility of serious injury or death if you do not follow the instructions

Caution Symbol

CAUTION

This symbol alerts you to the possibility of damage to or destruction of equipment if you do not follow the instructions.

Definition of Terms

WARNING: Alerts the user to avoid or correct conditions which could cause serious injury.

CAUTION: Alerts the user to avoid or correct conditions which could damage or destroy equipment.

NOTE: Identifies helpful information.

VRHC: The abbreviation for Variable Ratio Hydra-Cat Pump. This pump automatically proportions and mixes two fluids in a prescribed ratio, which is variable within the ranges listed on the cover.

BASE: Also called polyol or resin, is one of two reactive chemicals used in a plural component system.

CATALYST: Also called hardener, is the fluid which reacts with the base fluid.

PART: An undefined unit of measurement. When you determine the size of the unit (ounce, pint, gallon), use that measurement consistently in setting up your system.

SPRAY GUN: This term refers to any type of spray gun or dispensing valve used to spray or dispense the fluid being pumped.

WARNING



PLURAL COMPONENT FLUID HAZARD

Before using this equipment, read the fluid manufacturer's warnings and determine all facts relating to the fluids used, including any of the potential hazards relating to toxic fumes, fires, explosions, reaction times, and exposure of human beings to the individual components of their resultant mixtures.

- Store hazardous fluid in an approved container. Dispose of hazardous fluid according to all local, state and national guidelines.
- Wear the appropriate protective clothing, gloves, eyewear, and respirator.
- Graco does not manufacture or supply any of the reactive chemical components that may be used in this equipment and is not responsible for their effects. Graco assumes no responsibility for loss, damage, expense or claims for personal injury or property damage, direct or consequential, arising from the use of such chemical components.



MOVING PARTS HAZARD

Moving parts, such as the air motor piston and the secondary pump lever and connecting rod area, can pinch or amputate fingers.

- Do not operate the equipment with the guards removed.
- Keep your body and tools clear of any moving parts when starting or operating the equipment.

WARNING



FIRE AND EXPLOSION HAZARD

Improper grounding, poor ventilation, open flames, or sparks can cause a hazardous condition and result in fire or explosion and serious injury.



- Ground the equipment and the object being sprayed. See **Electrical** Grounding on page 8.
- Extinguish all the open flames or pilot lights in the spray area.
- Electrically disconnect all equipment in the spray area.
- Keep the spray area free of debris, including solvent, rags, and gasoline.
- Do not turn on or off any light switch in the spray area while operating or if fumes are present.
- Do not smoke in the spray area.
- Do not operate a gasoline engine in the spray area.
- If there is any static sparking while using this equipment, **stop spraying immediately**. Identify and correct the problem.



INSTRUCTIONS

EQUIPMENT MISUSE HAZARD

Equipment misuse can cause the equipment to rupture, malfunction, or start unexpectedly and result in serious injury.

- This equipment is for professional use only.
- Read all instruction manuals, tags, and labels before operating the equipment.
- Use the equipment only for its intended purpose. If you are uncertain about the usage, call Graco Technical Assistance at 1-800-543-0339.
- Do not alter or modify this equipment. Use only genuine Graco parts and accessories.
- Check the equipment daily. Repair or replace worn or damaged parts immediately.
- All system components must meet or exceed the pressure ratings printed on the pressure relief valve. The lever amplification or the secondary pump enables very high fluid pressures to be achieved. A 5000 psi working pressure range relief valve is required on both cylinders to limit the fluid pressure. Do not tamper with the pressure relief valve or serious bodily injury could result.
- Do not lift pressurized equipment.
- Route the hoses away from the traffic areas, sharp edges, moving parts, and hot surfaces. Do not expose Graco hoses to temperatures above 180°F (82°C) or below -40°F (-40°C).
- Do not use hoses to pull equipment.
- Use fluids or solvents that are compatible with the equipment wetted parts. See the **Technical Data** section of all the equipment manuals. Read the fluid and solvent manufacturer's warnings.
- Fluid hoses must have spring guards on both ends to protect them from rupture caused by kinks or bends near the couplings.
- Comply with all applicable local, state, and national fire, electrical, and safety regulations.

WARNING



INJECTION HAZARD

Spray from the spray gun, hose leaks or ruptured components can inject fluid into your body and cause extremely serious injury, including the need for amputation. Splashing fluid in the eyes or on the skin can also cause serious injury.

- Fluid injected into the skin might look like just a cut, but it is a serious injury. **Get immediate medical attention.**
- Do not point the gun at anyone or at any part of the body.
- Do not put your hand or fingers over the spray tip.
- Do not stop or deflect leaks with your hand, body, glove or rag.
- Do not “blow back” fluid; this is not an air spray system.
- Always have the tip guard and the trigger guard on the spray gun (if so equipped) when spraying.
- Check the spray gun diffuser (if so equipped) operation weekly. Refer to the gun manual.
- Be sure the spray gun trigger safety operates before operating the gun.
- Lock the spray gun trigger safety when you stop spraying.
- Follow the **Pressure Relief Procedure** on page 11 when you are instructed to relieve pressure, stop spraying, check, clean or service any system equipment, or install or change spray tips.
- Tighten all fluid connections before each use.
- Check the hoses, tubes, and couplings daily. Replace worn or damaged parts immediately. Permanently coupled hoses cannot be repaired.
- Handle and route hoses and tubes carefully. Keep hoses and tubes away from moving parts and hot surfaces. Do not use the hoses to pull equipment. Do not expose Graco hoses to temperatures above 180°F (82°C) or below -40°F (-40°C).

Specifications of Hydra-Cat H.P. Pumps

The following chart gives specifications for the Hydra-Cat H.P. pumps, using No. 10 weight oil. The volumetric ratio is expressed as the proportion of the volume of fluid of the primary pump compared to the volume of fluid of the secondary pump.

For example, Model 965-480 has a minimum volumetric ratio of 1:1. At this setting the primary and secondary pumps combined will deliver an output of 6.1 gpm. The maximum volumetric ratio for Model 965-480 is 3:1 and the combined output at that setting is 4.1 gpm.

Air Motor	Assembly Part No.	Ratio		At Minimum Ratio Setting				At Maximum Ratio Setting				Lower ID	
		Min	Max	Stall PSI	Stall Bar	Output GPM	Output LPM	Stall PSI	Stall Bar	Output GPM	Output LPM	Master DF	Slave DF
Premier	965-481	1.50	4.50	5333	368	3.8	14.4	7273	502	2.8	10.6	9	6
Premier	965-479	2.00	6.00	4444	307	4.6	17.3	5714	394	3.6	13.4	12	6
Premier	965-530	1.00	3.00	4444	307	4.6	17.3	6667	460	3.0	11.5	9	9
Premier	965-579	1.33	4.00	3810	263	5.3	20.2	5333	368	3.8	14.4	12	9
Premier	965-480	1.00	3.00	3333	230	6.1	23.0	5000	345	4.1	15.4	12	12
King	965-477	1.00	3.00	3803	262	3.0	11.5	5704	393	2.0	7.7	6	6
King	965-478	1.50	4.50	3042	210	3.8	14.4	4148	286	2.8	10.6	9	6
King	965-524	2.00	6.00	2535	175	4.6	17.3	3259	225	3.6	13.4	12	6
King	965-466	3.00	9.00	1901	131	6.1	23.0	2282	157	5.1	19.2	18	6

Note: All Output Pressures Limited To 5000 PSI By Integral Pressure Relief Valves

Note: Pressure outputs calculated at 100 PSI Air Pressure for Premier and 90 PSI Air Pressure for King

Note: Volume outputs calculated at 40 cycles per minute.

Installation

The Typical Installation shown is only a guide to setting up the complete Hydra-Cat H.P. system. For assistance in designing a system to suit your particular needs, contact your nearest Graco representative.

NOTE: The reference numbers and letters in the text correspond to the numbers and letters in the drawings.

Location

Sit the proportioner on a flat floor surface.

Connect the Fluid Supply Lines

Connect the grounded fluid hoses to the pump inlet fittings (P, R). If the unit will be pressure fed from separate supply units, install a fluid pressure gauge at each inlet.

NOTE: The pressurized fluid supplies must not exceed 1/4 of the operating fluid pressure of the pump. Pressure above that level will feed right through the pump and improper rationing will result.

Connect the Fluid Output Lines

Connect electronically conductive fluid hoses to the pump outlet fittings. Tighten all of the fittings.

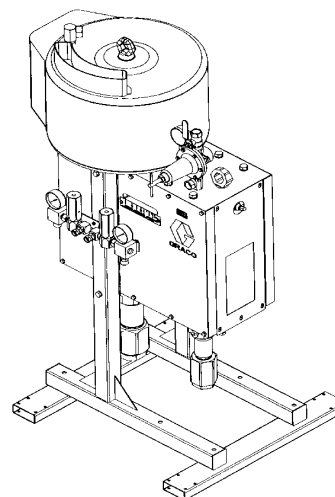

Fig. 1

KEY

- A Bleeder Type Main Air Valve
- B Air Regulator
- C Pressure Relief Valve
- D Mix Manifold
- E Air Supply Line
- F Air Line Filter
- G Air Shutoff Valve
- H Air Line Lubricator
- J Base Supply Pump
- K Catalyst Supply Pressure Pot
- L Solvent Supply Pump
- M Mix Manifold Flush Inlet
- N Static Mixer
- P Primary Pump Inlet
- R Secondary Pump Inlet
- S Ratio Adjustment Screw
- T Spray Gun
- U Ratio Indicator Plate
- V Ratio Indicator Pin

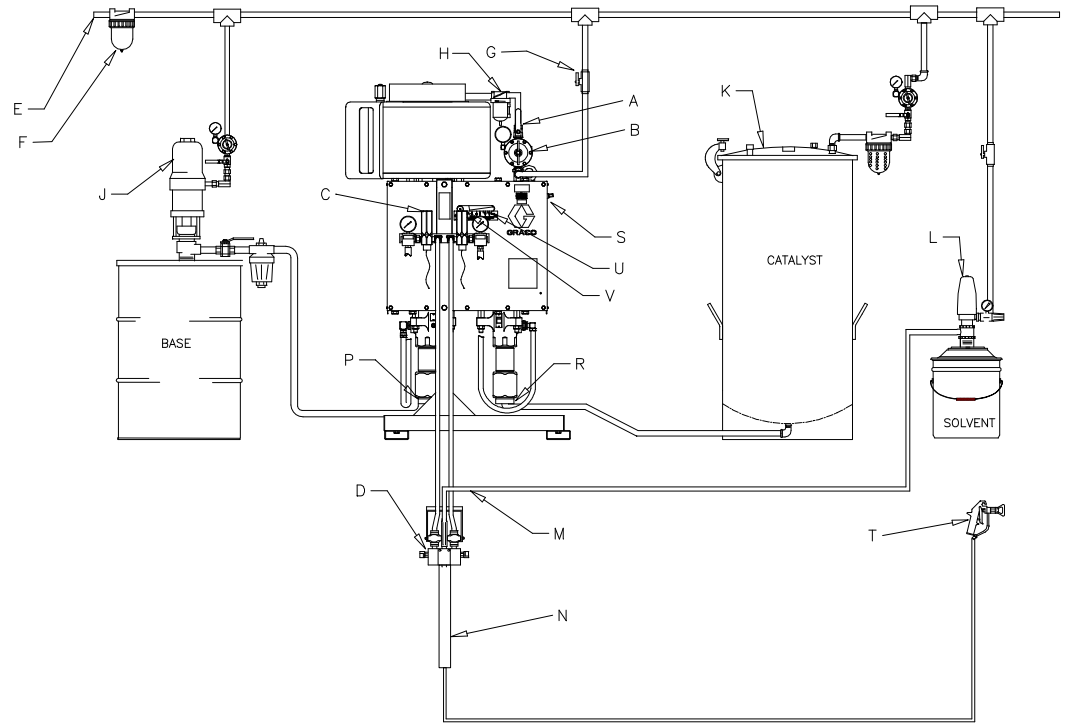

Fig. 2 Typical Installation

System Accessories

Refer to Fig. 2.

NOTE: To ensure the maximum pump performance and safety, be sure that all the accessories used are properly sized to meet your system requirements and the pressure limits of the pump. Use only genuine Graco parts and accessories.

In the air line, install an air filter (F) to remove harmful dirt and moisture from the compressed air supply. Install an air line lubricator (H) downstream from the air filter, the air regulator (B) and the bleed-type master air valve (A). A lubricator will provide automatic lubrication to the air motor.

WARNING

A bleed-type master air valve (A) is required in your system to relieve the air trapped between the valve and the pump after the pump is shut off. Trapped air can cause the pump to cycle unexpectedly, resulting in possible serious injury, including amputation.

Connect the Air Supply Line

Connect an electrically conductive air supply hose to the 3/4" npt(f) port of the air manifold (B). Open the bleed-type master air valve (A) and, using the pressure gauge, set the air regulator (B) to the desired pressure. See the Typical Installation and the Parts Drawing.

Pressure Relief Valve

All components have rated working pressures of 5000 psi (345 bar) or greater. For more information about the pressure relief valve, see instruction manual 308-547.

Electrical Grounding

WARNING



FIRE AND EXPLOSION HAZARD

Static electricity is created by the high velocity flow of fluid through the pump and hose. If your system is not properly grounded, sparking may occur and the system may become hazardous.



To reduce the risk of static sparking which can result in a fire or explosion and cause serious injury, follow these recommendations for providing electrical continuity throughout your system.

Also, read the WARNING section, **FIRE AND EXPLOSION HAZARD** on page 4.

1. *Pump:* Loosen the grounding lug locknut (A) and washer. Insert one end of a 12 ga (1.5 m²) minimum ground wire (B) into the slot in the lug (C). Tighten the locknut securely. See Fig. 3. Connect the other end of the ground wire to a true earth ground. Order a Grounding Clamp, P/N 103-538, and a Grounding Wire, P/N 208-950, (25 feet (7.6 m) long, 12 ga.).
2. *Air and fluid hoses:* Use only electrically conductive hoses with a maximum of 500 feet (150 m) combined hose length to ensure grounding continuity.
3. *Air compressor:* follow the air compressor manufacturer's recommendations

4. *Spray gun or dispensing valve:* Obtain grounding through connection to a properly grounded fluid hose and pump.
5. *Fluid supply container:* according to your local code.
6. *Object being sprayed:* according to local code.
7. *All solvent pails* used when flushing, according to local code. *Use only metal pails* which are conductive, placed on a positively grounded surface. Do not place the pail on a non-conductive surface, such as paper or cardboard, which interrupts the grounding continuity.
8. *To maintain grounding continuity when flushing or relieving pressure,* always hold a metal part of the gun or dispensing valve firmly to the side of a grounded metal pail, then trigger the gun.

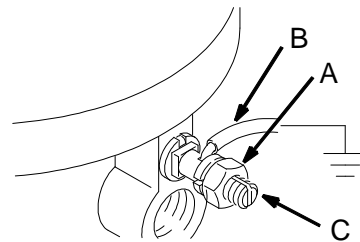

Fig. 3

0720

Ratio Adjustment

Understanding the terms used with the **Hydra-Cat (H.P.) System**, how it functions, and how to find and set the correct **ratios** for your application is the key to easier, more versatile operation of your proportional system.

Be sure to read and understand the following information before operating the equipment.

Terms

Ratio refers to the simultaneous output of a certain volume of fluid by the **primary** and **secondary pumps**.

The **primary pump (A)** is directly under the **air motor (H)**; it usually pumps the **base fluid**. The **secondary pump (B)** is on the opposite end of the **lever arm (E)**; it usually pumps the **catalyst**. The ratio of the secondary pump(s) can be changed by adjusting the **ratio adjustment screw (C)**. See Fig. 4.

There are three main steps when applying the use of ratios: (1) determine the ratio that is required, (2) calculate the ratio setting, and (3) set the ratio on the Hydra-Cat H.P. system.

Key

A Primary Pump
B Secondary Pump
C Ratio Adjustment Screw

D Wet Cups
E Fulcrum and Arm
F Primary Pump Output
G Secondary Pump Output

H Air Motor
I Air Input
J Bleed Type Master Air Valve

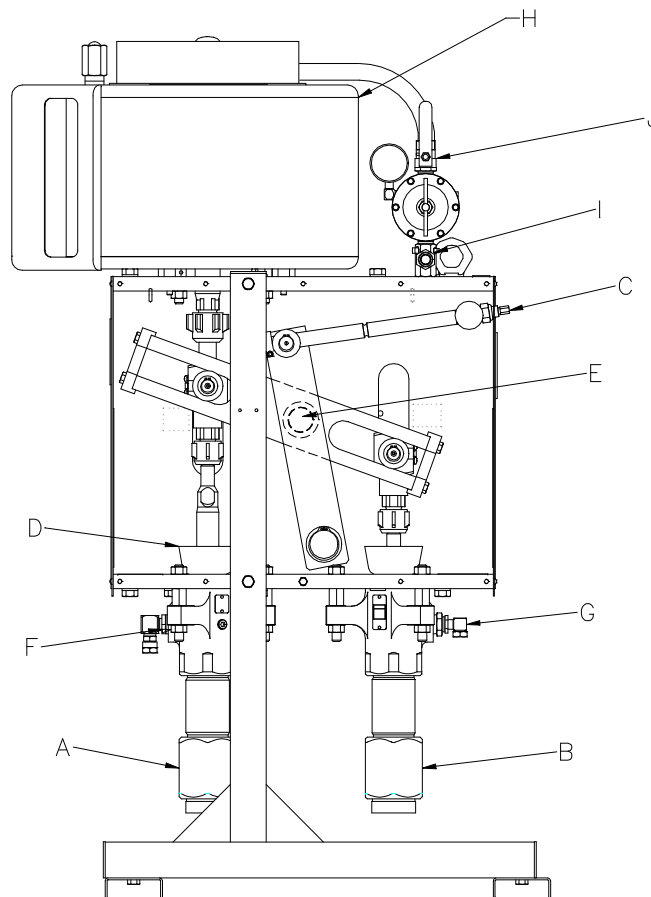

Fig. 4

Determine the Ratio

Set the ratio based on your situation. If :

- The fluids are supplied at a ready-to-spray viscosity, simply set the ratio as explained under **Adjusting the Ratio**.
- The fluids are NOT supplied at ready-to-spray viscosity, the ratio must be determined after the reducer is added to the base, as instructed in **Procedure 1**, below.

NOTE: Evaporation of the reducer in the base causes changes in the ratio. To prevent evaporation, store the base in a closed container.

NOTE: Some reducers have very little ability to lubricate and many cause seals to dry out. To prolong the seal life, be sure your pump seals are compatible with the base's reducer. Contact your Graco representative for the correct seals to use.

Procedure 1: Base is not pre-reduced

When adding the reducer to the base before proportioning with the VRHC system, determine the ratio of the base/reducer mixture to the catalyst in order to set the proper ratio.

Example:

The instructions on the can say "Mix 5 parts base to 1 part catalyst. Then reduce 3 parts of this mixture to 1 part reducer."

1. Add the **parts of the base and catalyst** to find the **parts mixture**.

$$\begin{array}{r}
 5 \quad \text{parts base} \\
 + \quad 1 \quad \text{parts catalyst} \\
 \hline
 6 \quad \text{parts mixture}
 \end{array}$$

2. The next statement on the can says, "Reduce 3 parts of the mixture." So divide the **parts of the mixture** by **3 parts to reduce** to find the **parts reducer**.

$$\begin{array}{r}
 6 \quad \text{parts mixture} \\
 / \quad 3 \quad \text{parts to reduce} \\
 \hline
 2 \quad \text{parts reducer}
 \end{array}$$

3. To determine the ratio of the secondary pump, add the appropriate **parts of base and reducer** to find the **parts combined base/reducer**.

$$\begin{array}{r}
 5 \quad \text{parts base} \\
 + \quad 2 \quad \text{parts reducer} \\
 \hline
 7 \quad \text{parts combined base/reducer to} \\
 \quad \quad 1 \text{ part catalyst}
 \end{array}$$

The **ratio of the pump** is 7:1.

Relationship Between the Primary and Secondary Pumps

Moving the fulcrum point away from the primary pump reduces the secondary stroke length, reducing its fluid output. Moving the fulcrum point closer to the primary pump increases the secondary stroke length, increasing its fluid output.

Fig. 5 shows the relationship between the primary pump and the secondary pump.

Adjusting the Ratio

See Fig. 2. Use a wrench to rotate the ratio adjustment screw (S). Rotating the screw clockwise will increase the ratio. Rotating the screw counterclockwise will decrease the ratio. The indicator pin (V) will move along the ratio indicator scale (U) as the ratio adjustment screw is rotated. When the pin is above the desired ratio, remove the wrench and perform a ratio test as described on page 12.

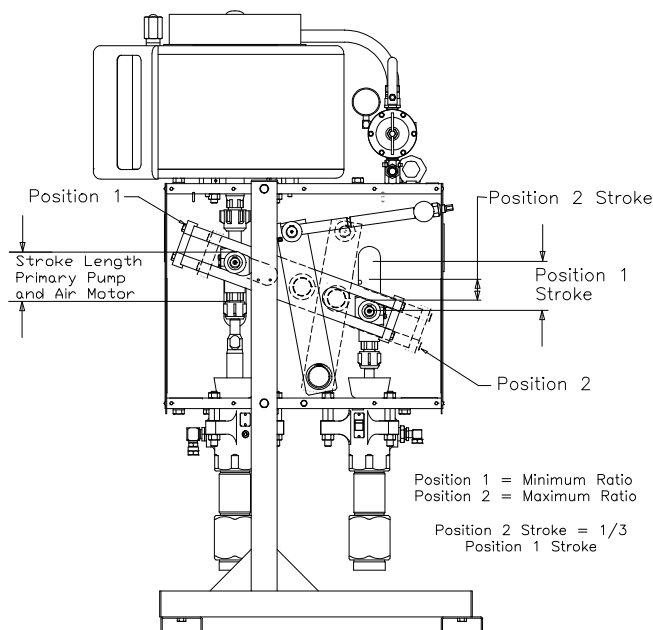

Fig. 5

Operation

WARNING



INJECTION HAZARD

The system pressure must be manually relieved to prevent the system from starting or spraying accidentally. Fluid under high pressure can be injected through the skin and cause serious injury. To reduce the risk of an injury from injection. To reduce the risk of parts, follow the **Pressure Relief Procedure** whenever you:

- are instructed to relieve the pressure,
- stop spraying,
- check or service any of the system equipment,
- or install or clean the spray tips.

Pressure Relief Procedure

1. Lock the spray gun's trigger safety.
2. Shut off **ALL** fluid supplies to the pump.
3. Close the bleed-type master air valve.
4. Unlock the spray gun's trigger safety.
5. Hold a metal part of the spray gun firmly to the side of a grounded metal pail. Trigger the spray gun into the pail to relieve pressure.
6. Lock the spray gun's trigger safety.
7. Open the sampling valves, having a container ready to catch the drainage.
8. If you suspect that the spray tip or nozzle or the hose is completely clogged or that pressure has not been fully relieved after following the steps above, follow this procedure: Very slowly loosen the tip guard retaining nut or hose end coupling and relieve pressure gradually, then loosen completely. Now clear the obstruction.

System Flushing

The pumps were tested with lightweight oil at the factory. Before operating the pump, thoroughly flush the Hydra-Cat H.P. to prevent contamination of your fluids.

NOTE:

Flush the mixer, hose and gun often enough to prevent fluid from reacting or curing in them. Contact your fluid manufacturer for the effective pot life of the fluid you are using.

1. Put the pump intake hoses into a 5 gallon (20 liter) container of a compatible solvent. Refer to the fluid manufacturer's recommendations.
2. Start the pump as explained below.
3. Do not install a spray tip yet. Hold a metal part of the gun firmly to the side of a grounded metal pail. Using the lowest possible air pressure to the air motor that will activate the pump, trigger the gun into the pail.
4. When clean solvent comes from the spray gun, release the trigger and carefully check all connections in the system for leaks.
5. Take the hoses out of the solvent, and trigger the gun until all the solvent has been pumped out of the hoses. Immediately turn off the bleeder-type master air valve.

Start the Pump

1. Close the bleed-type master air valve, and turn the air regulator knob all the way out (counterclockwise).
2. Turn on the main air supply.
3. With the mixer manifold handle in the open position, trigger the gun, slowly open the bleed-type master air valve, and turn the air regulator knob clockwise until the pump starts.
4. Allow the pump to cycle slowly until all the air is pushed out of the lines. Release the trigger. The pump will stall against the pressure.
5. The manifold handle controls fluid flow. With the lever of the manifold in the open (down) position, base and catalyst are supplied to the gun. To stop the flow, move the handle to the closed (up) position.

Standard Operating Flushing

Use the solvent valves to flush contaminants and mixed fluids from the mixer manifold, hose and spray gun. Follow the procedure provided with the mix manifold assembly.

Checking the Ratio

Note: The mix ratio must be checked at the normal operating fluid pressure of the pump. Most mixer manifolds provide a means for checking mix ratio that includes needle valves for adjusting the fluid pressure during the test. The following procedure is an example of how to properly check the mix ratio.

1. Open the mixer manifold and trigger your spray gun.
2. Set your operating pressure. After determining the operating pressure, release the spray gun trigger and engage the safety latch.
3. Close the mixer manifold inlet valves.
4. Slightly open the sampling valve on the secondary pump side. Slightly open the sampling valve on the primary pump side. This will prevent pressure from building up on the secondary pump, causing the relief valve to open.
5. Place a grounded waste container under the sampling valve.

6. Open the mixer manifold. Use the sampling valves to adjust the pressures to your **normal operating pressures**.
7. Close the mixer manifold. Put the sampling containers under the sampling valves.
8. Open the mixer manifold. Check the ratio; make sure the pressure is within 20% of your normal operating pressure. Close the mixer manifold when enough fluid has been dispensed into the sampling containers.

NOTE: If the pressure readings are not within 20% of your normal operating pressure, follow the flushing procedure on page 11, then take a sample again. If your sample ratio is incorrect, there is a problem with the sampling valves, ratio setting, or pump operation. Check the ratio setting or service the sampling valves or pump.

Maintenance

Pump Lubrication

Wet Cups

Each of the fluid cylinders has a wet cup (18) at the top that must be kept lubricated. See figure 6. The wet cups should be inspected and filled on a weekly basis, or more frequently if found to be dry. To inspect the wet cups, follow the pressure relief procedure on page 11.

WARNING

To reduce the risk of serious injury whenever you are instructed to relieve pressure, always follow the **Pressure Relief Procedure** on page 11.

With the bleeder type main air valve (1) turned off, remove the thumb screws (14) and the two guards (15) from the sides of the proportioner. The wet cups (18) should be filled to 1/3 full with Graco Throat Seal Liquid (TSL) or compatible solvent.

The packing nuts (19) are torqued at the factory and are ready for operation. If one becomes loose and there is leaking from the throat packings, **relieve the pressure**, then torque the nut to 136–149 N.m (100–110 ft-lb) using the supplied wrench (20). Do this whenever necessary. Do not over tighten the packing nut.

Bearings

Many of the bearing surfaces on the proportioner are permanently lubricated or are self lubricating. There are four main bearings (21) on the lever arm **that must be lubricated** on a regular interval. The lubrication interval is every six months in single shift operation. To lubricate the bearings, follow the pressure relief procedure on page 11.

WARNING

To reduce the risk of serious injury whenever you are instructed to relieve pressure, always follow the **Pressure Relief Procedure** on page 11.

With the bleeder type main air valve turned off, remove the twenty hex bolts (16) with a 13mm wrench or socket and then remove the four sheet metal covers (17) from the front and back of the proportioner.

The left rear cover may contain a sensor attached to a cable. Do not remove the sensor, but carefully set the cover to the side without straining or damaging the sensor or cable. The four main bearings (21) are now exposed. Use the adapter (205-532) provided to grease all four bearings. One or two squirts (2-3 cc) will be sufficient.

Air Lubrication

Make sure to use an Industrial Grade 1, Heavy Duty, Extreme Pressure, Lithium Soap Grease, Graco Part Number 110-293 or equivalent.

If your air supply is very dry, install an air line lubricator between the air regulator and the pump air motor for automatic lubrication. Refer to the air motor manual for details.

Replace the covers (17) and the bolts (16) after greasing, and before starting the machine. The covers (17) are safety guards and must be in place when the proportioner is in operation.

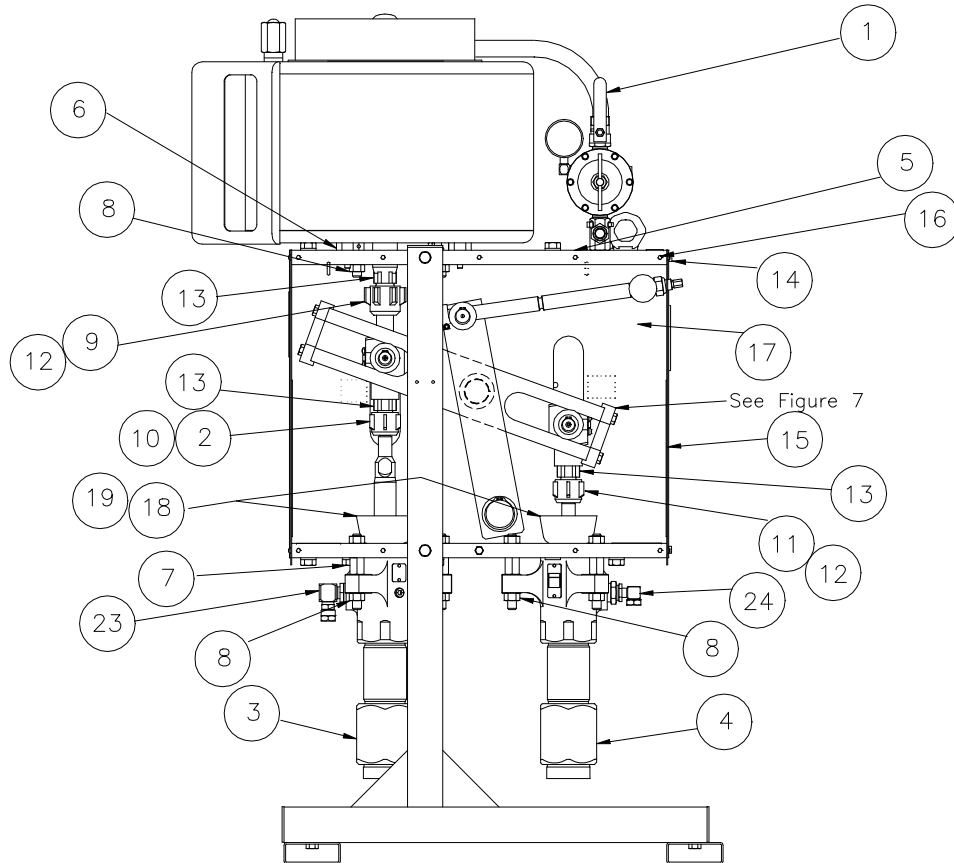

KEY

- | | |
|----------------------------------|----------------------------|
| 1 BLEEDER TYPE MAIN AIR VALVE | 13 ROD ADAPTER |
| 2 AIR MOTOR | 14 THUMB SCREWS |
| 3 PRIMARY CYLINDER | 15 GUARDS |
| 4 SECONDARY CYLINDER | 16 HEX BOLTS |
| 5 FRAME | 17 COVERS |
| 6 AIR MOTOR TIE RODS | 18 WET CUPS |
| 7 FLUID CYLINDER TIE RODS | 19 PACKING NUTS |
| 8 TIE ROD NUTS | 20 PACKING NUT WRENCH |
| 9 CONNECTING ROD NUT, AIR MOTOR | 21 MAIN BEARINGS |
| 10 CONNECTING ROD NUT, PRIMARY | 22 SNAP RING |
| 11 CONNECTING ROD NUT, SECONDARY | 23 FLUID OUTLET, PRIMARY |
| 12 COUPLING COLLARS | 24 FLUID OUTLET, SECONDARY |

Fig. 6

Troubleshooting

Troubleshooting Techniques

Because the pumps are mechanically linked, the action of one pump can affect the readings of the second pump. Therefore, the key to successful troubleshooting is to **be sure to isolate the problem**.

For example, if the secondary pump pressure, as read on the gauge, is low and sluggish during the pump changeover. The most likely problem is a binding primary pump. To isolate the problem:

1. Relieve the pressure.
2. With the sampling valves still open, set the air supply regulator to the lowest setting and open the bleed-type main air valve (1). Refer to figure 6. Increase the regulator setting until the pump just begins to move. Notice the position of the secondary pump (11). Turn off the bleeder-type main air valve (1) so that the secondary pump rod is at its lowest position when the pump stops.

WARNING

To reduce the risk of a serious injury, always follow the **Pressure Relief Procedure** on page 11 whenever you are instructed to relieve the pressure.

3. With the main bleed-type air valve (1) off, remove the thumb screws (14) and guards (15) from each side of the proportioner.
4. Unscrew the connecting rod nut (11) from the secondary pump. Now you can verify the operation of the primary pump alone.

Reinstall the guards (15) on both sides of the proportioner. Turn the main air valve (1) back on and carefully increase the air pressure.

5. Using the sampling valves at the mixer manifold:
 - A. Open and close the sampling valves and check for pump stalling on both the up and down strokes.
 - B. Check for rapid gauge response during the pump changeover
6. When the operation of the primary side has been verified, reconnect the connecting rod (11) of the secondary.
7. With the sampling valves still open, set the air supply regulator to the lowest setting and open the bleed-type main air valve (1). Increase the regulator setting until the pump just begins to move. Notice the position of the primary pump. Turn off the bleeder-type main air valve (1) so that the primary pump rod (10) is at its lowest position when the pump stops.

8. With the main bleed-type air valve (1) off, remove the thumb screws (14) and guards (15) from each side of the proportioner.
9. Unscrew the connecting rod nut (10) from the primary pump. Now you can verify the operation of the secondary pump alone.

Reinstall the guards (15) on both sides of the proportioner. Turn the main air valve (1) back on and carefully increase the air pressure.

10. Using the sampling valves at the mixer manifold:
 - A. Open and close the sampling valves and check for pump stalling on both the up and down strokes.
 - B. Check for rapid gauge response during the pump changeover
11. When the operation of the secondary side has been verified, reconnect the connecting rod (10) of the primary pump.

WARNING

Use very low air pressure to the air motor when troubleshooting the system. This system can produce very high fluid pressure, which can cause serious injury, including injection, splashing in the eyes or on the skin, and injury from moving parts.

To reduce the risk of a serious injury, always follow the **Pressure Relief Procedure** on page 11 if the problem you are checking does not require air.

WARNING

To reduce the risk of injuring or amputating your hands, fingers, or other body parts, never place your hands, body or tools inside the safety panels for any reason while the unit is operating.

Troubleshooting Chart

PROBLEM	CAUSE	SOLUTION
System will not run or stops while running.	Air pressure or air volume is too low.	Increase air pressure. Check air compressor and air supply filters regulator, lubricator valves and other components for blockages and restrictions. If this is a new system, be sure that air supply components have been sized properly.
	The fluid valves or hoses are closed or restricted.	Check the gun, fluid hoses, mix manifold, static mixer, fluid filters, regulators, valves and other fluid line components for blockages and restrictions. If this is a new system, be sure that the fluid components have been sized properly.
	The air motor is worn or damaged.	Service the air motor. See "servicing the Air Motor" on page 17.
	The displacement cylinder(s) is damaged or has seized	See troubleshooting techniques below to isolate the problem cylinder. See "Service the cylinders" on page 16.
The fluid pressure bounces significantly (>500 psi) while pump is running	Air volume is too low.	Verify that air pressure at the air motor inlet is not dropping during pump changeover. Check air compressor and air supply filters regulator, lubricator valves and other components for blockages and restrictions. If this is a new system, be sure that air supply components have been sized properly. 1" NPT hoses, fittings and accessories are required to provide the necessary air volume.
	Feed pump pressure is too high.	Reduce feed pump pressure. Feed pump pressures must be less than 25% of proportioner output pressure.
	The displacement cylinder(s) check valves are not seating.	See troubleshooting techniques below to isolate the problem cylinder. See "Service the cylinders" on page 16.
Mix ratio test is significantly different from the mix ratio setting.	Mix ratio test was not performed at the normal operating pressure of the pump	Perform ratio test again following ratio test procedure on page 12.
	Running out of one material.	Check and refill material reservoirs. Repeat the test after the air has been removed from the system.
	The displacement cylinder(s) are worn or the check valves are not seating.	See troubleshooting techniques below to isolate the problem cylinder(s). See "Service the cylinders" on page 16.
Spray output is spitting	Running out of one material.	Check and refill material reservoirs. Remember that once air is in the fluid system it may take a while for all of it to escape..
	Siphon hoses are leaking in air.	Tighten and seal all siphon fittings on proportioning pump and feed pumps.
A squeaking or knocking noise is heard.	The bearings are dry or worn.	Lubricate the bearings or replace them if required. See "service the bearings" on page 18.
The proportioner speeds up or runs erratically	Running out of one material.	Check and refill material reservoirs.
	The cylinders are worn or damaged.	See troubleshooting techniques below to isolate the problem cylinder(s). See "Service the cylinders" on page 16.

Service

Required Tools

- Set of large adjustable wrenches
- Set of metric sockets or wrenches
- Large pipe wrench
- Torque wrench
- Rubber mallet
- Flat end punch

WARNING

To reduce the risk of serious injury or amputation, carefully follow all instructions listed below. In addition, be sure that the pressure relief procedure has been completed and that the main bleeder-type air valve has been turned off and locked out before removing ANY guards or covers from the proportioner.

Disconnecting the Displacement Pump(s)

1. Flush the System. Follow the procedure on page 11.
2. Relieve the pressure.

WARNING

To reduce the risk of serious injury whenever you are instructed to relieve pressure, always follow the **Pressure Relief Procedure** on page 11.

3. Disconnect the siphon hose and the fluid outlet hose.

4. With the bleeder type main air valve turned off (1), remove the thumb screws (14) and the two guards (15) from the sides of the proportioner.
5. Disconnect the displacement pump (3) from the frame (5) as follows:
6. Note the relative position of the pump's fluid outlet (23) to the frame and also note the frame location of displacement pump being removed. Each displacement pump must be returned to its original position and orientation.

CAUTION

Be sure to use two people when lifting, moving, or disconnecting the pump. This pump is too heavy for one person. Be sure to support the displacement pump while it is being disconnected, to prevent it from falling and causing injury or property damage. Do this by securely bracing the pump, or by having at least two people hold it while another disconnects it.

7. Using an adjustable wrench (or hammer and punch), unscrew the coupling nut (10,11) from the rod adapter (13). Do not lose or drop the coupling collars (12). See Fig. 6.
8. Hold the tie rod flats with a wrench to keep the rods from turning. Unscrew the nuts (8) from the tie rods (7). Carefully remove the displacement pump (3) from the frame.
9. Refer to the separate manual supplied for displacement pump service. Some models use two different displacement pumps. Be sure to look at the model number and use the appropriate manual for service and reference.

Reconnecting the Displacement Pump

1. Make sure the coupling nut (10,11) and the coupling collars (12) are in place on the displacement rod. See Fig. 6.
2. Use at least two people to hold the displacement pump while another reconnects it to the frame (see the **CAUTION** in the removal procedure above).
3. Position and orient the displacement pump (3,4) to the frame (5) as was noted in step 6 under Disconnecting the Displacement Pump.
4. Position the displacement pump (3,4) on the tie rods (7).
5. Screw the nuts (8) onto the tie rods (7) and torque to 81–89 N.m (60–66 ft-lb).
6. Screw the coupling nut (10) onto the rod adapter (13) loosely. Hold the rod adapter flats with a wrench to keep it from turning. Use an adjustable wrench to tighten the coupling nut. Torque to 196–210 N.m ft-lb).
7. Fill the wet cup (18) 1/3 full with Graco Throat Seal Lubricant or compatible solvent.
8. Reconnect all hoses.
9. Replace the two guards (15) and the thumb screws (14) from the sides of the proportioner.
10. Turn on the air supply. Follow the procedure for starting the pump on page 11. Run the pump slowly at first to ensure proper operation.

WARNING

To reduce the risk of serious injury whenever you are instructed to relieve pressure, always follow the **Pressure Relief Procedure** on page 11.

11. Before returning the pump to production, relieve the pressure and re-torque the packing nut (2) to 136–149 N.m (100–110 ft-lb). This must be performed after the pump has been cycled a number of times.

Disconnecting the Air Motor

1. Relieve the pressure.

WARNING

To reduce the risk of serious injury whenever you are instructed to relieve pressure, always follow the **Pressure Relief Procedure** on page 11.

2. With the bleeder type main air valve turned off, disconnect the air hose from the air motor.
3. Remove the thumb screws (14) and the two guards (15) from the sides of the proportioner.
4. Disconnect the air motor (2) from the frame (5) as follows:

CAUTION

Be sure to use an overhead hoist when lifting, moving or disconnecting the air motor. This air motor weighs 145 lbs. and is too heavy for one person to handle. A lift ring is provided on the motor for this purpose.

5. Note the relative position of the air motor's air connection to the frame. The air motor must be returned to its original orientation.
6. Using an adjustable wrench (or hammer and punch), unscrew the coupling nut (9) from the rod adapter (13). Do not lose or drop the coupling collars (12). See Fig. 6.
7. Hold the tie rod flats with a wrench to keep the rods from turning. Unscrew the nuts (8) from the tie rods (6). Carefully remove the air motor (2) from the frame.
8. Refer to the separate manual supplied for air motor service. Be sure to look at the model number stamped on the air motor and use the appropriate manual for service and reference.

Reconnecting the Air Motor

1. If the connecting rod has been removed from the Air Motor Stud as a part of servicing, be sure to use thread adhesive when reinstalling the connecting rod on to the Air Motor Stud.
2. Make sure the coupling nut (9) and the coupling collars (12) are in place on the rod adapter (13).
3. Use an overhead hoist to position the air motor on the frame in the same orientation as noted in step 5 of disconnecting the air motor. (see the **CAUTION** in the removal procedure above).
4. Position the air motor (2) on the tie rods (6).
5. Screw the nuts (8) onto the tie rods (6) and torque to 81–89 N.m (60–66 ft-lb).
6. Screw the coupling nut (9) onto the rod adapter (13) loosely. Hold the rod adapter flats with a wrench to keep it from turning. Use an adjustable wrench to tighten the coupling nut. Torque to 196–210 N.m ft-lb).
7. Reconnect the air hose
8. Replace the two guards (15) and the thumb screws (14) onto the sides of the proportioner.
9. Turn on the air supply. Follow the procedure for starting the pump on page 11. Run the pump slowly at first to ensure proper operation

Replacing the Bearings

1. Relieve the Pressure. Refer to Figure 6 and Figure 7.

WARNING

To reduce the risk of serious injury whenever you are instructed to relieve pressure, always follow the **Pressure Relief Procedure** on page 11.

2. With the bleeder type main air valve (1) turned off, remove the twenty hex bolts (16) with a 13mm wrench or socket and then remove the four sheet metal covers (17) from the front and back of the proportioner. The left rear cover may contain a sensor attached to a cable. Do not remove the sensor, but carefully set the cover to the side without straining or damaging the sensor or cable. The (4) four main bearings (21) are now exposed.
3. Remove the thumb screws (14) and the two guards (15) from the sides of the proportioner.
4. Using an adjustable wrench (or hammer and punch), unscrew the coupling nuts (10, 11, 12) from each of the rod adapters (13) on the two displacement pumps and the air motor. Do not lose or drop the coupling collars (12). See Fig. 6.
5. The left rear bearing shaft has a magnet stuck on its end. Remove the magnet and put it in a safe place. Use a snap ring pliers to remove the four snap rings (22) from the shafts and remove the retaining washers.
6. You should now be able to slide the bearings (21) off of the shaft ends.
7. Replace the bearings only with identical Graco replacement parts. Pack the bearings in Industrial Grade 1, Heavy Duty, Extreme Pressure, Lithium Soap Grease, Graco Part Number 110-293 or equivalent.
8. Re-install the new bearings (21) onto the shafts. Doing so may require slightly shifting the shaft assembly which may have dropped during bearing removal.
9. Re-install the four retaining washers and their snap rings (22).
10. Replace the magnet onto the end of the left rear bearing shaft.
11. Make sure the coupling nuts (10, 11, 12) and the coupling collars (12) are in place on all three rod adapters.
12. Screw all three (3) coupling nuts (10, 11, 12) onto the rod adapters (13) loosely. Hold each rod adapters flats with a wrench to keep it from turning. Use an adjustable wrench to tighten the coupling nuts. Torque to 196–210 N.m ft-lb).
13. Replace the covers (17) and the bolts (16).
14. Replace the two guards (15) and the thumb screws (14) onto the sides of the proportioner.
15. Turn on the air supply. Follow the procedure for starting the pump on page (11). Run the pump slowly at first to ensure proper operation.

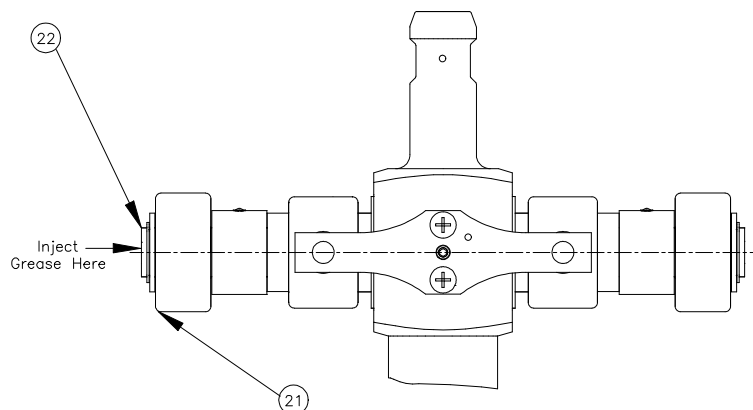
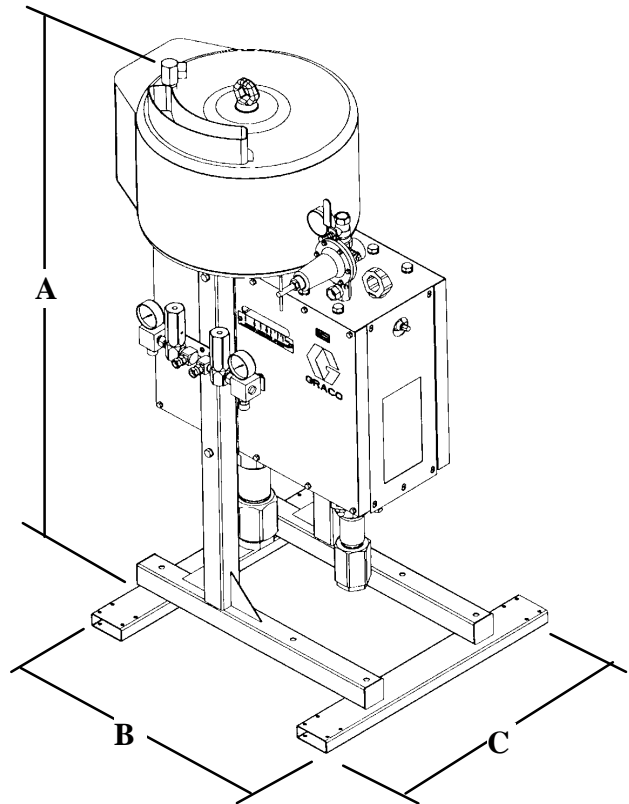

Fig. 7

Bearing Inset

Dimensions

- (A) Height..... 66.0 inch 1676 mm)
- (B) Length 31.5 inch (800 mm)
- (C) Width..... 33.0 inch (838 mm)
- (D) Air Inlet..... 3/4 npt(f)
- (E) Fluid Inlets Two, 2" npt(f)
- (G) Fluid Outlet Two 1/2" npt(f)
- (H) Relief Valve Outlets Two, 1/4 npt(m)
- Net Weight 700 pounds (320 kg)



Premier Air Consumption						
At 40 PSI (2.8 bar)		At 70 PSI (4.9 bar)		At 100 PSI (7.0 bar)		At cycles per min
CFM	M ³ /min	CFM	M ³ /min	CFM	M ³ /min	
13	0.36	20	0.56	26	0.74	5
25	0.71	40	1.13	52	1.48	10
38	1.07	60	1.69	78	2.22	15
50	1.42	80	2.26	104	2.95	20
63	1.78	100	2.82	130	3.69	25
75	2.13	120	3.39	156	4.43	30
88	2.49	140	3.95	183	5.17	35
100	2.84	160	4.52	209	5.91	40

King Air Consumption						
At 40 PSI (2.8 bar)		At 70 PSI (4.9 bar)		At 100 PSI (7.0 bar)		At cycles per min
CFM	M ³ /min	CFM	M ³ /min	CFM	M ³ /min	
8	0.23	13	0.36	15	0.43	5
16	0.45	25	0.72	31	0.87	10
24	0.68	38	1.07	46	1.30	15
32	0.90	51	1.43	61	1.74	20
40	1.13	63	1.79	77	2.17	25
48	1.35	76	2.15	92	2.61	30
56	1.58	88	2.51	107	3.04	35
64	1.80	101	2.86	123	3.48	40

NOTES

Technical Data

Air motor effective diameter..... Premier 12.64" (321 mm)
..... King 10.00" (254 mm)
Air motor stroke 4.75" (120 mm)
Operating air pressure range.....20 to 100 psi (1.4 to 7 bar) Premier
20 to 90 psi (1.4 to 6.2 bar) King
Recommended pump speed40 cycles per minute maximum
Maximum fluid inlet pressure.....25% of Output or 1000 psi max.
Maximum pump operating temperature 180°F (82°C)

Wetted parts:

Carbon Steel Models

Primary and secondary displacement pumps.....Carbon Steel; Chrome Steel; Alloy Steel;
Chrome, Zinc, and Nickel Plating; 550 and 17-4 PH Grades of Stainless Steel;
Ductile Iron; Tungsten Carbide; PTFE; Glass-Filled PTFE ; Leather

Stainless Steel Models

Primary and secondary displacement pumps.....316, 440 and 17-4 PH Grades of Stainless Steel;
Tungsten Carbide; PTFE Glass-Filled PTFE ;Leather

All Models

Fluid hoses Nylon, Zinc-plated steel couplings
Pressure relief valves304 Stainless Steel, Graphite-filled PTFE
Tungsten carbide (Nickel binder)

Premier Noise level at 90 psi (6.3 bar) inlet air and at 40 cpm maximum load.....86 dB(A)

King Noise level at 90 psi (6.3 bar) inlet air and 15 cpm maximum load 90.5 dB(A) Pressure
97.7 dB(A) Power

The Graco Warranty and Disclaimers

WARRANTY

Graco warrants all equipment manufactured by it and bearing its name to be free from defects in material and workmanship on the date of sale by an authorized Graco distributor to the original purchaser for use. As purchaser's sole remedy for breach of this warranty, Graco will, for a period of twelve months or two thousand hours of operation from time of sale, repair or replace any part of the equipment proven defective. This warranty applies only when the equipment is installed, operated and maintained in accordance with Graco's written recommendations.

This warranty does not cover, and Graco shall not be liable for, any malfunction, damage or wear caused by faulty installation, misapplication, abrasion, corrosion, inadequate or improper maintenance, negligence, accident, tampering, or substitution of non-Graco component parts. Nor shall Graco be liable for malfunction, damage or wear caused by the incompatibility with Graco equipment of structures, accessories, equipment or materials not supplied by Graco, or the improper design, manufacture, installation, operation or maintenance of structures, accessories, equipment or materials not supplied by Graco.

This warranty is conditioned upon the prepaid return of the equipment claimed to be defective to an authorized Graco distributor for verification of the claim. If the claimed defect is verified, Graco will repair or replace free of charge any defective parts. The equipment will be returned to the original purchaser transportation prepaid. If inspection of the equipment does not disclose any defect in material or workmanship, repairs will be made at a reasonable charge, which charges may include the costs of parts, labor and transportation.

DISCLAIMERS AND LIMITATIONS

The terms of this warranty constitute purchaser's sole and exclusive remedy and are in lieu of any other warranties (express or implied), **including warranty of merchantability or warranty of fitness for a particular purpose**, and of any non-contractual liabilities, including production liabilities, based on negligence or strict liability. Every form of liability for direct, special or consequential damages or loss is expressly excluded and denied. In no case shall Graco's liability exceed the amount of the purchase price. Any action for breach of warranty must be brought within two (2) years of the date of sale.

EQUIPMENT NOT COVERED BY GRACO WARRANTY

Graco makes no warranty, and disclaims all implied **warranties of merchantability and fitness for a particular purpose**, with respect to accessories, equipment, materials, or components sold but not manufactured by Graco. These items sold, but not manufactured by Graco (such as electric motor, switches, hose, etc.) are subject to the warranty, if any, of their manufacturer. Graco will provide purchaser with reasonable assistance in making any claim for breach of these warranties.

Graco Phone Number

FOR TECHNICAL ASSISTANCE, contact your Graco distributor or call Graco Technical Assistance at (612) 379-3622.

Sales Offices: Detroit, Los Angeles

Foreign Offices: Canada; England; Switzerland; France; Germany; Hong Kong; Japan; Korea

GRACO INC. P.O. BOX 1441 MINNEAPOLIS, MN 55440-1441

PRINTED IN U.S.A. 684-028 Revised 1/97