

# INSTRUCTIONS-PARTS LIST



306-726

Rev F  
Supersedes D  
and PCN F

This manual contains IMPORTANT  
WARNINGS AND INSTRUCTIONS  
READ AND RETAIN FOR REFERENCE

For Non-Abrasive Fluids

## 10:1 RATIO PRESIDENT® PUMP

1800 psi (124 bar) MAXIMUM WORKING PRESSURE

### Model 205-626, Series H

\*Wall mount, stubby pump

### Model 205-627, Series G

Pail length, for 5 or 10 gallons,  
with Relax-A-Valve. UL Listed.

### Model 205-628, Series H

Drum length for open-head drum,  
with Relax-A-Valve

### Model 222-065, Series A

Drum length for closed-head drum

### Model 222-095, Series A

Drum length for closed-head drum,  
with bung adapter

- \* Two lengths of extension tubes are available for this pump to convert it to a drum or tank length. See ACCESSORIES, page 17.

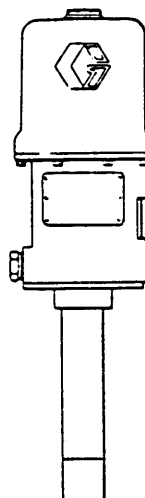

MODEL 205-626  
SHOWN

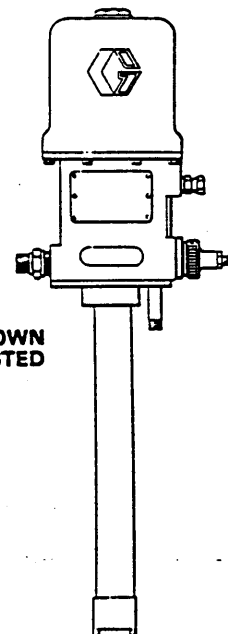

MODEL 205-627 SHOWN  
U.L. LISTED

### INDEX

Warnings .....	2, 3
Installation .....	4, 5
Operation .....	5
Maintenance .....	6
Troubleshooting .....	7
Displacement Pump Repair .....	8
Check Valve Adjustment .....	9
Relax-A-Valve Repair .....	9
Parts Lists and Drawings	
Model 222-065 .....	10
Model 222-095 .....	11
Model 205-626 .....	12
Model 205-628 .....	13
Model 205-627 .....	13
Relax-A-Valve .....	14
How to Order Replacement Parts .....	14
Dimensions .....	15, 16
Accessories .....	17
Technical Data .....	Back Cover
Warranty .....	Back Cover

### WARNING

**Hazard of Using Fluids Containing Halogenated Hydrocarbons**  
Never use 1,1,1-trichloroethane, methylene chloride, other halogenated hydrocarbon solvents or fluids containing such solvents in this equipment. Such use could result in a serious chemical reaction, with the possibility of explosion, which could cause death, serious bodily injury and/or substantial property damage.

Consult your fluid suppliers to ensure that the fluids being used are compatible with aluminum and zinc parts

# WARNING

HIGH PRESSURE SPRAY CAN CAUSE SERIOUS INJURY. FOR PROFESSIONAL USE ONLY. OBSERVE ALL WARNINGS. Read and understand all instruction manuals before operating equipment.

## FLUID INJECTION HAZARD

### General Safety

This equipment generates very high fluid pressure. Spray from the gun/valve, leaks or ruptured components can inject fluid through your skin and into your body and cause extremely serious bodily injury, including the need for amputation. Also, fluid injected or splashed into the eyes can cause serious damage.

NEVER point the gun/valve at anyone or at any part of the body. NEVER put hand or fingers over the spray tip. ALWAYS have tip guard in place on gun/valve when spraying.

ALWAYS follow the **Pressure Relief Procedure**, right, before cleaning or removing the spray tip or nozzle or servicing any system equipment.

NEVER try to "blow back" paint; this is not an air spray pump.

NEVER try to stop or deflect leaks with your hand or body.

Be sure equipment safety devices are operating properly before each use.

### Medical Treatment

If any fluid appears to penetrate your skin, get **EMERGENCY MEDICAL CARE AT ONCE. DO NOT TREAT AS A SIMPLE CUT.** Tell the doctor exactly what fluid was injected.

*Note to Physician: Injection in the skin is a traumatic injury. It is important to treat the injury surgically as soon as possible. Do not delay treatment to research toxicity. Toxicity is a concern with some exotic coatings injected directly into the blood stream. Consultation with a plastic surgeon or reconstructive hand surgeon may be advisable.*

### Spray Gun and Dispensing Valve Safety Devices

Be sure all gun/valve safety devices are operating properly before each use. Do not remove or modify any part of the gun/valve; this can cause a malfunction and result in serious bodily injury.

### Safety Latch (if applicable)

Whenever you stop spraying, even for a moment, always set the gun/valve safety latch in the closed or "safe" position, making the gun/valve inoperative. Failure to set the safety latch can result in accidental triggering of the gun/valve.

### Diffuser (if applicable)

The gun diffuser breaks up spray and reduces the risk of fluid injection when the tip is not installed. Check diffuser operation regularly. Follow the **Pressure Relief Procedure**, below, then remove the spray tip. Aim the gun into a metal pail, holding the gun firmly to the pail. Using the lowest possible pressure, trigger the gun. If the fluid emitted is *not* diffused into an irregular stream, replace the diffuser immediately.

## EQUIPMENT MISUSE HAZARD

### General Safety

Any misuse of the spray equipment or accessories, such as overpressurizing, modifying parts, using incompatible chemicals and fluids, or using worn or damaged parts, can cause them to rupture and result in fluid injection or other serious bodily injury, fire, explosion or property damage.

NEVER alter or modify any part of this equipment; doing so could cause it to malfunction.

CHECK all spray equipment regularly and repair or replace worn or damaged parts immediately.

ALWAYS read and follow the fluid and solvent manufacturer's recommendations regarding the use of protective clothing and equipment.

### Tip Guard

ALWAYS have the tip guard in place on the gun/valve while spraying. The tip guard alerts you to the fluid injection hazard and helps reduce, but does not prevent, accidentally placing your fingers or any part of your body close to the spray tip.

### Trigger Guard (if applicable)

Never operate the gun with the trigger guard removed. This guard helps prevent the gun from triggering accidentally if it is dropped or bumped.

### Spray Tip and Nozzle Safety

Use extreme caution when cleaning or changing spray tips or nozzles. If the spray tip or nozzle clogs while spraying, engage the gun/valve safety latch immediately. ALWAYS follow the **Pressure Relief Procedure** and then remove the spray tip or nozzle to clean it.

NEVER wipe off build-up around the spray tip or nozzle until pressure is fully relieved and the gun/valve safety latch is engaged.

### Pressure Relief Procedure

To reduce the risk of serious bodily injury, including fluid injection or splashing in the eyes or on the skin, always follow this procedure whenever you shut off the pump, when checking or servicing any part of the system, when installing or changing spray tips, and whenever you stop spraying.

1. Engage the spray gun or dispensing valve safety latch.
2. Close the pump air regulator.
3. Close the master bleed-type air valve (required).
4. Disengage the gun or dispensing valve safety latch.
5. Hold a metal part of gun/valve firmly to a grounded metal waste container and trigger to relieve fluid pressure.
6. Engage the safety latch again.
7. Open the pump drain valve (required in your system), having a container ready to catch the drainage.

**NOTE:** If your pump has a Relax-A-Valve set in the automatic position, Step 7 is not necessary.

8. Leave the drain valve open until you are ready to spray again.

*If you suspect that the spray tip or hose is clogged or that fluid pressure is not fully relieved after following the steps above, VERY SLOWLY loosen the tip guard or hose end coupling and allow pressure to be relieved gradually, then remove completely. Now clear the tip or hose obstruction.*

### System Pressure

This 10:1 Ratio President Pump develops 1800 psi (124 bar) **MAXIMUM WORKING PRESSURE** at 180 psi (12.4 bar) air pressure. Never exceed 180 psi (12.4 bar) air supply to the motor. NEVER exceed the stated maximum working pressure of the pump or of the lowest rated component in your system.

Be sure that all accessories you add to the spray system are properly rated to withstand the maximum air and fluid working pressures of this system.

### Fluid Compatibility

BE SURE that all fluid and solvent used are chemically compatible with the wetted parts shown in the Technical Data on the back cover. Always read the fluid and solvent manufacturer's literature before using them in this sprayer.

## FIRE OR EXPLOSION HAZARD

Static electricity is created by the high velocity flow of fluid through the pump and hose. If every part of the spray equipment is not properly grounded, sparking may occur, and the system may become hazardous. Sparking may also occur when plugging in or unplugging a power supply cord. Sparks can ignite fumes from solvents and the fluid being sprayed, dust particles and other flammable substances, whether you are spraying indoors or outdoors, and can cause a fire or explosion and serious bodily injury and property damage. Do not plug in or unplug any power supply cords in the spray area when there is any chance of igniting fumes still in the air.

If you experience any static sparking or even a slight shock while using this equipment, STOP SPRAYING IMMEDIATELY. Check the entire system for proper grounding. Do not use the system again until the problem has been identified and corrected.

### Grounding

To reduce the risk of static sparking, ground the pump and all other spray equipment used or located in the spray area. CHECK your local electrical code for detailed grounding instructions for your area and type of equipment. BE SURE to ground all of this spray equipment:

1. *Pump*: use a ground wire and clamp as shown in Fig 1.
2. *Air hoses*: use only grounded air hoses.
3. *Fluid hoses*: use only grounded fluid hoses.
4. *Air compressor*: follow manufacturer's recommendations.
5. *Spray gun or dispensing valve*: grounding is obtained through connection to a properly grounded fluid hose and pump.
6. *Fluid supply container*: according to local code.
7. *Object being sprayed*: according to your local code.
8. *All solvent pails* used when flushing, according to local code. Use only metal pails, which are conductive, placed on a grounded surface. Do not place the pail on a non-conductive surface, such as paper or cardboard, which interrupts the grounding continuity.
9. *To maintain grounding continuity when flushing or relieving pressure*, always hold a metal part of the gun/valve firmly to the side of a grounded metal pail, then trigger the gun/valve.

## HOSE SAFETY

High pressure fluid in the hoses can be very dangerous. If the hose develops a leak, split or rupture due to any kind of wear, damage or misuse, the high pressure spray emitted from it can cause a fluid injection injury or other serious bodily injury or property damage.

**ALL FLUID SPRAY HOSES MUST HAVE SPRING GUARDS ON BOTH ENDS!** The spring guards help protect the hose from kinks or bends at or close to the coupling which can result in hose rupture.

**TIGHTEN** all fluid connections securely before each use. High pressure fluid can dislodge a loose coupling or allow high pressure spray to be emitted from the coupling.

**NEVER** use a damaged hose. Before each use, check entire hose for cuts, leaks, abrasion, bulging cover, or damage or movement of the hose couplings. If any of these conditions exist, replace the hose immediately. **DO NOT** try to recouple high pressure hose or mend it with tape or any other device. A repaired hose cannot contain the high pressure fluid.

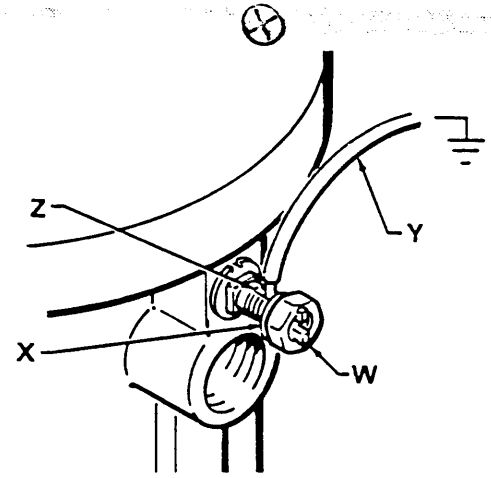

Fig 1

To ground the pump, loosen the grounding lug locknut (W) and washer (X). Insert one end of a 12 ga. (1.5 mm<sup>2</sup>) minimum ground wire (Y) into the slot in lug (Z) and tighten locknut securely. See Fig. 1. Connect the other end of the wire to a true earth ground. Refer to page 17 to order a ground wire and clamp.

### Flushing Safety

To reduce the risk of injection injury, static sparking, or splashing follow the **Pressure Relief Procedure** on page 2, and *remove the spray tip (spray guns or spray valves only) before flushing*. Hold a metal part of the gun/valve firmly to the side of a grounded metal pail and use the lowest possible fluid pressure during flushing.

## MOVING PARTS HAZARD

The piston in the air motor, located behind the air motor plates, moves when air is supplied to the motor. Moving parts can pinch or amputate your fingers or other body parts. Therefore, **NEVER** operate the pump with the air motor plates removed. **KEEP CLEAR** of moving parts when starting or operating the pump. Before checking or servicing the pump, follow the **Pressure Relief Procedure** on page 2 to prevent the pump from starting accidentally.

**HANDLE AND ROUTE HOSES CAREFULLY.** Do not pull on hoses to move equipment. Do not use fluids or solvents which are not compatible with the inner tube and cover of the hose.

### Hose Grounding Continuity

Proper hose grounding continuity is essential to maintaining a grounded spray system. Check the electrical resistance of your air and fluid hoses at least once a week. If your hose does not have a tag on it which specifies the maximum electrical resistance, contact the hose supplier or manufacturer for the maximum resistance limits. Use a resistance meter in the appropriate range for your hose to check the resistance. If the resistance exceeds the recommended limits, replace it immediately. An ungrounded or poorly grounded hose can make your system hazardous. Also, read **FIRE OR EXPLOSION HAZARD**, above.

## IMPORTANT



## TYPICAL INSTALLATION

### KEY

- A Bleed-type Master Air Valve
- B Pump Runaway Valve
- C Air Line Filter
- D Air Line Lubricator
- E Pump Air Regulator
- H Drain Valve
- J Pump Ground Wire
- K Grounded Fluid Hose
- L Grounded Air Hose
- 20 Relax-A-Valve
- 21 Drain Back Tube

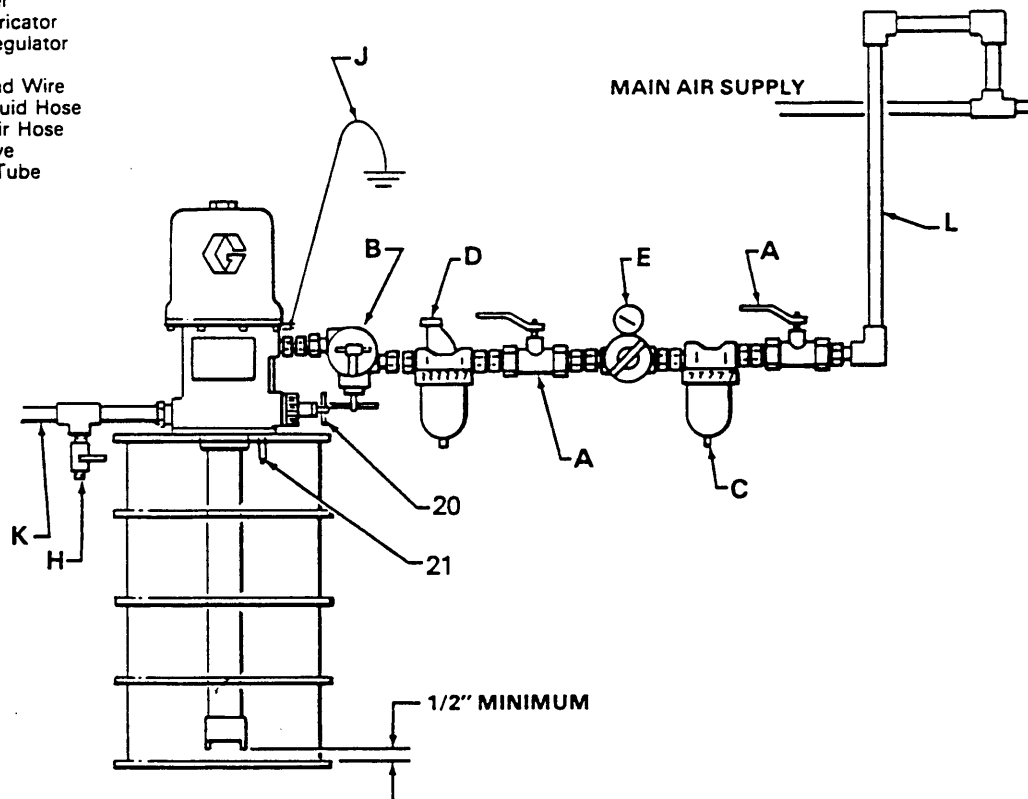

## INSTALLATION

**NOTE:** Reference numbers and letters in parentheses in the text refer to the callouts in the figure illustrations and the parts drawings.

See page 17 for accessories that are available from Graco.

The Typical Installation shown above is only a guide to selecting and installing required and optional accessories. For assistance in designing a system to suit your needs, contact your Graco representative.

Mount the pump to suit the type of installation planned. The pump dimensions and mounting hole layout are shown on pages 15 and 16.

### Model 205-626 only

This stubby pump can be mounted directly in a drum or supply tank suction line, or on a wall bracket. By screwing an accessory extension tube directly into the pump's intake valve, this pump can also be used in a drum or tank. Extension tubes are available in 28 in. (711 mm) and 38 in. (965 mm) lengths. See Accessories.

### Pail or Drum Length Pumps

Install the pump in the drum or pail, using a suitable cover, bung adapter or mounting clamp. The pump must be 1/2 in. (13 mm) off the bottom of the pail or drum.

If the pump has a drain back tube, connect a drain hose to it and route the hose back to the supply container.

**NOTE:** In a closed-head drum, be sure to loosen the vent plug in the drum cover to prevent formation of a vacuum.

### WARNING

Two accessories are required in your system: a bleed-type master air valve (A), if your pump does not have a Relax-A-Valve, and a fluid drain valve (H). These accessories help reduce the risk of serious bodily injury including injection, splashing in the eyes, and injury from moving parts if you are adjusting or repairing the pump.

The bleed-type master air valve relieves air trapped between this valve and the pump after the air regulator is shut off. Trapped air can cause the pump to cycle unexpectedly. Locate the valve close to the pump.

The fluid drain valve assists in relieving fluid pressure in the displacement pump, hose and gun; triggering the gun to relieve pressure may not be sufficient.

### Pumps with Relax-A-Valve

An Evenflo air regulator may be installed on pumps having a Relax-A-Valve. This regulator prevents initial surging of non-atomized fluid when the gun is triggered. Air pressure in the pump is relieved automatically each time the gun trigger is released. When used with a Relax-A-Valve set in the automatic position, fluid pressure is relieved automatically also.

Installation continued on page 5

### All Pumps

Install the air line accessories in the approximate order shown in the Typical Installation drawing. A pump runaway valve (B) senses when the pump is running too fast and shuts off the air supply to the motor. For automatic air motor lubrication, install an air line lubricator (D). (For manual lubrication, see MAINTENANCE, page 6.) Install the bleed-type master air valve (A) *within* easy reach of the pump. Install an air regulator (E) to control air to the motor and pump speed. An air line filter (C) removes harmful dirt and moisture from your compressed air supply.

Be sure the air supply hose is properly grounded, and is at least 1/2 in. (13 mm) ID in order to supply an adequate volume of air to the motor.

## OPERATION

### Startup

The pump was tested in oil, and some oil was left in the pump to protect it from corrosion. If the oil will contaminate the fluid you are pumping, flush it out.

To start the pump, close the fluid drain valve (H). Open the bleed-type master air valves (A). Holding a metal part of the spray gun/dispensing valve firmly against the side of a grounded metal pail, hold the trigger open while slowly opening the air regulator (E). Run the pump *slowly* until all air is purged from the gun/valve. Release the trigger and engage the safety latch (if applicable).

Use the air regulator (E) to control fluid pressure and pump speed. Always use the lowest pressure necessary to get the desired results. Higher pressures cause premature pump wear and spray tip wear, and usually do not improve the spray pattern.

### WARNING

To reduce the risk of overpressurizing your system, which could result in component rupture and cause serious bodily injury, NEVER exceed the maximum working pressure of the lowest rated component in your system. Lowering the air pressure to the motor will proportionately lower the fluid outlet pressure from the pump. Refer to **EQUIPMENT MISUSE HAZARD, System pressure**, for the maximum air and fluid working pressure of this pump.

In a direct supply system, with adequate air pressure supplied to the motor, the pump starts when the gun or dispensing valve is opened, and stalls against pressure when it is closed.

If the pump accelerates quickly or is running too fast, stop it immediately. Check the fluid supply and refill it if necessary. Prime the pump to remove all air from the system, or flush the pump, relieve pressure, but leave the system filled with mineral spirits or an oil-based solvent to protect the pump from corrosion.

**NOTE:** A pump runaway valve (B) can be installed on the air line to automatically shut off the pump if it starts to run too fast.

### Shutdown and Care of the Pump

Always stop the pump at the bottom of its stroke to prevent fluid from drying on the rod and damaging the throat packings.



On the fluid line, install a drain valve (H) close to the fluid outlet to assist in relieving fluid pressure (not required with pumps having a Relax-A-Valve). Connect a suitable, grounded fluid hose and spray gun or dispensing valve to the pump's 3/4 in. npt outlet.

### Grounding

Proper grounding is essential to maintain a safe system. Read **FIRE OR EXPLOSION HAZARD** on page 3, then ground the pump and system as explained in that section.

### WARNING

Always follow the **Pressure Relief Procedure** on page 2 whenever you stop spraying and before checking, or repairing any part of the system, to reduce the risk of serious bodily injury.

If you are pumping fluid which dries, hardens or sets up, flush the system with a compatible solvent as often as necessary to prevent a build up of dried fluid in the pump or hoses.

### Using the Relax-A-Valve

If your pump has a Relax-A-Valve, it can be used to mix fluid by circulation (except in inductor-type follow plate installations), and it can be set to relieve fluid line pressure each time the pump air pressure is relieved.

*To circulate fluid*, open the Relax-A-Valve by loosening the locknut (119) and turning the T-handle screw (110) *counterclockwise* as far as possible. Start the pump and circulate the fluid as necessary. Stop the pump and close the Relax-A-Valve or set it in the automatic position. See Fig 2.

*To set the automatic position*, loosen the locknut (119) and turn the T-handle screw (110) *clockwise* as far as possible. Back off the T-handle screw *four* turns and tighten the locknut. During normal operation, the fluid pressure is relieved automatically each time the air pressure to the pump is relieved.

**NOTE:** If your installation includes an Evenflo pressure regulator, air to the pump is automatically relieved each time you close the gun trigger, and the Relax-A-Valve, in turn, relieves fluid pressure.

Without an Evenflo, the bleed-type master air valve (A) should be used to relieve pump air pressure.

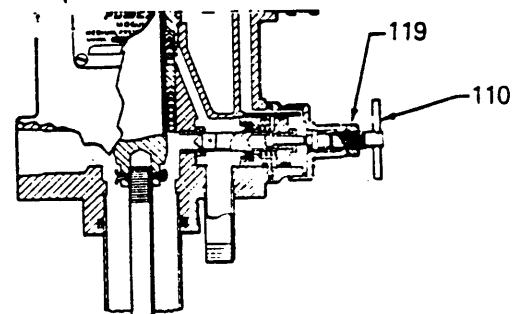

Fig 2

## MAINTENANCE

### Lubrication

If your system includes an automatic air line lubricator, adjust the lubricator as instructed in the separate instruction manual.

For manual lubrication, *each day*, remove the air inlet hose and place 12 to 15 drops of high quality, light motor oil in the inlet. Reattach the hose and turn on the air to blow the oil into the motor.

### Throat Packing Adjustment

*Once a week, or after each 40 hours of operation*, check the tightness of the throat packing nut. It should be tight enough to stop leakage, but no tighter.

To check, first follow the **Pressure Relief Procedure Warning**, page 7. Then remove the identification plate (M) from the motor. Using a spanner wrench or a 0.22 in. (5.6 mm) diameter rod, adjust the nut. Reinstall the identification plate before operating the pump. See Fig 3.

### Flushing

To reduce the risk of injection injury, static sparking, or splashing in the eyes or on the skin, follow the **Pressure Relief Procedure** on page 2, and *remove the spray tip (spray guns or spray valves only) before flushing*. Hold a metal part of the gun/valve firmly to the side of a grounded *metal* pail and use the lowest possible fluid pressure during flushing.

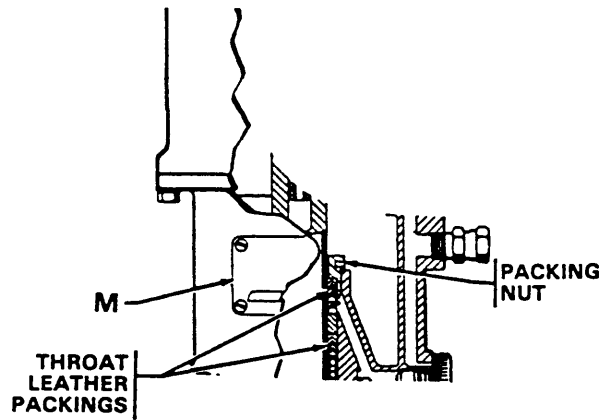

Fig 3

### Corrosion Protection

#### CAUTION

Water, or even moist air, can cause your pump to corrode. To help prevent corrosion, NEVER leave the pump filled with water-based fluid or air. After normal flushing, flush the pump again with mineral spirits or oil-based solvent, and relieve pressure. This leaves the mineral spirits in the pump. Be sure to follow all steps of the **Pressure Relief Procedure** on page 2.

# TROUBLESHOOTING CHART



## WARNING

### Pressure Relief Procedure

To reduce the risk of serious bodily injury, including fluid injection, splashing in the eyes or on the skin, or injury from moving parts, follow this procedure whenever you shut off the pump, when checking or repairing any part of the system, when installing, cleaning or changing spray tips, and whenever you stop spraying. (1) Engage the gun safety latch. (2) Close the pump air regulator. (3) Close the bleed-type master air valve. (4) Disengage the gun safety latch. (5) Hold a metal part of the gun firmly to the side of a grounded metal pail, and trigger the gun to relieve pressure. (6) Engage the gun safety latch. (7) Open the drain valve, having a container ready to catch the drainage. (8) Leave the drain valve open until you are ready to spray again.

*If you suspect that the spray tip or hose is completely clogged, or that pressure has not been fully relieved after following the steps above. VERY SLOWLY* loosen the tip guard retaining nut or hose end coupling and relieve pressure gradually, then loosen completely. Now clear the tip or hose obstruction.

## WARNING

Never operate the pump with the air motor plate removed. Moving parts in the piston can pinch or amputate fingers.

PROBLEM	CAUSE	SOLUTION*
Pump does not operate, or no fluid flow	Loose or broken pump parts	Disassemble, check, repair
	Restricted line or inadequate air supply	Clear, increase
	Exhausted fluid supply	Refill and prime
	Clogged fluid hoses	Clean, or replace
	Fluid intake or piston valves need adjustment	Adjust, see page 9
Pump operates but output is low	Damaged air motor	Repair; see 306-982
	Insufficient air supply	Increase
	Exhausted fluid supply	Refill and prime
	Obstructed gun or dispensing valve	Clear
	Damaged fluid pump packings	Replace, see page 8
Erratic or accelerated operation	Held open or worn piston or intake valve	Repair. See 307-719
	Exhausted fluid supply	Refill and prime
	Fluid intake or piston valve worn	Repair; see page 8

\*Always follow the Pressure Relief Procedure Warning first!

## Displacement Pump Repair

### Before you start:

1. A packing repair kit, part no. 206-927, is available. This kit includes two glands and eight packings for the motor as well as o-rings, packings and washers for the displacement pump. For the best results, use all the parts in the kit.
2. Clean all parts as you disassemble them, using a compatible solvent, and inspect for wear or damage. Replace parts as necessary.

### Intake Valve (See Fig 4)

1. Follow the **Pressure Relief Procedure Warning** on page 7.
2. Unscrew the intake valve housing (15).

*Models 205-626, 222-065, and 222-095:* Inspect the ball (4) and the seat in the housing (15) for nicks or scratches.

*Models 205-627 and 205-628:* Remove the ball stop pin (17). Inspect the ball (4) and seat (19a) for nicks or scratches.

*All Models:* Replace the ball and/or seat if it is damaged, as damaged parts do not seal properly and may cause poor pump performance.

3. If no further service is needed, reassemble the intake valve. For Models 205-627 and 205-628, be sure the ball stop pin (17) is reinstalled in the proper holes. See **Check Valve Adjustment** on page 9.

### Piston

4. Unscrew the riser tube (9) from the pump base. Clean the tube and inspect it for wear by holding it up to a light at a slight angle. If you see wavy lines or scratches where the piston travels, replace the tube as it will not seal well with the new piston packings and the pump will perform poorly.
5. Loosen the locknut (2) and unscrew the piston (8) from the connecting rod (16).
6. Disassemble and clean all parts.
7. Reassemble the piston, using all the new parts from the kit and any other new parts needed. Oil the leather packings (10\*) first. Then assemble the parts on the piston seat (7) in this order: backup washer (13), spreader (11), leather packing (10\*), spacer (14) with a new o-ring (5) installed in it, another leather packing (10\*), spreader (11) and backup washer (13\*).

**NOTE:** To replace the throat packings, follow the procedure given in your separate air motor manual, 306-982, supplied, before continuing with this procedure.

8. Apply sealant to the threads of the seat (7) and screw onto the piston body (8). Screw the piston onto the connecting rod (16) and adjust the ball travel as instructed in **Check Valve Adjustment** on page 9. Tighten the locknut (2).
9. Check the o-ring (6) in the pump base and replace it if necessary.

MODELS  
205-627 &  
205-628

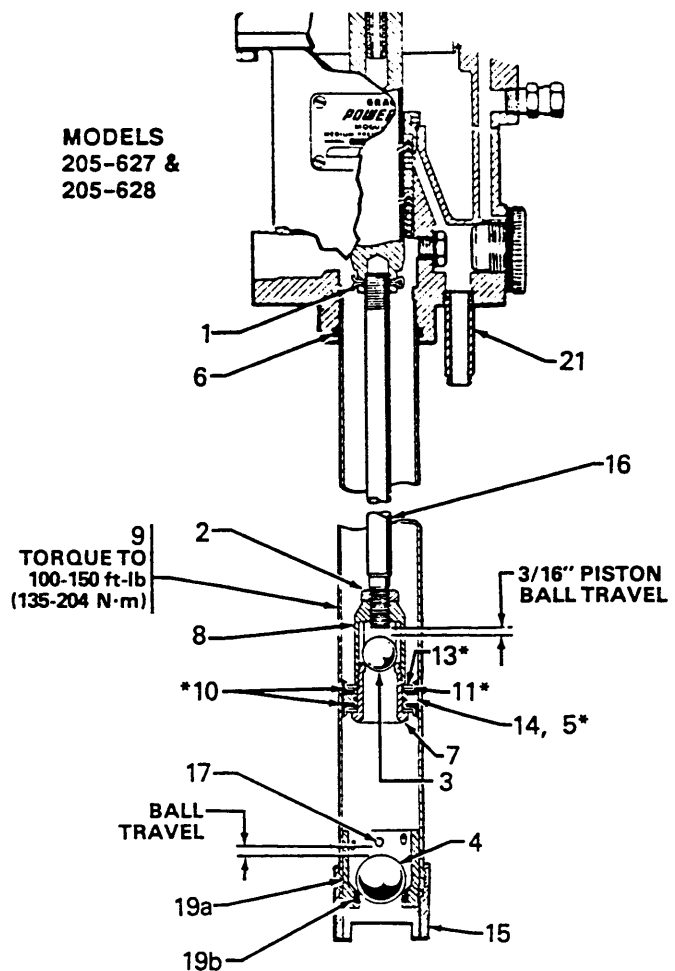

MODELS  
205-626,  
222-065,  
& 222-095

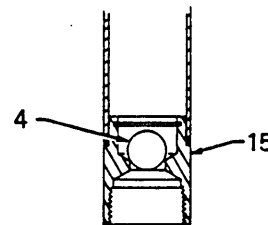

Fig 4

10. Lubricate the piston packings and the inner wall at the top of the riser tube (9). Wrap the packings with a guide collar made of 1/64 in. maximum thickness shim stock or metal sheeting. Using a turning motion, work the first leather packing into the riser tube. Remove the guide collar and push the riser tube up and screw it into the base. Torque the tube to 100-150 ft-lb (135-204 N·m).

### Reassembly

1. Be sure the check valves are properly adjusted. See page 9.
2. Reinstall the intake valve.
3. Reconnect the pump's ground wire to a true earth ground.

8

### Check Valve Adjustment

Models 205-627 and 205-628 have adjustable fluid intake and piston ball checks, which are factory-set for medium viscosity fluids.

**To change the piston ball travel,** loosen the locknut (2). Turn the piston body (8) *counterclockwise to increase*, and *clockwise to decrease*. Medium viscosity fluids should have a 3/16 in. (5 mm) ball travel. See Fig 5. Decreasing the ball travel minimizes surging at stroke changeover, but too short a ball travel restricts the flow and slows down the pump.

**To change the intake valve ball travel,** move the ball stop pin (17) to a higher or lower set of holes. Use the middle holes for medium viscosity fluids.

### Relax-A-Valve Repair

To remove an obstruction from the valve, loosen the locknut (119) and turn the T-handle completely counterclockwise. Turn on the pump and operate to flush out the obstruction. Stop the pump and follow the **Pressure Relief Procedure Warning**. Reset the Relax-A-Valve to the automatic position. See page 5.

If further repair is needed, relieve pressure. Unscrew the valve housing (114) and seat (118) from the pump base. See Fig 6.

Clean and inspect the seat and tip (117c) for wear or damage, replacing parts as necessary.

Check the piston travel. Unscrew the cap (115) from the housing. Check for a 1/4 in. (6 mm) clearance between the stop nut (112) and the jam nut (103). If adjustment is necessary, loosen the jam nut (103) and turn the adjusting stem (111) in or out until you obtain the proper clearance. See Fig 6. Tighten the jam nut.

Reassemble the Relax-A-Valve in the reverse order.

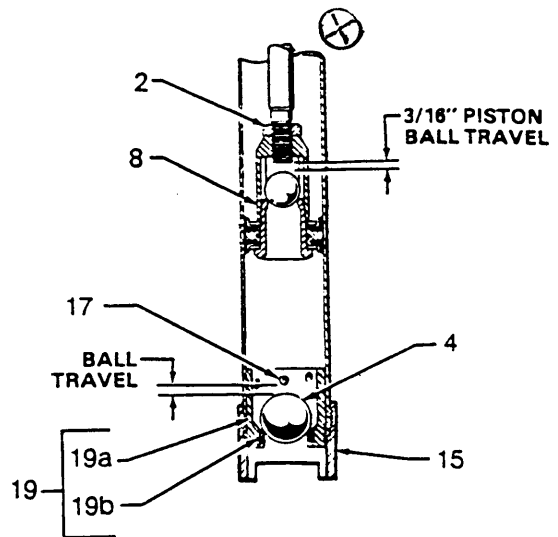

Fig 5

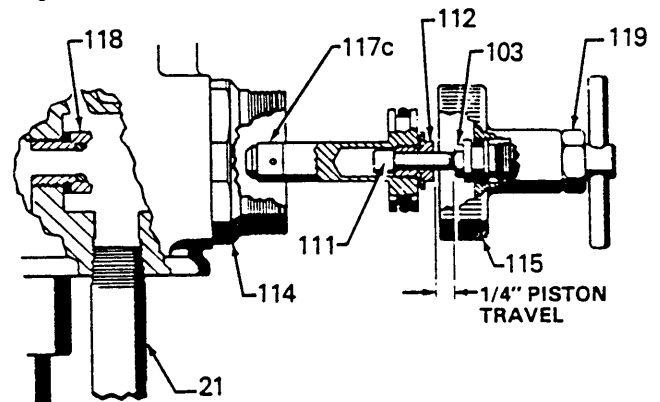

Fig 6

**PARTS DRAWING**



**Model 222-065, Series A**  
Includes items 1-31

REF NO.	PART NO.	DESCRIPTION	QTY
1	100-103	PIN, cotter; 1/8" dia x 1-1/2"	1
2	100-111	NUT, hex, jam; 1/2-20	1
3	100-279	BALL, steel; 7/8" dia.	1
4	101-190	BALL, steel; 1" dia.	1
5	154-662*	O-RING; buna-N	1
6	156-641	O-RING; buna-N	1
7	156-989	SEAT, fluid piston valve	1
8	157-184	BODY, fluid piston	1
9	183-010	TUBE, riser	1
10	158-402*	PACKING, cup; leather	2
11	171-590*	WASHER, spreader	2
13	171-594*	WASHER, backup	2
14	158-857	SPACER, fluid piston packing	1
15	183-009	HOUSING, intake valve	1
16	159-320	ROD, conn.; 2.325" (59 mm)	1
17	157-182	STOP, ball, intake valve	1
18	205-647	AIR MOTOR	1
		See 306-982 for parts	1
22	159-445	PLUG; 1-3/8-12 NF2 thread	1
23	159-446	GASKET; vellumoid	1
24	159-890	GASKET; copper	1
25	157-834	PLUG; 5/8-18 NF2 thread	1
30	156-633	O-RING; buna-N	1
31	220-688	SUCTION TUBE ASSEMBLY	1
		Includes items 31a and 31b	
31a	183-013	TUBE	1
31b	183-017	SPACER	1

\* Included in repair kit 206-927.

See "How to Order Replacement Parts" on page 14.

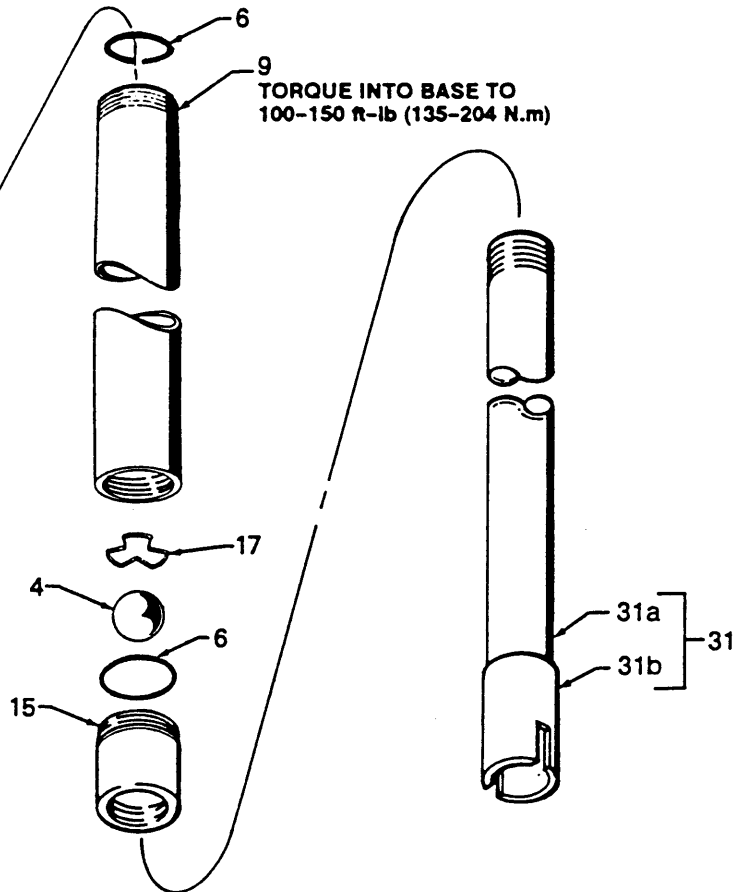
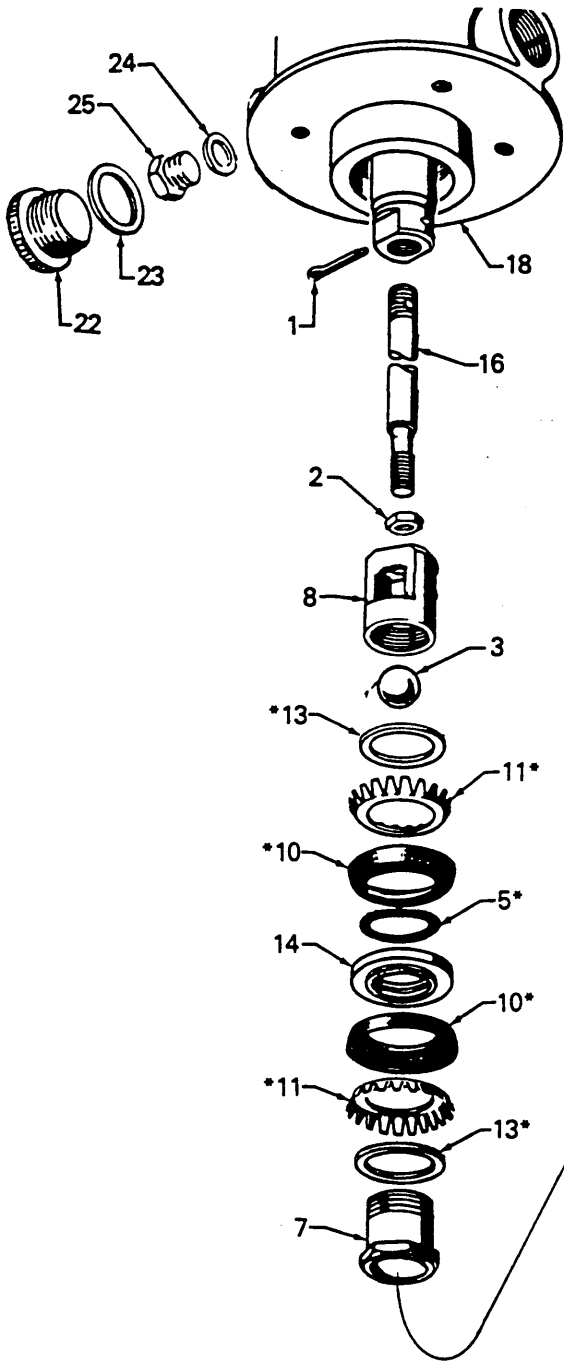

10

# PARTS DRAWING



Model 222-095, Series A  
Includes items 1-31

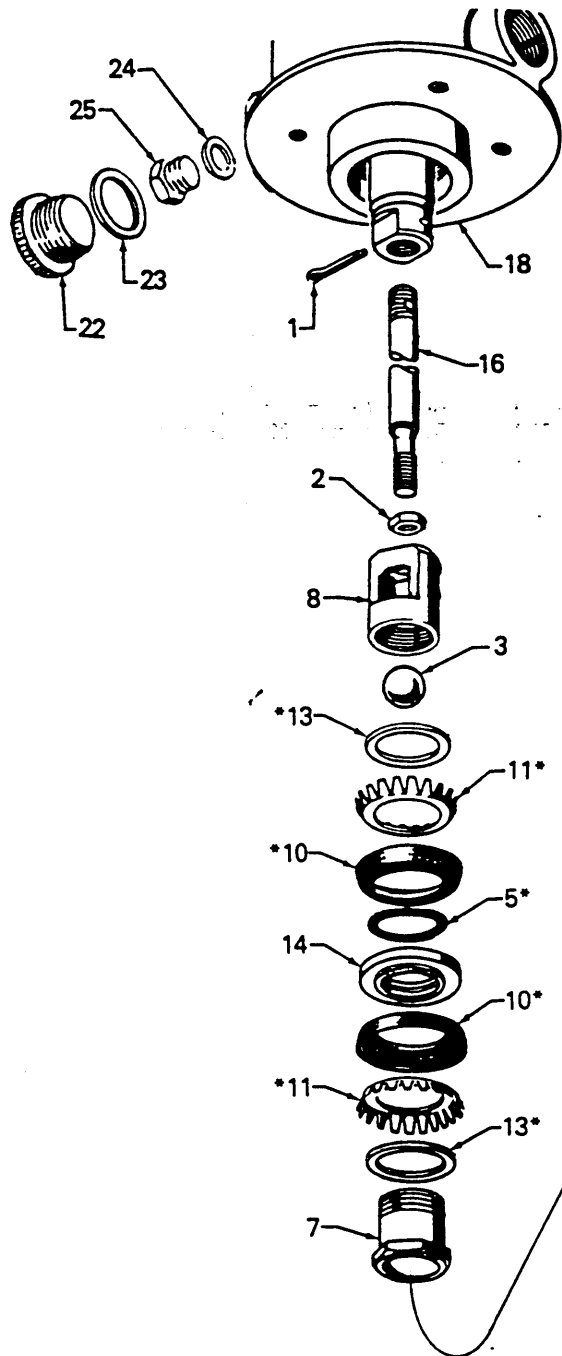

REF NO.	PART NO.	DESCRIPTION	QTY
1	100-103	PIN, cotter; 1/8" dia x 1-1/2"	1
2	100-111	NUT, hex, jam; 1/2-20	1
3	100-279	BALL, steel; 7/8" dia.	1
4	101-190	BALL, steel; 1" dia.	1
5	154-662*	O-RING; buna-N	1
6	156-641	O-RING; buna-N	1
7	156-989	SEAT, fluid piston valve	1
8	157-184	BODY, fluid piston	1
9	183-010	TUBE, riser	1
10	158-402*	PACKING, cup; leather	2
11	171-590*	WASHER, spreader	2
13	171-594*	WASHER, backup	2
14	158-857	SPACER, fluid piston packing	1
15	183-009	HOUSING, intake valve	1
16	159-320	ROD, conn.; 2.325" (59 mm)	1
17	157-182	STOP, ball, intake valve	1
18	205-647	AIR MOTOR	1
22	159-445	PLUG; 1-3/8-12 NF2 thread	1
23	159-446	GASKET; vellumoid	1
24	159-890	GASKET; copper	1
25	157-834	PLUG; 5/8-18 NF2 thread	1
28	222-308	BUNG ADAPTER ASSEMBLY	1
28a	104-542	SCREW, cap, hex hd; M8 x 1.25	1
28b	210-834	ADAPTER, bung	1
30	156-633	O-RING; buna-N	1
31	220-690	SUCTION TUBE ASSEMBLY	1
31a	183-015	TUBE	1
31b	183-017	SPACER	1

\* Included in repair kit 206-927.

See "How to Order Replacement Parts" on page 14.

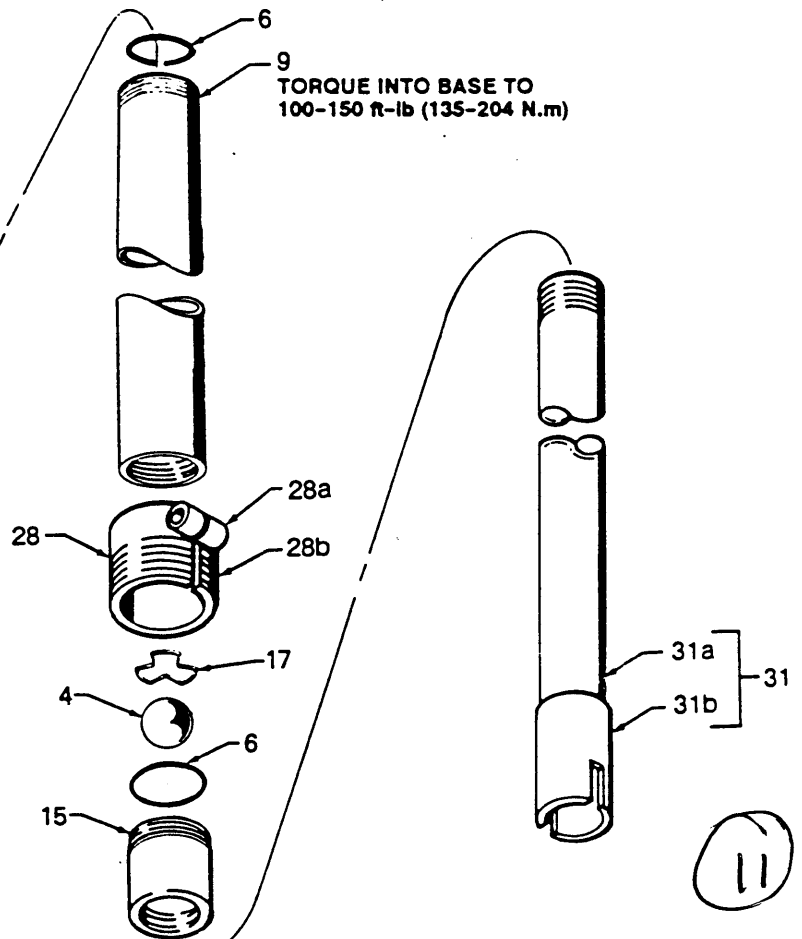

PARTS DRAWING



Model 205-626, Series H  
Includes items 1-30

REF NO.	PART NO.	DESCRIPTION	QTY
1	100-103	PIN, cotter; 1/8" dia x 1-1/2"	1
2	100-111	NUT, hex, jam; 1/2-20	1
3	100-279	BALL, steel; 7/8" dia.	1
4	101-190	BALL, steel; 1" dia.	1
5	154-662*	O-RING; buna-N	1
6	156-641	O-RING; buna-N	1
7	156-989	SEAT, fluid piston valve	1
8	157-184	BODY, fluid piston	1
9	183-010	TUBE, riser	1
10	158-402*	PACKING, cup; leather	2
11	171-590*	WASHER, spreader	2
13	171-594*	WASHER, backup	2
14	158-857	SPACER, fluid piston packing	1
15	183-009	HOUSING, intake valve	1
16	159-320	ROD, conn.; 2.325" (59 mm)	1
17	157-182	STOP, ball, intake valve	1
18	205-647	AIR MOTOR	1
		See 306-982 for parts	1
22	159-445	PLUG; 1-3/8-12 NF2 thread	1
23	159-446	GASKET; vellumoid	1
24	159-890	GASKET; copper	1
25	157-834	PLUG; 5/8-18 NF2 thread	1
30	156-633	O-RING; buna-N	1

\* Included in repair kit 206-927.

See "How to Order Replacement Parts" on page 14.

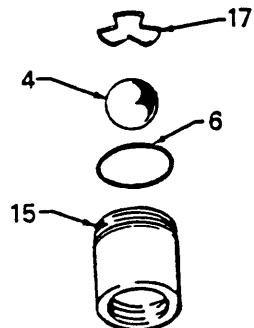
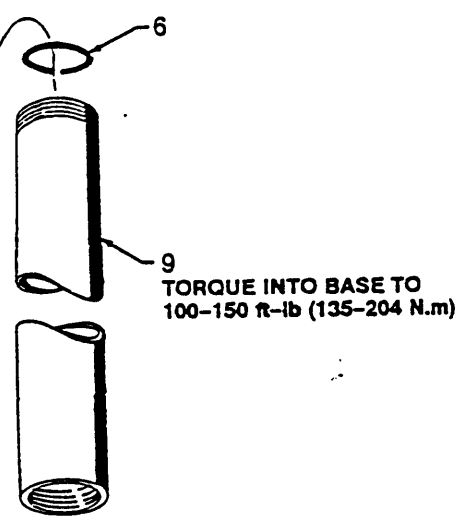
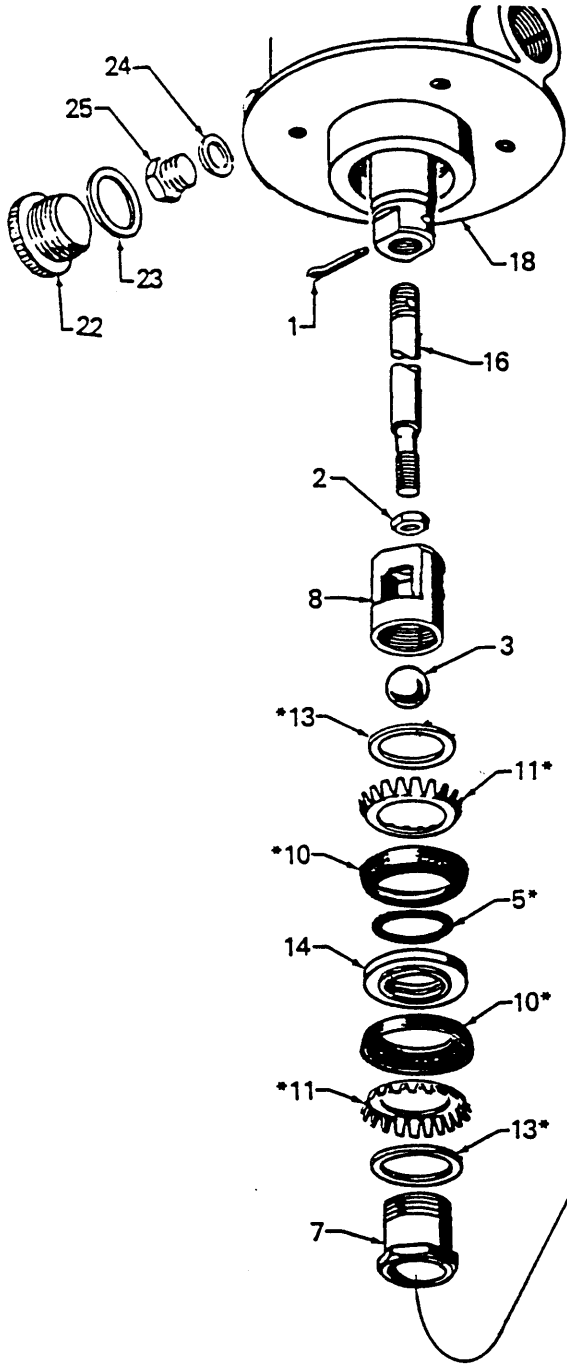

**PARTS DRAWING**

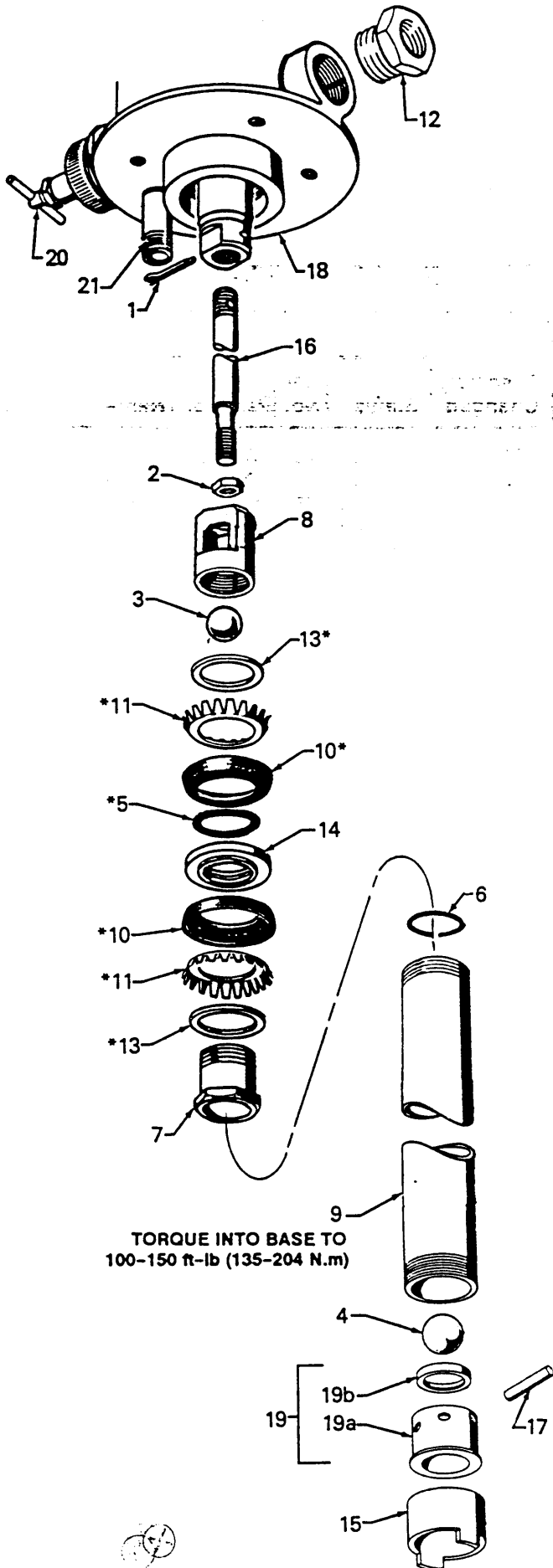

**Model 205-628, Series H**  
Includes items 1-21

REF NO.	PART NO.	DESCRIPTION	QTY
1	100-103	PIN, cotter; 1/8" dia. x 1-1/2"	1
2	100-111	NUT, hex, jam; 1/2-20	1
3	100-279	BALL, steel; 7/8" dia.	1
4	101-178	BALL, steel; 1-1/4" dia.	1
5	*154-662	O-RING, buna-N	1
6	156-641	O-RING, buna-N	1
7	156-989	SEAT, fluid piston valve	1
8	157-184	BODY, fluid piston	1
9	158-399	TUBE, riser; 32.75" (832 mm)	1
10	*158-402	PACKING, cup, leather	2
11	*171-590	WASHER, spreader	2
12	158-586	BUSHING, pipe; 1" x 3/4 npt	1
13	*171-594	WASHER, backup	2
14	158-857	SPACER, fluid piston packing	1
15	159-839	HOUSING, intake valve	1
16	164-928	ROD, conn; 25.325" (643 mm)	1
17	160-726	PIN, ball stop, intake valve	1
18	205-647	AIR MOTOR	1
19	204-762	FOOT VALVE BODY & SEAT ASSEMBLY; Includes items 19a & 19b	1
19a	161-521	.SEAT, foot valve	1
19b	161-820	.SEAT, ball	1
20	206-280	RELAX-A-VALVE ASSEMBLY See parts list on page 14	1
21	100-992	TUBE, drain back	1

\*included in repair kit 206-927.

See "How to Order Replacement Parts" on page 14.

**Model 205-627, Series G**  
Includes items 1-21

REF NO.	PART NO.	DESCRIPTION	QTY
1	100-103	PIN, cotter; 1/8" dia. x 1-1/2"	1
2	100-111	NUT, hex, jam; 1/2-20	1
3	100-279	BALL, steel; 7/8" dia.	1
4	101-178	BALL, steel; 1-1/4" dia.	1
5	*154-662	O-RING, buna-N	1
6	156-641	O-RING, buna-N	1
7	156-989	SEAT, fluid piston valve	1
8	157-184	BODY, fluid piston	1
9	159-258	TUBE, riser; 17" (432 mm)	1
10	*158-402	PACKING, cup, leather	2
11	*171-590	WASHER, spreader	2
12	158-555	NIPPLE, reducing; 1" x 3/4 npt	1
13	*171-594	WASHER, backup	2
14	158-857	SPACER, fluid piston packing	1
15	159-839	HOUSING, intake valve	1
16	164-927	ROD, conn; 9.625" (244.5 mm)	1
17	160-726	PIN, ball stop, intake valve	1
18	205-647	AIR MOTOR	1
19	204-762	FOOT VALVE BODY & SEAT ASSEMBLY; Includes items 19a & 19b	1
19a	161-521	.SEAT, foot valve	1
19b	161-820	.SEAT, ball	1
20	206-280	RELAX-A-VALVE ASSEMBLY See parts list on page 14	1
21	100-992	TUBE, drain back	1

\*Included in repair kit 206-927.

See "How to Order Replacement Parts" on page 14.

# PARTS LIST

Ref No. 20  
Relax-A-Valve Assembly  
Includes items 101 to 119

REF NO.	PART NO.	DESCRIPTION	QTY
101	100-694	LOCKWASHER, internal, shkprf; 7/16"	1
102	100-992	TUBE, drain back	1
103	101-345	NUT, hex, jam; 1/4-20	1
104	101-389	SEAL, leather	1
105	153-996	SPRING, compression	1
106	154-594	O-RING, Buna-N®	1
107	154-662	O-RING	2
108	155-508	GASKET, vellumoid	1
109	156-633	O-RING, Buna-N®	1
110	157-131	HANDLE, valve tee	1
111	158-389	STEM, adjusting	1
112	158-390	NUT, stop	1
113	158-391	SCREW, adjusting	1
114	158-393	HOUSING, relax-a-valve	1
115	158-396	CAP, relax-a-valve	1
116	159-890	GASKET, copper	1
117	203-376	STEM ASSEMBLY Includes items 117a-117c	1
117a	159-050	.STEM, valve	1
117b	101-379	.PIN, spring, straight	1
117c	203-375	.TIP, needle valve	1
118	203-374	SEAT ASSEMBLY	1
119	100-111	NUT, hex, jam; 1/2-20	2

Pump Packing Repair Kit 206-927   
(Must be ordered separately)  
Includes:

Ref No.	Qty.
5	1
10	2
11	2
13	2

Also includes packings and glands for the air motor.

## SERVICE INFORMATION

Listed below by the assembly changed are DELETED parts.

Assembly Changed	Status	Ref No.	Part No.	Name
205-626 Pump	Deleted	12	158-555	Nipple
	Deleted	21	100-992	Tube
	Deleted	26	204-594	Cup Support
	Deleted	27	152-146	Weep Cup
	Deleted	29	100-081	Bushing

MODEL NOTE: Model 205-629 is obsolete and has been removed from the manual. New Models 222-065 and 222-095 have been added.

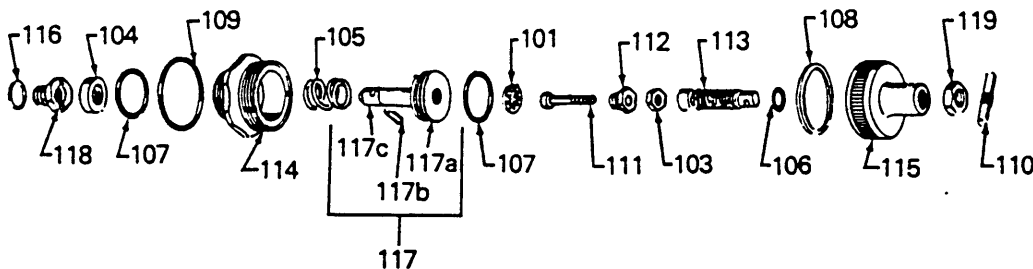

## HOW TO ORDER REPLACEMENT PARTS

- To be sure you receive the correct replacement parts, kit or accessories, always give all of the information requested in the chart below.
- Check the parts list to identify the correct part number; **do not use the ref. no. when ordering.**
- Order all parts from your nearest Graco distributor.

6 digit PART NUMBER	QTY	PART DESCRIPTION

**DIMENSIONS**

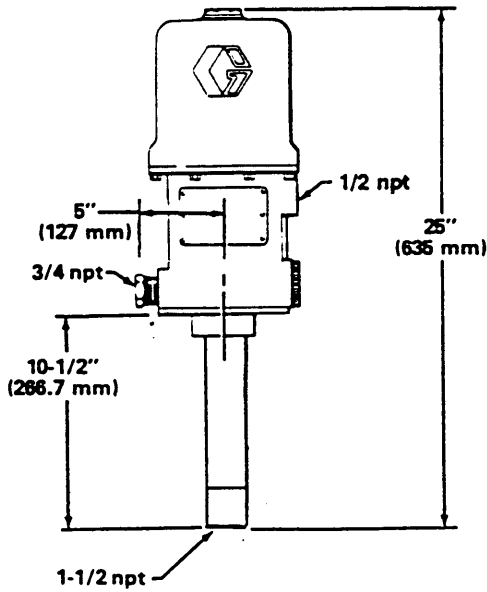

**Model 205-626, Series H**  
Weight: 29 lb (13 Kg)

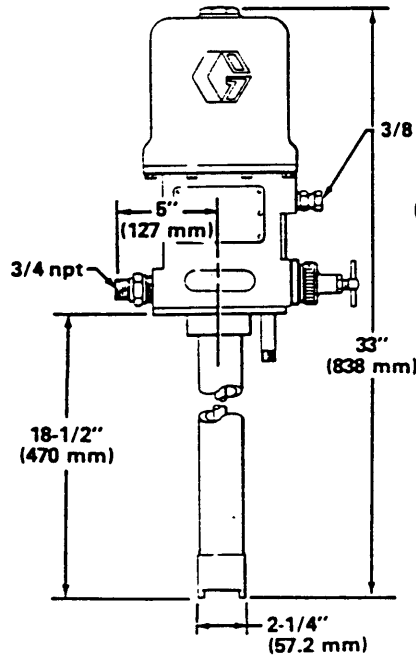

**Model 205-627, Series G**  
Weight: 29 lb (13 Kg)

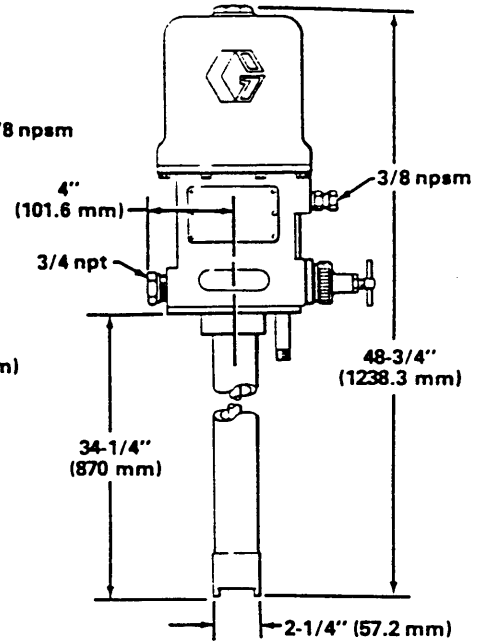

**Model 205-628, Series H**  
Weight: 40 lb (18 Kg)

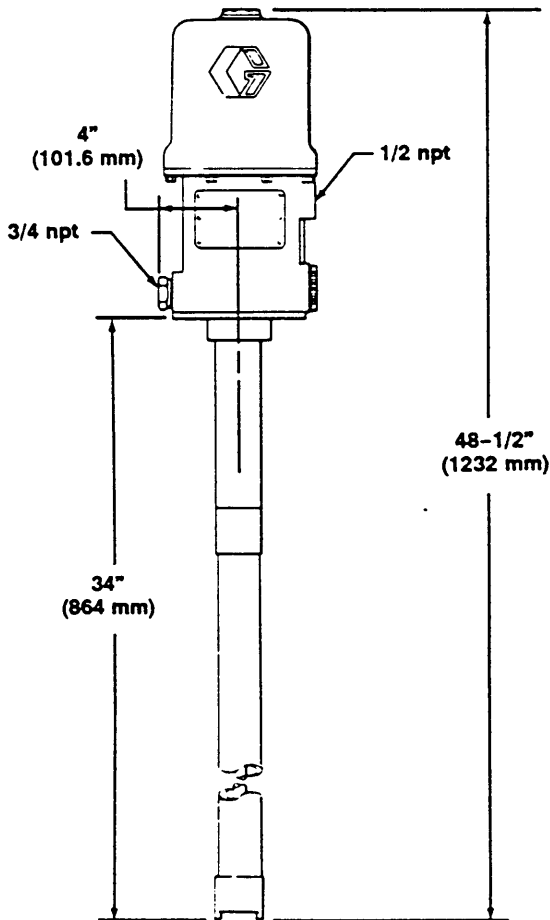

**Model 222-065, Series A**  
Weight: 33 lb (15 kg)

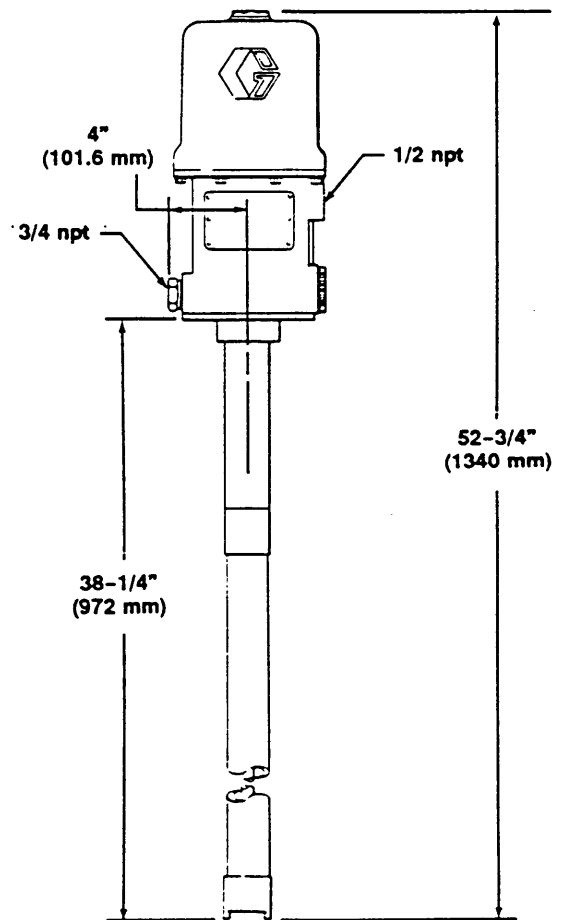

**Model 222-095, Series A**  
Weight: 33 lb (15 kg)

DIMENSIONS (Continued)

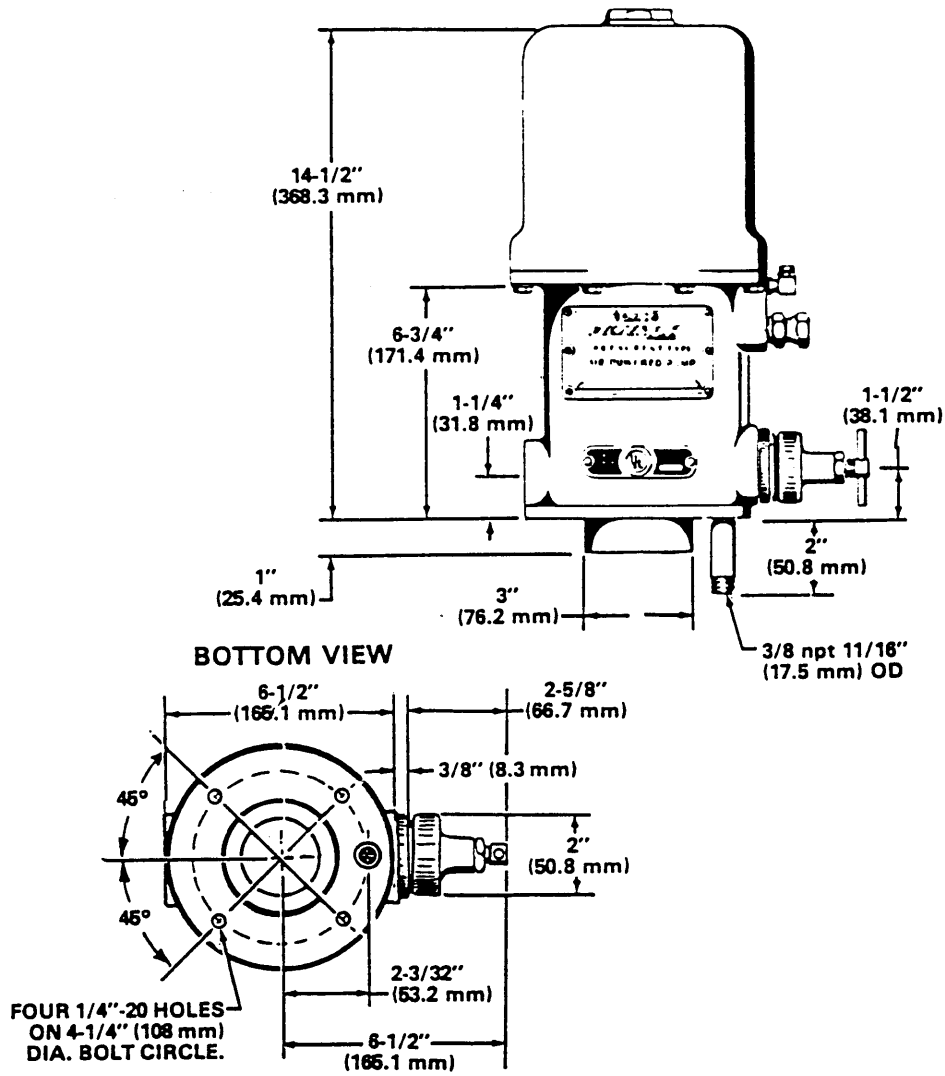

**ACCESSORIES (Must be purchased separately)**

**AIR LINE FILTER**

250 psi (17.5 bar) MAXIMUM WORKING PRESSURE

- 106-149 1/2 npt inlet & outlet
- 106-150 3/4 npt inlet & outlet



**GROUNDING CLAMP 103-538**

**GROUND WIRE 208-950**  
25 ft (7.6 m) length, 12 ga.  
For grounding pump.

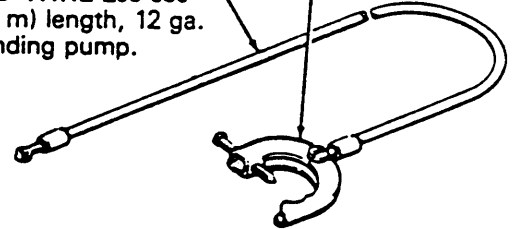

**AIR LINE OILER**

250 psi (17.5 bar) MAXIMUM WORKING PRESSURE

- 214-848 1/2 npt inlet & outlet
- 214-849 3/4 npt inlet & outlet

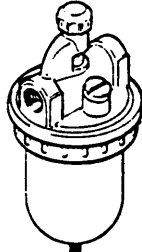

**STURDI-CLAMP 203-156**

For mounting bung pump to side of open drum.

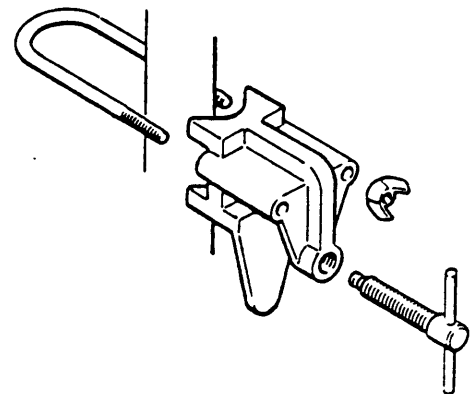

**BLEED-TYPE MASTER AIR VALVE (REQUIRED)**

300 psi (21 bar) MAXIMUM WORKING PRESSURE

Relieves air trapped in the air line between the pump air inlet and this valve when closed.

- 107-141 3/4 npt(m x f) inlet & outlet
- 107-142 1/2 npt(m x f) inlet & outlet

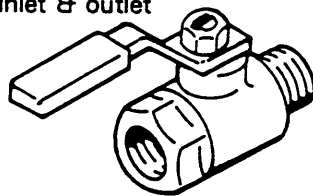

**HIGH PRESSURE BALL VALVES, Viton Seals**

5000 psi (350 bar) MAXIMUM WORKING PRESSURE  
Can be used as fluid drain valve.

- 210-657 1/4 npt(m)
- 210-658 3/8 npt(m)
- 210-659 3/8 x 1/4 npt(m)

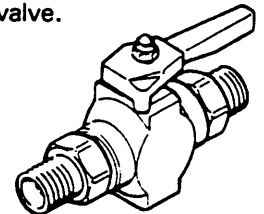

**AIR REGULATOR 203-716**

300 psi (21 bar) MAXIMUM INBOUND AIR PRESSURE

0-200 psi (0-14 bar) Regulated Pressure Range  
1/2 npsm(f) inlet, 3/8 npt(m) outlet

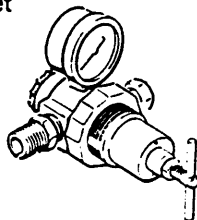

**SWIVEL 207-947**

3000 psi (210 bar) MAXIMUM WORKING PRESSURE

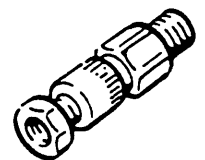

**PUMP RUNAWAY VALVE 215-362**

Shuts off air to pump automatically if it senses that the pump is running too fast, a condition caused by a depleted fluid supply.

3/4 npt(f) inlet and outlet.

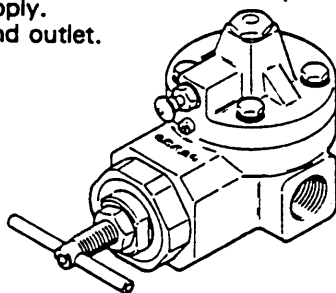

**EVENFLO CONTROL 202-844**

175 psi (12 bar) MAXIMUM AIR INLET PRESSURE

Used with a Relax-A-Valve equipped pump and heavy fluid air spray gun, prevents initial surging of non-atomized fluid when gun is triggered on.

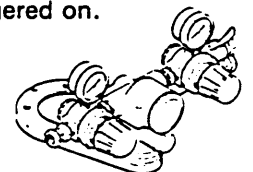

**EXTENSION TUBES**

Screws directly into intake valve of stubby pump  
205-626 to convert pump to drum or tank length.

- 183-257 28 in. (711 mm)
- 183-258 38 in. (965 mm)

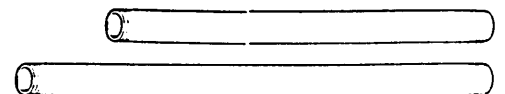

17

## TECHNICAL DATA



Fluid pressure ratio	: 10:1
Air pressure operating range	: 40-180 psi (3-12 bar)
Maximum fluid working pressure	: 1800 psi (124 bar)
Maximum recommended pump speed	: 60 cycles/minute
Delivery (continuous duty)	: 3 gpm (12 liter/min)
Delivery (intermittent duty)	: 6 gpm (25 liter/min)
Cycles per gallon (liter)	: 20 (6)
Air motor effective diameter	: 4-1/4 in. (108 mm)
Pump stroke	: 4 in. (100 mm)
Air consumption	: Approx. 13 CFM per gallon (6 m <sup>3</sup> /hr/liter) of fluid at 100 psi (7 bar)
Wetted parts	: Steel, Aluminum, Brass, Leather, Buna-N

## THE GRACO WARRANTY AND DISCLAIMERS

### WARRANTY

Graco warrants all equipment manufactured by it and bearing its name to be free from defects in material and workmanship on the date of sale by an authorized Graco distributor to the original purchaser for use. As purchaser's sole remedy for breach of this warranty, Graco will, for a period of twelve months from the date of sale, repair or replace any part of the equipment proven defective. This warranty applies only when the equipment is installed, operated and maintained in accordance with Graco's written recommendations.

This warranty does not cover, and Graco shall not be liable for, any malfunction, damage or wear caused by faulty installation, misapplication, abrasion, corrosion, inadequate or improper maintenance, negligence, accident, tampering, or substitution of non-Graco component parts. Nor shall Graco be liable for malfunction, damage or wear caused by the incompatibility with Graco equipment of structures, accessories, equipment or materials not supplied by Graco, or the improper design, manufacture, installation, operation or maintenance of structures, accessories, equipment or materials not supplied by Graco.

This warranty is conditioned upon the prepaid return of the equipment claimed to be defective for examination by Graco to verify the claimed defect. If the claimed defect is verified, Graco will repair or replace free of charge any defective parts. The equipment will be returned to the original purchaser transportation prepaid. If inspection of the equipment does not disclose any defect in material or workmanship, repairs will be made at a reasonable charge, which charges may include the the costs of parts, labor and transportation.

### DISCLAIMERS AND LIMITATIONS

THE TERMS OF THIS WARRANTY CONSTITUTE PURCHASER'S SOLE AND EXCLUSIVE REMEDY AND ARE IN LIEU OF ANY OTHER WARRANTIES (EXPRESS OR IMPLIED), INCLUDING WARRANTY OF MERCHANTABILITY OR WARRANTY OF FITNESS FOR A PARTICULAR PURPOSE, AND OF ANY NON-CONTRACTUAL LIABILITIES, INCLUDING PRODUCT LIABILITIES, BASED ON NEGLIGENCE OR STRICT LIABILITY. EVERY FORM OF LIABILITY FOR DIRECT, SPECIAL OR CONSEQUENTIAL DAMAGES OR LOSS IS EXPRESSLY EXCLUDED AND DENIED. IN NO CASE SHALL GRACO'S LIABILITY EXCEED THE AMOUNT OF THE PURCHASE PRICE. ANY ACTION FOR BREACH OF WARRANTY MUST BE BROUGHT WITHIN TWO (2) YEARS OF THE DATE OF SALE.

### EQUIPMENT NOT COVERED BY GRACO WARRANTY

GRACO MAKES NO WARRANTY, AND DISCLAIMS ALL IMPLIED WARRANTIES OF MERCHANTABILITY AND FITNESS FOR A PARTICULAR PURPOSE, WITH RESPECT TO ACCESSORIES, EQUIPMENT, MATERIALS, OR COMPONENTS SOLD BUT NOT MANUFACTURED BY GRACO. These items sold, but not manufactured by Graco (such as electric motor, switches, hose, etc.), are subject to the warranty, if any, of their manufacturer. Graco will provide purchaser with reasonable assistance in making any claim for breach of these warranties.

Factory Branches: Atlanta, Chicago, Dallas, Detroit, Los Angeles, West Caldwell (N.J.)  
Subsidiary and Affiliate Companies: Canada; England; Switzerland; France; Germany; Hong Kong; Japan

GRACO INC. P.O. BOX 1441 MINNEAPOLIS, MN 55440-1441

PRINTED IN U.S.A. 306-726 9-61 Revised 3-89

18